

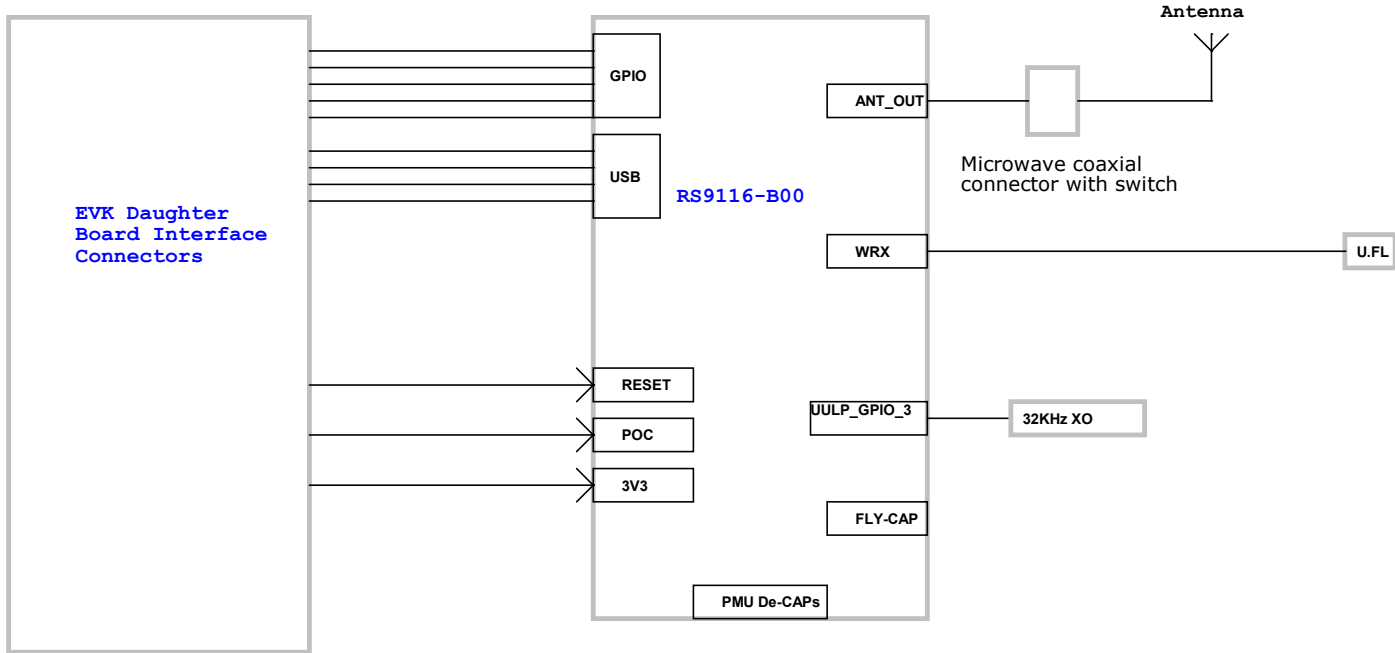

# RS9116-B00 EVK Daughter Board Block Diagram



Silicon Labs Confidential

 400 W Cesar Chavez Austin, TX 78701	
Size	Title
	<b>RS9116X-SB-EVK2-Daughter Board</b>
Part Number	Document Number
<Part Number>	<b>Block Diagram</b>
Date:	Thursday, September 24, 2020
Sheet	1 of 4
Rev	1.5

Note:: Please Follow the Fractus Antenna Guide Lines for Layout

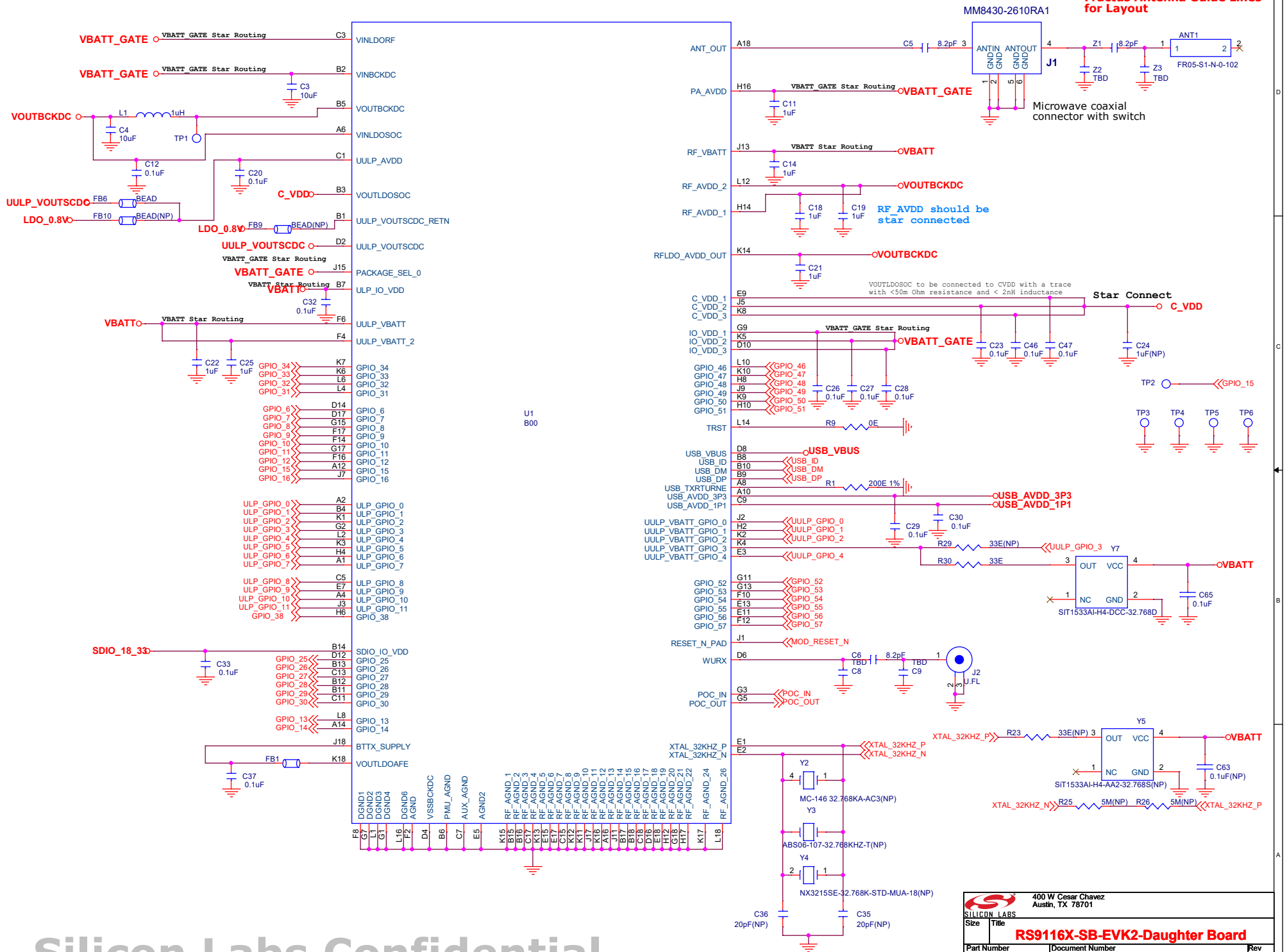

Silicon Labs Confidential

		400 W Cesar Chavez Austin, TX 78701	
Size	Title	<b>RS9116X-SB-EVK2-Daughter Board</b>	
Part Number	Document Number	<b>RS9116-B00</b>	
<Part Number>		Rev	1.5
Date:	Thursday, September 24, 2020	Sheet	2 of 4

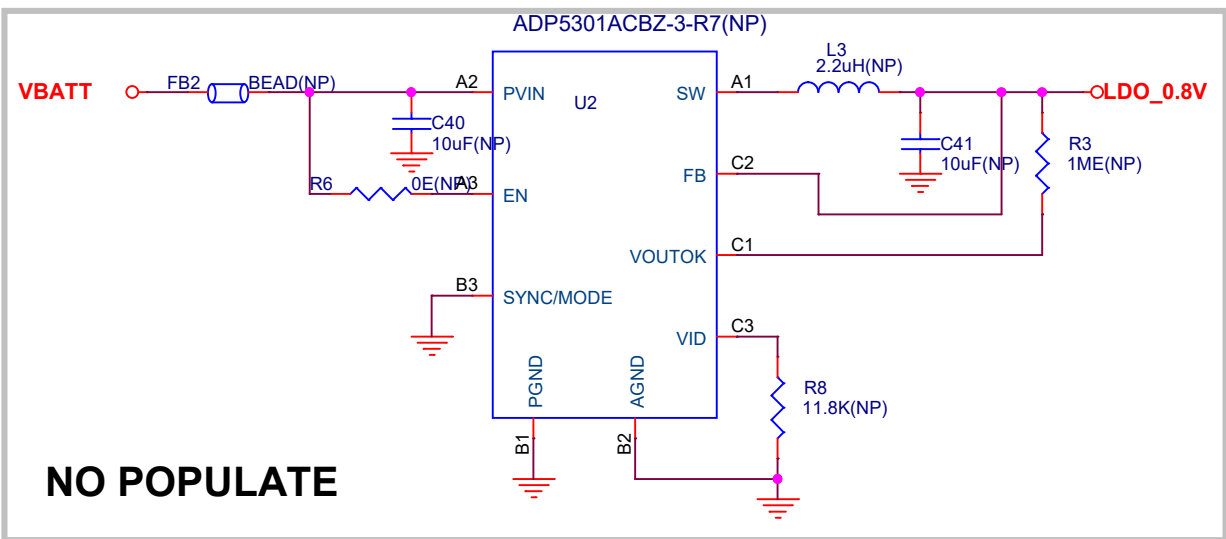
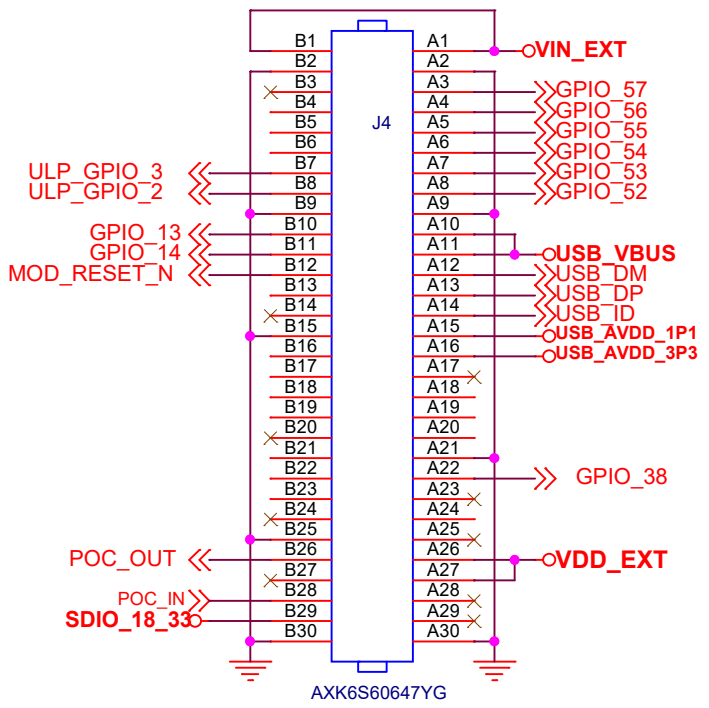
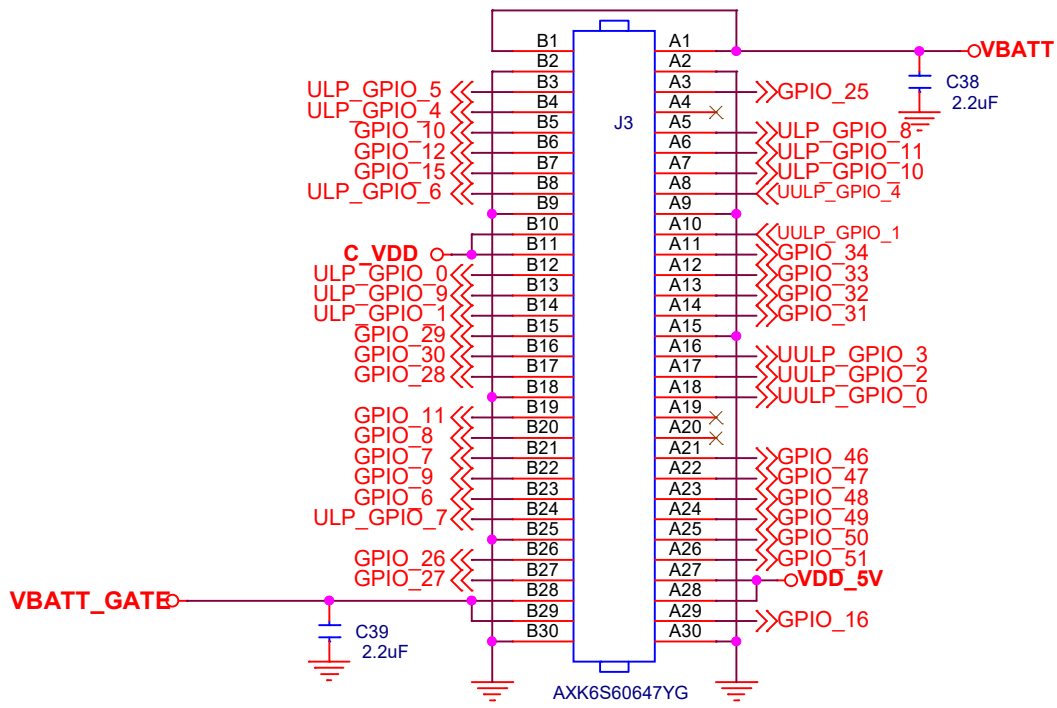

**Silicon Labs Confidential**

		400 W Cesar Chavez Austin, TX 78701	
Size	Title		
	<b>RS9116X-SB-EVK2-Daughter Board</b>		
Part Number	Document Number		Rev
<Part Number>	<b>Connector</b>		1.5
Date:	Thursday, September 24, 2020	Sheet	3 of 4

## Revision 1.0

- 1) Initial Version

## Revision 1.1

- 1) TRST change as per B00 -Module Rev2.0
- 2) Interfacing Headers(J3&J4) updated as per BaseBoard Rev1.3
- 3) Added 32KHz Oscillator/Xtal options

## Revision 1.5

- 1) Added 32KHz Oscillator for UULP\_GPIO\_3
- 2) Title block changed from Redpine to Silabs on 24th September 2020

**Silicon Labs Confidential**

		400 W Cesar Chavez Austin, TX 78701	
SILICON LABS			
Size	Title		
	<b>RS9116X-SB-EVK2-Daughter Board</b>		
Part Number	Document Number	Rev	
<Part Number>	<b>Revision History</b>	1.5	
Date:	Thursday, September 24, 2020	Sheet	4 of 4