

ZGM130S Z-Wave Long Range Radio Board BRD4207A Reference Manual



The BRD4207A Wireless Gecko Radio Board enables developers to develop Silicon Labs Z-Wave® Long Range applications. The board contains a Wireless Gecko System-in-Package module and it is optimized for operating at 14 dBm output power. With the on-board SMA connector, conducted testing is supported, and it also enables attachment of external whip antenna for radiated tests.

This document contains a brief introduction and description of the BRD4207A Radio Board features, focusing on the RF section and performance.

RADIO BOARD FEATURES

- Wireless SiP: ZGM130S037HGN2
 - CPU core: ARM Cortex®-M4 with FPU
 - Flash memory: 512 kB
 - RAM: 64 kB
- Operation frequency: 863-876 MHz and 902-930 MHz
- Transmit power: 14 dBm
- Single SMA connector both for transmit and receive
- Optional printed antenna

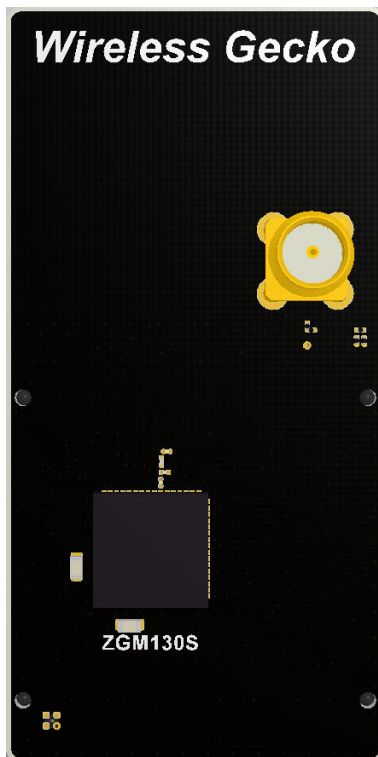

Table of Contents

1. Introduction	4
2. Radio Board Connector	5
2.1 Introduction	5
2.2 Radio Board Connector Pin Associations	5
3. Radio Board Block Summary	6
3.1 Introduction	6
3.2 Radio Board Block Diagram	6
3.3 Radio Board Block Description	6
3.3.1 SMA Connector	6
3.3.2 Printed Antenna	6
3.3.3 Radio Board Connectors	6
3.3.4 RGB LED	7
3.3.5 Serial EEPROM	7
4. RF Section	8
4.1 Introduction	8
4.2 Schematic of the RF Section	8
4.3 Bill of Materials for the Low-Pass Filter	8
4.4 Printed Antenna	9
5. Mechanical Details	10
6. EMC Compliance	11
6.1 Introduction	11
6.2 EMC Regulation Emission Limits	11
6.2.1 ETSI EN 300-200-1 Emission Limits for the 868-868.6 MHz Band	11
6.2.2 FCC15.247 Emission Limits for the 902-928 MHz Band	11
7. RF Performance	12
7.1 Conducted Power Measurements	12
7.1.1 Conducted Power Measurements	12
7.1.2 Conducted Power Measurements with Modulated Carrier	14
7.2 Radiated Power Measurements	15
7.2.1 Radiated Measurements	16
7.2.2 Antenna Pattern Measurements	18
8. EMC Compliance Recommendations	19
8.1 Recommendations for 868 MHz ETSI EN 300-220-1 compliance	19
8.2 Recommendations for 908 MHz and 921 MHz FCC 15.247 compliance	19
9. Board Revision History	20
10. Errata	21

11. Document Revision History 22

1. Introduction

The EFR32 Wireless Gecko Radio Boards provide a development platform (together with the Wireless Starter Kit Mainboard) for the Silicon Labs EFR32 Wireless Gecko System-in-Package modules and serve as reference designs for the matching networks of the RF interfaces.

The BRD4207A Wireless Gecko Radio Board plugs into the Wireless Starter Kit Mainboard, which is included with the Wireless Gecko Starter Kit and gives access to display, buttons, and additional features from Expansion Boards. With the supporting Simplicity Studio suite of tools, developers can take advantage of graphical wireless application development for Z-Wave Long Range applications and visual energy profiling and optimization. The board also serves as an RF reference design for applications targeting wireless operation in the 863-876 MHz and 902-930 MHz bands with 14 dBm output power.

To develop and/or evaluate the ZGM130S, the BRD4207A Radio Board can be connected to the Wireless Starter Kit Mainboard to get access to display, buttons, and additional features from Expansion Boards, and also to evaluate the performance of the RF interfaces.

2. Radio Board Connector

2.1 Introduction

The board-to-board connector scheme allows access to all ZGM130S GPIO pins as well as the RESETn signal. For more information on the functions of the available pins, see the [ZGM130S data sheet](#).

2.2 Radio Board Connector Pin Associations

The figure below shows the mapping between the connector and the ZGM130S pins and their function on the Wireless Starter Kit Main-board.

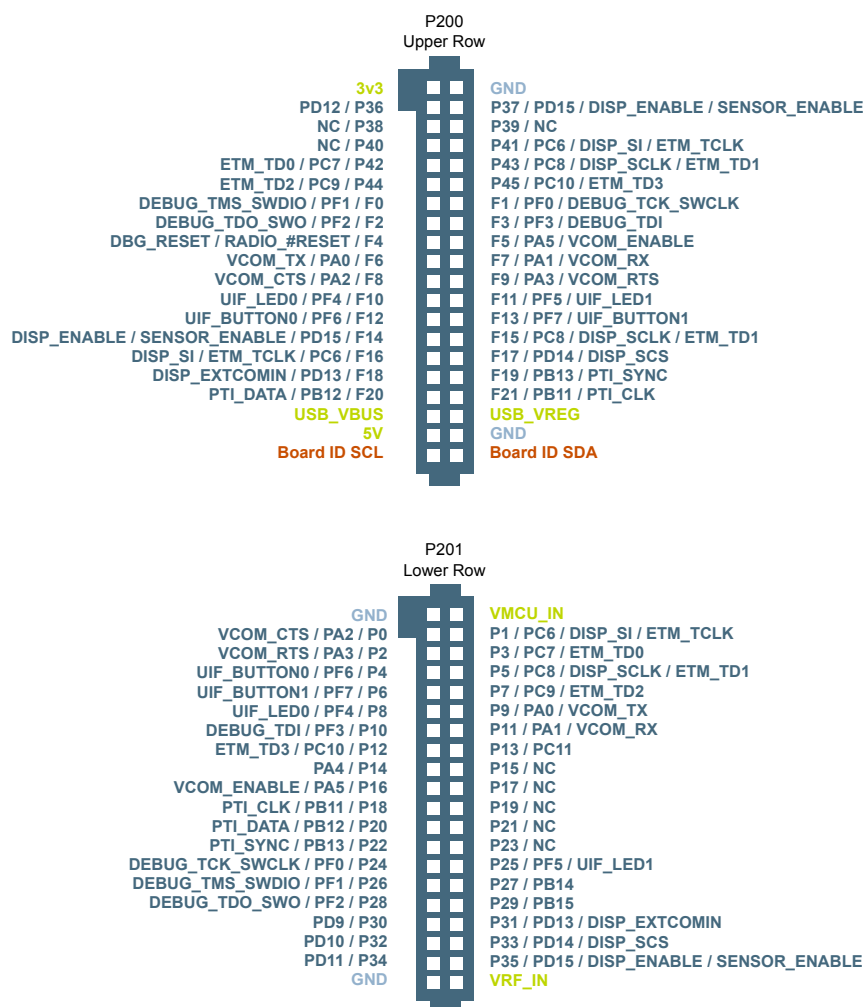

Figure 2.1. BRD4207A Radio Board Connector Pin Mapping

3. Radio Board Block Summary

3.1 Introduction

This section introduces the blocks of the BRD4207A Radio Board.

3.2 Radio Board Block Diagram

The block diagram of the BRD4207A Radio Board is shown in the figure below.

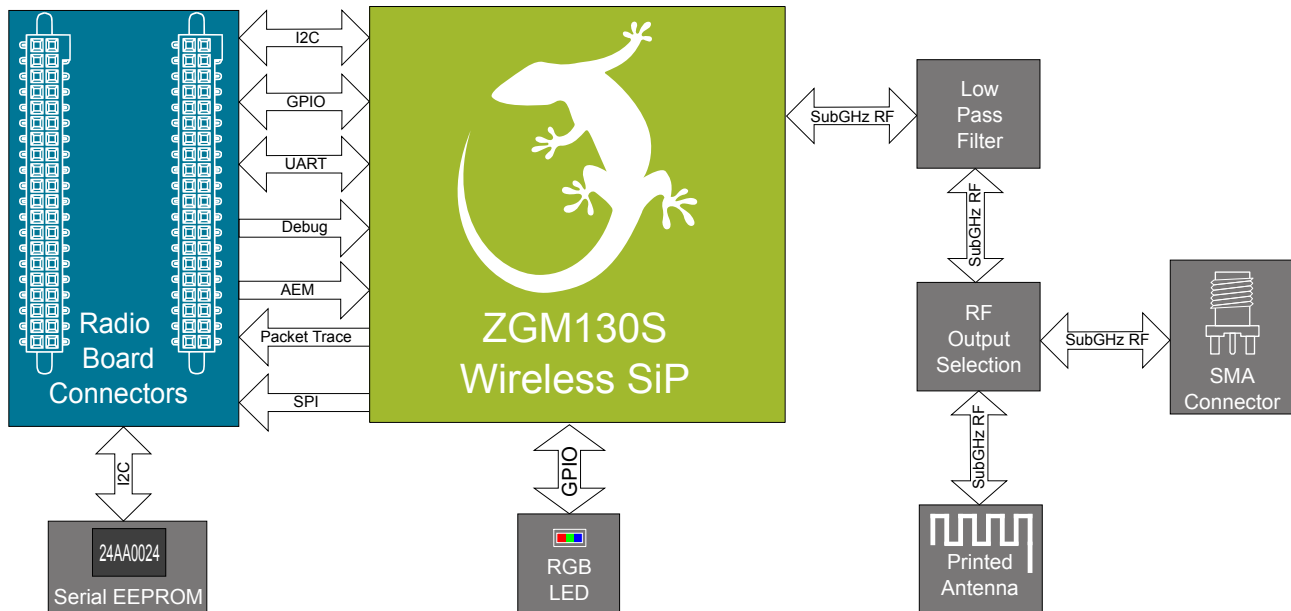

Figure 3.1. BRD4207A Block Diagram

3.3 Radio Board Block Description

3.3.1 SMA Connector

To be able to perform conducted measurements or mount external antenna for radiated measurements, range tests, etc., Silicon Labs added an SMA connector to the radio board. The connector allows an external 50 Ohm cable or antenna to be connected during design verification or testing.

3.3.2 Printed Antenna

The BRD4207A Radio Board includes a printed antenna tuned to have close to 50 Ohm impedance at the 863-930 MHz band.

For a detailed description of the antenna, see section [4.4 Printed Antenna](#).

3.3.3 Radio Board Connectors

Two dual-row, 0.05" pitch polarized connectors make up the BRD4207A Radio Board interface to the Wireless Starter Kit Mainboard.

For more information on the pin mapping between the ZGM130S037HGN2 and the connectors, refer to section [2.2 Radio Board Connector Pin Associations](#).

3.3.4 RGB LED

The radio board features an RGB LED that is controlled by GPIO pins on the ZGM130S. The LED is connected in an active-low configuration.

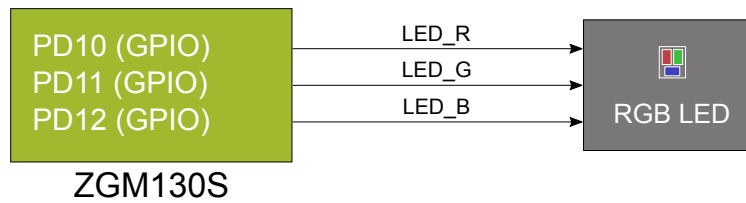

Figure 3.2. RGB LED

3.3.5 Serial EEPROM

The BRD4207A Radio Board is equipped with a serial I²C EEPROM for board identification and to store additional board-related information.

4. RF Section

4.1 Introduction

This section gives a short introduction to the RF section of the BRD4207A Radio Board.

4.2 Schematic of the RF Section

The schematic of the RF section of the BRD4207A Radio Board is shown in the following figure.

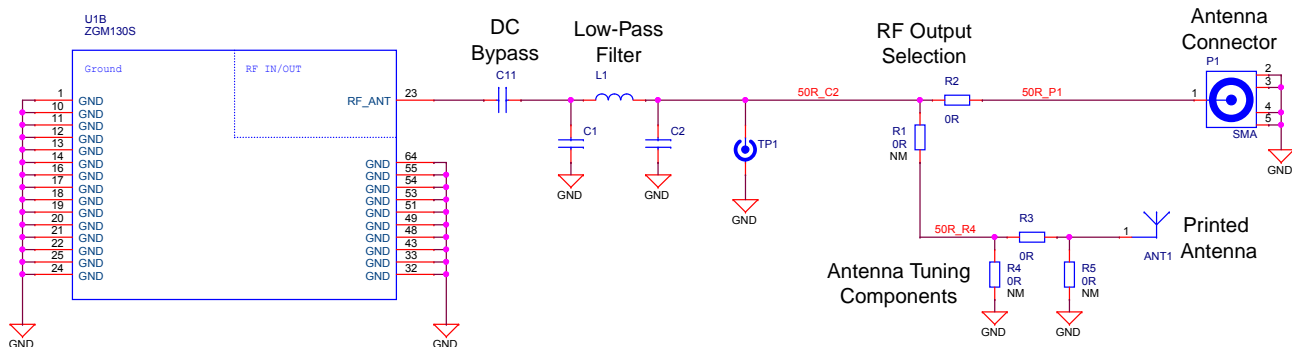

Figure 4.1. Schematic of the RF Section of the BRD4207A

The ZGM130S module has an internal balun and matching network, but to ensure safe margins on harmonics in case of transmission with 14 dBm output power, an external low-pass filter section has been added to the output of the module.

4.3 Bill of Materials for the Low-Pass Filter

The Bill of Materials of the low-pass filter and the DC bypass of the BRD4207A Radio Board is shown in the following table.

Table 4.1. Bill of Materials for the BRD4207A Low-Pass Filter and DC Bypass

Component Name	Value	Manufacturer	Part Number
L1	8.2 nH	Murata	LQP03TN8N2H02D
C1	3.0 pF	Murata	GRM0335C1H3R0BA01D
C2	3.0 pF	Murata	GRM0335C1H3R0BA01D
C11	56 pF	Murata	GRM0335C1H560JA01D

4.4 Printed Antenna

The BRD4207A Radio Board includes a printed antenna tuned to have close to 50 Ohm impedance at the 863-930 MHz band, while the radio board is plugged into the WSTK. The antenna is not connected to the RF output by default; the RF output selector 0 Ohm resistor should be repositioned from the R2 to the R1 position in order to enable operation with the printed antenna.

The impedance and reflection of the printed antenna is shown in the following figures.

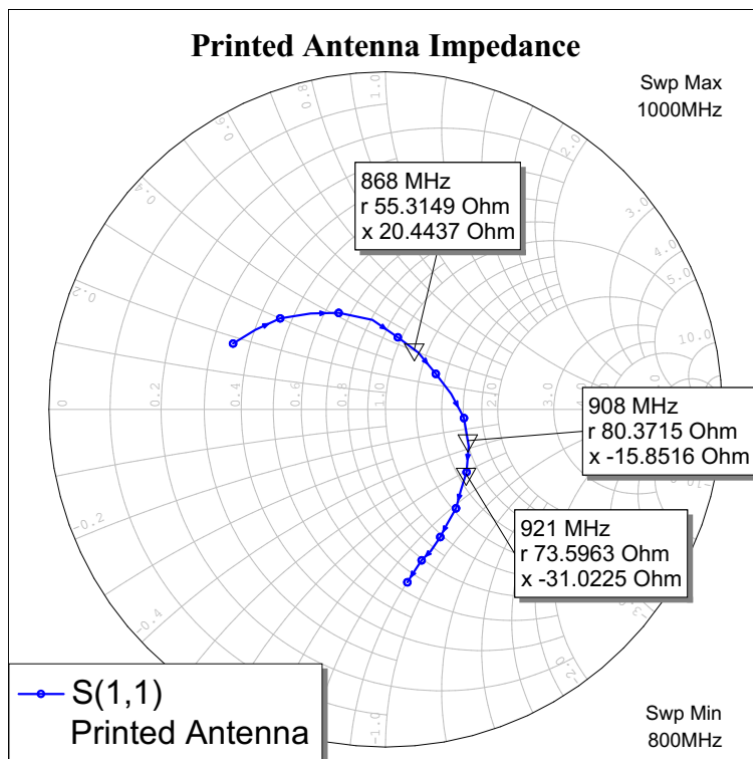

Figure 4.2. Impedance of the Printed Antenna of the BRD4207A

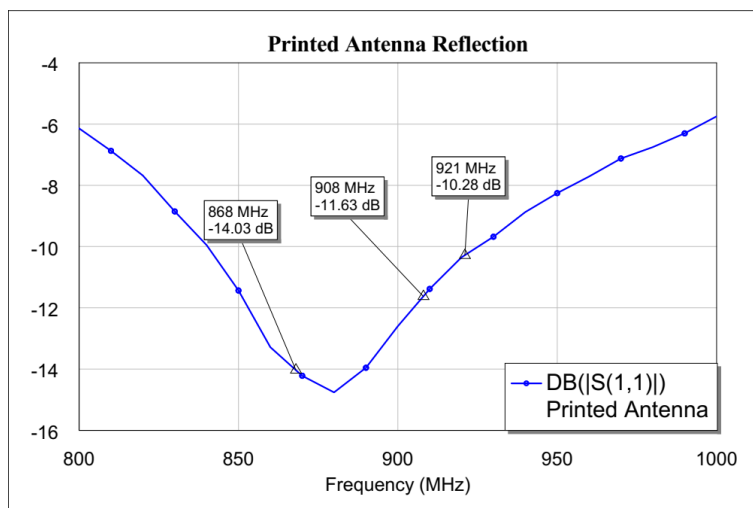

Figure 4.3. Reflection of the Printed Antenna of the BRD4207A

As it can be observed, the impedance is close to 50 Ohm at all of the marked frequencies. The reflection is better than -10 dB.

5. Mechanical Details

The BRD4207A Radio Board is illustrated in the figures below.

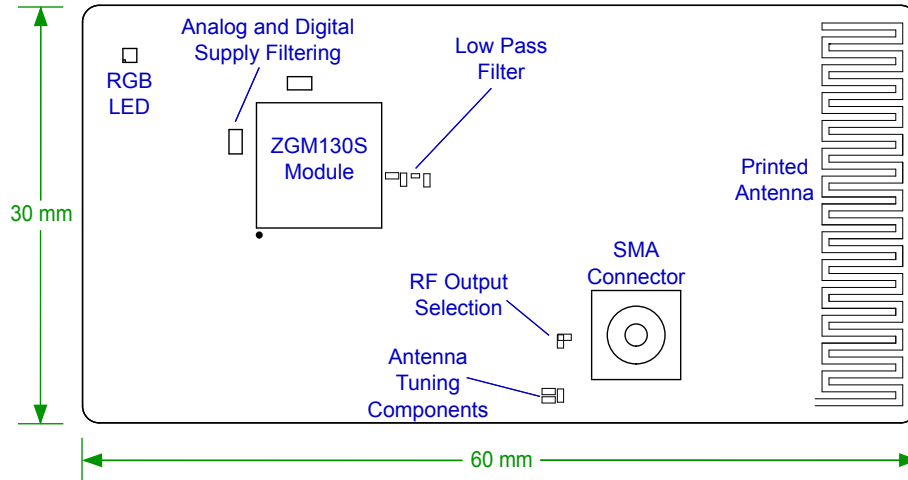

Figure 5.1. BRD4207A Top View

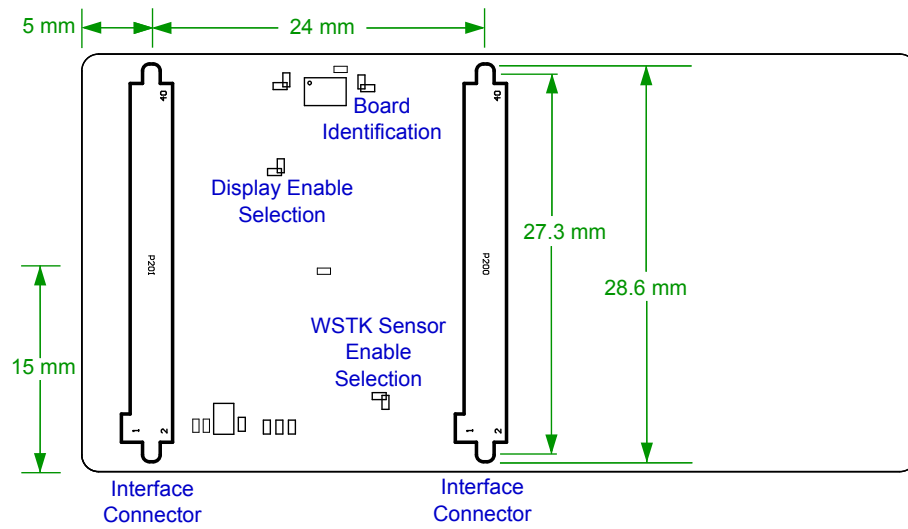

Figure 5.2. BRD4207A Bottom View

6. EMC Compliance

6.1 Introduction

Compliance of the fundamental and harmonic levels of the BRD4207A Radio Board is tested against the following standards:

- 868 MHz:
 - ETSI EN 300-220-1
- 908 MHz:
 - FCC 15.247
- 921 MHz:
 - FCC 15.247

6.2 EMC Regulation Emission Limits

6.2.1 ETSI EN 300-200-1 Emission Limits for the 868-868.6 MHz Band

Based on ETSI EN 300-220-1, the allowed maximum fundamental power for the 868-868.6 MHz band is 25 mW (14 dBm) e.r.p. both for conducted and radiated measurements.

Note: Further in this document EIRP (Effective Isotropic Radiated Power) will be used instead of e.r.p. (Effective Radiated Power) for the comparison of the radiated limits and measurement results. The 25 mW e.r.p radiated limit is equivalent to 16.1 dBm EIRP.

For the unwanted emission limits see the table below.

Table 6.1. ETSI EN 300-220-1 Spurious Domain Emission Limits in e.r.p. (and EIRP)

Frequency	47 MHz to 74 MHz 87.5 MHz to 118 MHz 174 MHz to 230 MHz 470 MHz to 862 MHz	Other frequencies below 1000 MHz	Frequencies above 1000 MHz
Operating	4 nW (-54 dBm e.r.p. = -51.8 dBm EIRP)	250 nW (-36 dBm e.r.p. = -33.9 dBm EIRP)	1 uW (-30 dBm e.r.p. = -27.9 dBm EIRP)
Standby	2 nW (-57 dBm e.r.p. = -54.8 dBm EIRP)	2 nW (-57 dBm e.r.p. = -54.8 dBm EIRP)	20 nW (-47 dBm e.r.p. = -44.8 dBm EIRP)

The above ETSI limits are also applied both for conducted and radiated measurements.

6.2.2 FCC15.247 Emission Limits for the 902-928 MHz Band

FCC 15.247 allows conducted output power up to 1 Watt (30 dBm) in the 902-928 MHz band. For spurious emissions the limit is -20 dBc based on either conducted or radiated measurement, if the emission is not in a restricted band. The restricted bands are specified in FCC 15.205. In these bands the spurious emission levels must meet the levels set out in FCC 15.209. In the range from 960 MHz to the frequency of the 10th harmonic it is defined as 0.5 mV/m at 3 m distance (equals to -41.2 dBm in EIRP).

In case of operating in the 902-928 MHz band, from the first 10 harmonics only the 2nd and 7th harmonics are not in restricted bands. The 6th is also not in a restricted band, but only if the carrier frequency is above 910 MHz. For these the -20 dBc limit should be applied. For the harmonics, that are in a restricted band, the -41.2 dBm limit should be applied.

7. RF Performance

7.1 Conducted Power Measurements

During measurements, the BRD4207A Radio Board was attached to a Wireless Starter Kit Mainboard which was supplied by USB. The voltage supply for the radio board was 3.3 V.

7.1.1 Conducted Power Measurements

The BRD4207A Radio Board was connected directly to a Spectrum Analyzer through its SMA connector. The supply for the module (VDD) was 3.3 V provided by the mainboard; for details, see the schematic of the BRD4207A. The transceiver was operated in continuous carrier transmission mode. The output power of the radio was set to 14 dBm.

The typical output spectrums are shown in the following figures.

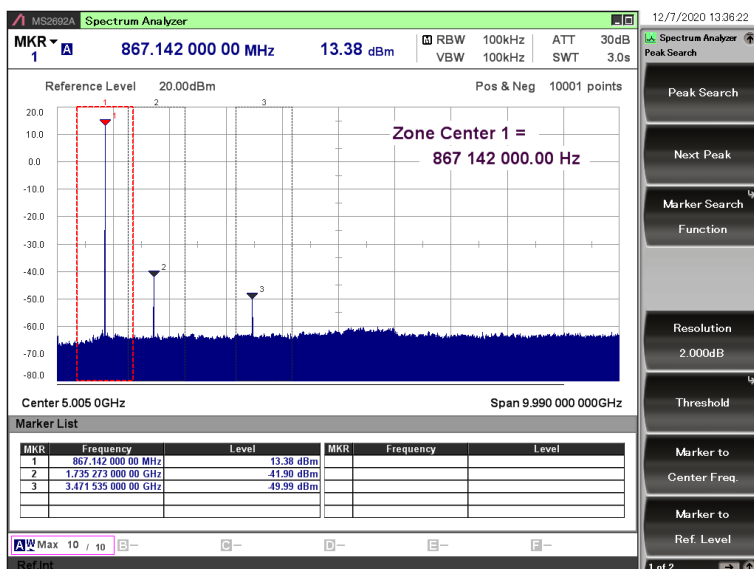

Figure 7.1. Typical Output Spectrum of the BRD4207A in the 868 MHz band

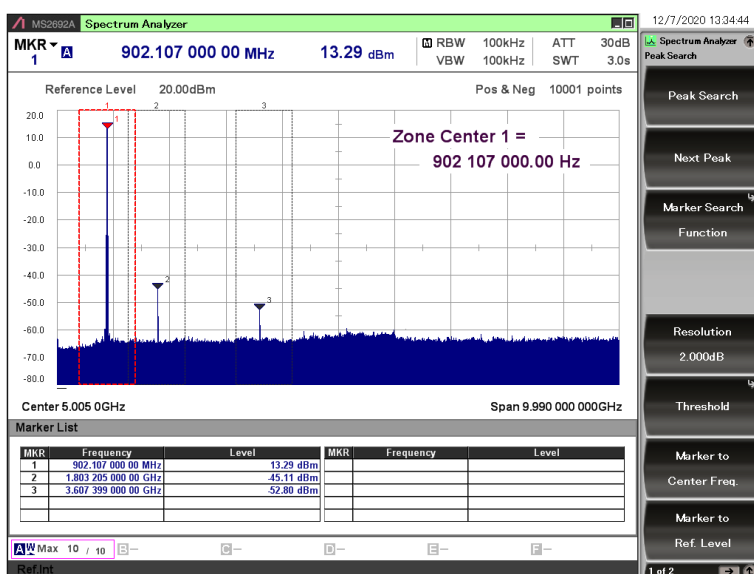

Figure 7.2. Typical Output Spectrum of the BRD4207A in the 908 MHz band

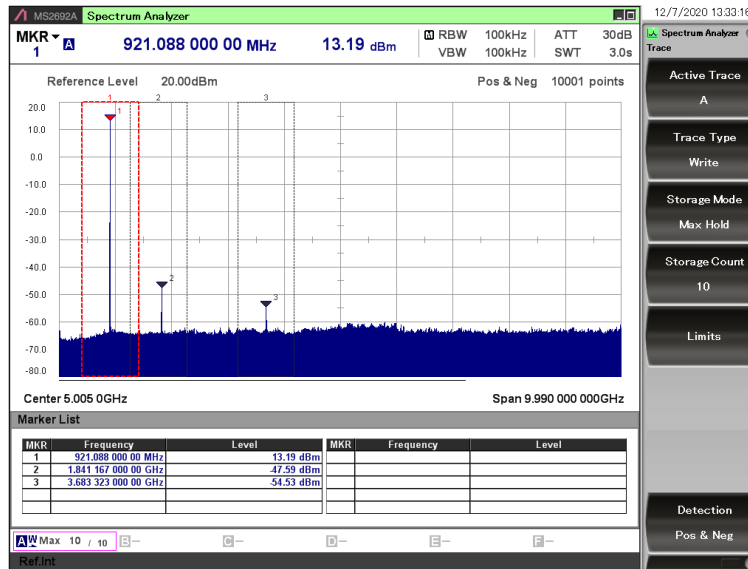

Figure 7.3. Typical Output Spectrum of the BRD4207A in the 921 MHz band

As shown in the figures, the fundamental is a bit lower than 14 dBm due to the insertion loss of the low pass filter. So, it is under the ETSI and FCC limits in all bands. The unwanted emissions are also under their corresponding limit, so the conducted spectrums are compliant with the regulation limits.

7.1.2 Conducted Power Measurements with Modulated Carrier

Depending on the applied modulation scheme, and the spectrum analyzer settings specified by the relevant EMC regulations, the measured power levels are usually lower compared to the results with unmodulated carrier. These differences will be measured and used as relaxation factors on the results of the radiated measurement performed with unmodulated carrier. This way, the radiated compliance with modulated transmission can be evaluated.

In this case, both the ETSI EN 300-220-1 and the FCC 15.247 regulations define the following spectrum analyzer settings for measuring the unwanted emissions above 1 GHz:

- Detector: Average
- RBW: 1 MHz

The table below shows the measured differences for the Z-Wave Long Range modulation scheme. These values will be used as relaxation factors for the radiated measurements.

Table 7.1. Measured Relaxation Factors

Harmonic	Z-Wave Long Range
2nd harmonic	-2.0
3rd harmonic	-4.5
4th harmonic	-7.9
5th harmonic	-9.1
6th harmonic	-11.5
7th harmonic	NA
8th harmonic	NA
9th harmonic	NA
10th harmonic	NA

Note: Above the 6th harmonic the conducted power levels were under the spectrum analyzer noise floor, so it was not possible to measure the relaxation.

7.2 Radiated Power Measurements

During measurements, the BRD4207A Radio Board was attached to a Wireless Starter Kit Mainboard which was supplied by USB. The voltage supply for the radio board was 3.3 V. The radiated power was measured in an antenna chamber by rotating the board 360 degrees with horizontal and vertical reference antenna polarizations in the XY, XZ, and YZ cuts. The measurement planes are illustrated in the figure below.

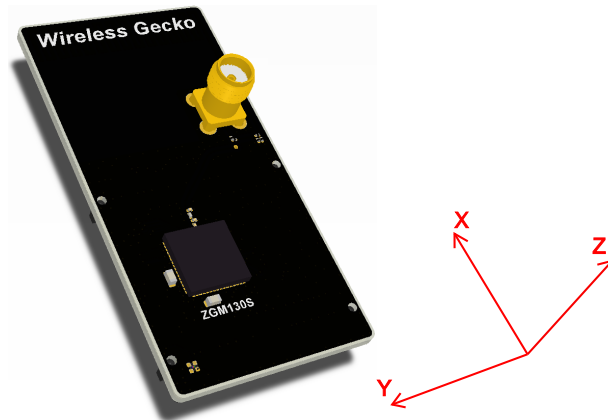

Figure 7.4. Illustration of Reference Planes with a Radio Board

Note: The radiated measurement results presented in this document were recorded in an unlicensed antenna chamber. Also, the radiated power levels may change depending on the actual application (PCB size, used antenna, and so on). Therefore, the absolute levels and margins of the final application are recommended to be verified in a licensed EMC testhouse.

7.2.1 Radiated Measurements

For the radiated power measurements, an external whip antenna (P/N: ANT-SS900) was used as a transmitter antenna. It was connected to the SMA connector of the BRD4207A Radio Board. The supply for the module (VDD) was 3.3 V provided by the mainboard; for details, see the schematic of the BRD4207A. The transceiver was operated in continuous carrier transmission mode. The output power of the radio was set to 14 dBm.

The measured radiated powers are shown in the table below. The correction factors are applied based on the Z-Wave Long Range modulation scheme, showed in section 7.1.2 [Conducted Power Measurements with Modulated Carrier](#).

Table 7.2. Maximums of the Measured Radiated Powers in EIRP [dBm] and the Calculated Modulated Margins in [dB]

Frequency (868.4 MHz)	Measured Un-modulated EIRP [dBm]	Orientation	Z-Wave Long Range Transmission			Limit in EIRP [dBm]
			Correction Factor [dB]	Calculated Modulated EIRP [dBm]	Modulated Margin [dB]	
Fund	11.4	XZ/H	NA (0 is used)	11.4	4.7	16.1
2nd	-44.0	XZ/H	-2.0	-46.0	18.1	-27.9
3rd	-61.6	XZ/H	-4.5	-66.1	38.2	-27.9
4th	-50.4	YZ/V	-7.9	-58.3	30.4	-27.9
5th	-55.3	YZ/H	-9.1	-64.4	36.5	-27.9
6th	-54.8	XZ/H	-11.5	-66.3	38.4	-27.9
7th	-56.3	XZ/H	NA (0 is used)	-56.3	28.4	-27.9
8th	Noise*	-/-	NA (0 is used)	-	>20	-27.9
9th	-51.1	YZ/H	NA (0 is used)	-51.1	23.2	-27.9
10th	Noise*	-/-	NA (0 is used)	-	>20	-27.9

* Signal level is below the Spectrum Analyzer noise floor.

Table 7.3. Maximums of the Measured Radiated Powers in EIRP [dBm] and the Calculated Modulated Margins in [dB]

Frequency (908.4 MHz)	Measured Un-modulated EIRP [dBm]	Orientation	Z-Wave Long Range Transmission			Limit in EIRP [dBm]
			Correction Factor [dB]	Calculated Modulated EIRP [dBm]	Modulated Margin [dB]	
Fund	11.7	XY/H	NA (0 is used)	11.7	18.3	30.0
2nd	-47.0	XZ/H	-2.0	-49.0	>20	-20 dBc
3rd	-63.5	XY/H	-4.5	-68.0	26.8	-41.2
4th	-46.1	YZ/V	-7.9	-54.0	12.7	-41.2
5th	-48.7	XY/V	-9.1	-57.8	16.6	-41.2
6th	-49.8	XZ/H	-11.5	-61.3	20.1	-41.2
7th	-58.4	YZ/V	NA (0 is used)	-58.4	>20	-20 dBc
8th	-53.3	XZ/H	NA (0 is used)	-53.3	12.1	-41.2
9th	-56.2	YZ/H	NA (0 is used)	-56.2	15.0	-41.2
10th	Noise*	-/-	NA (0 is used)	-	>20	-41.2

* Signal level is below the Spectrum Analyzer noise floor.

Table 7.4. Maximums of the Measured Radiated Powers in EIRP [dBm] and the Calculated Modulated Margins in [dB]

Frequency (921.4 MHz)	Measured Un- modulated EIRP [dBm]	Orientation	Z-Wave Long Range Transmission			Limit in EIRP [dBm]
			Correction Fac- tor [dB]	Calculated Modulated EIRP [dBm]	Modulated Mar- gin [dB]	
Fund	11.0	XY/H	NA (0 is used)	11.0	19.0	30.0
2nd	-48.3	XZ/H	-2.0	-50.3	>20	-20 dBc
3rd	-63.7	YZ/V	-4.5	-68.2	27.0	-41.2
4th	-44.6	YZ/V	-7.9	-52.5	11.3	-41.2
5th	-46.8	XY/V	-9.1	-55.9	14.7	-41.2
6th	-47.6	XZ/H	-11.5	-59.1	>20	-20 dBc
7th	-58.7	XZ/H	NA (0 is used)	-58.7	>20	-20 dBc
8th	-48.5	XZ/H	NA (0 is used)	-48.5	7.3	-41.2
9th	Noise*	-/-	NA (0 is used)	-	>20	-41.2
10th	Noise*	-/-	NA (0 is used)	-	>20	-41.2

* Signal level is below the Spectrum Analyzer noise floor.

As shown in the tables above, the fundamental is below the regulation limits in all bands. The harmonics are also compliant (even without relaxation).

7.2.2 Antenna Pattern Measurements

The measured normalized antenna patterns are shown in the following figures.

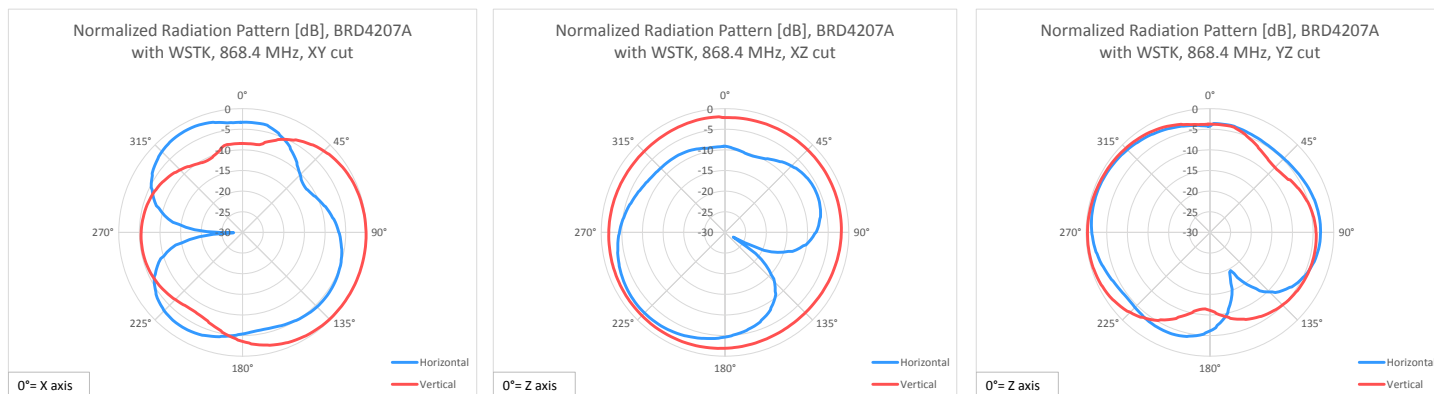

Figure 7.5. Normalized Antenna Pattern in the 868 MHz band

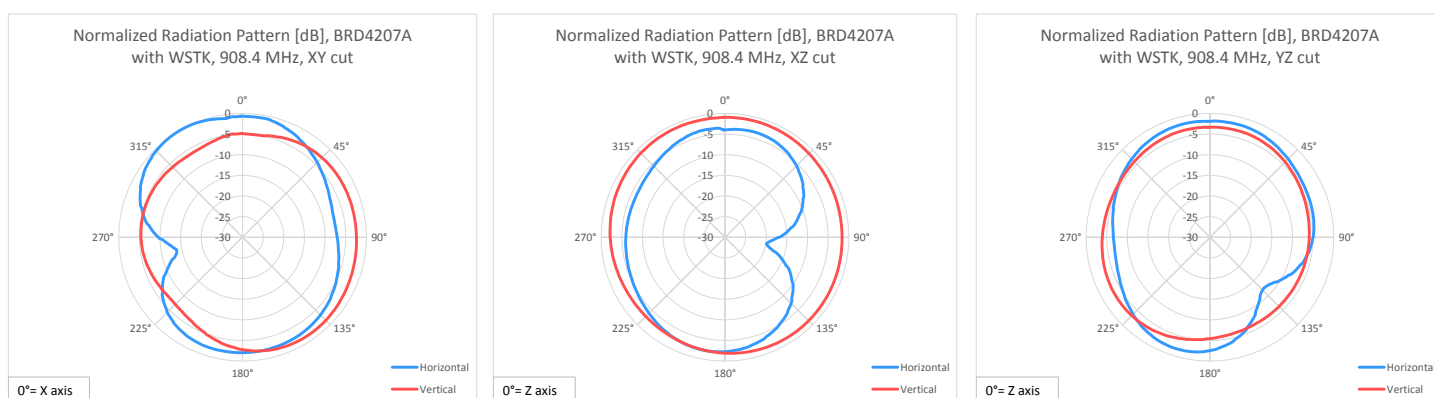

Figure 7.6. Normalized Antenna Pattern in the 908 MHz band

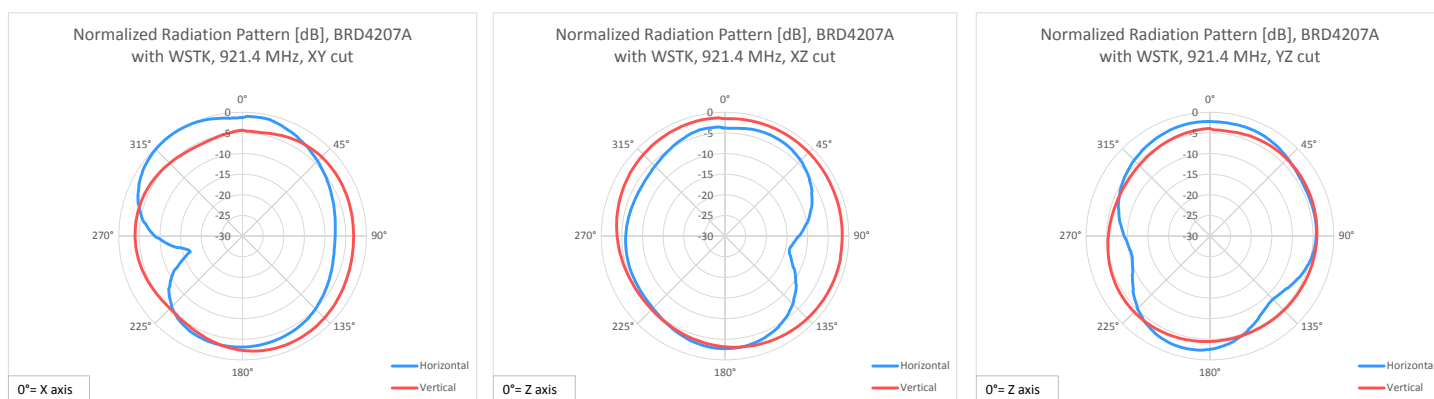

Figure 7.7. Normalized Antenna Pattern in the 921 MHz band

8. EMC Compliance Recommendations

8.1 Recommendations for 868 MHz ETSI EN 300-220-1 compliance

As it was shown in the previous chapter the BRD4207A Wireless Gecko Radio Board is compliant with the emission limits of the ETSI EN 300-220-1 regulation with 14 dBm output power.

8.2 Recommendations for 908 MHz and 921 MHz FCC 15.247 compliance

As it was shown in the previous chapter, the BRD4207A Wireless Gecko Radio Board is compliant with the emission limits of the FCC 15.247 regulation with 14 dBm output power.

9. Board Revision History

The board revision is laser engraved in the Board Info field on the bottom side of the PCB, as outlined in the figure below. The revision printed on the silkscreen is the PCB revision.

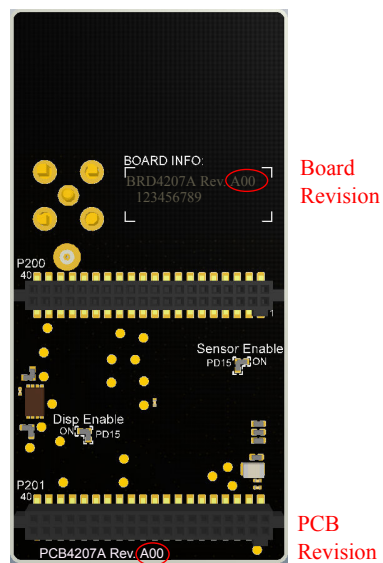

Figure 9.1. Revision Info

Table 9.1. BRD4207A Radio Board Revision History

Board Revision	Description
A00	Initial production release.

10. Errata

There are no known errata at present.

11. Document Revision History

Revision 1.0

Dec, 2020

- Initial document release.

Simplicity Studio

One-click access to MCU and wireless tools, documentation, software, source code libraries & more. Available for Windows, Mac and Linux!



IoT Portfolio

www.silabs.com/loT



SW/HW

www.silabs.com/simplicity



Quality

www.silabs.com/quality



Support & Community

www.silabs.com/community

Disclaimer

Silicon Labs intends to provide customers with the latest, accurate, and in-depth documentation of all peripherals and modules available for system and software implementers using or intending to use the Silicon Labs products. Characterization data, available modules and peripherals, memory sizes and memory addresses refer to each specific device, and "Typical" parameters provided can and do vary in different applications. Application examples described herein are for illustrative purposes only. Silicon Labs reserves the right to make changes without further notice to the product information, specifications, and descriptions herein, and does not give warranties as to the accuracy or completeness of the included information. Without prior notification, Silicon Labs may update product firmware during the manufacturing process for security or reliability reasons. Such changes will not alter the specifications or the performance of the product. Silicon Labs shall have no liability for the consequences of use of the information supplied in this document. This document does not imply or expressly grant any license to design or fabricate any integrated circuits. The products are not designed or authorized to be used within any FDA Class III devices, applications for which FDA premarket approval is required, or Life Support Systems without the specific written consent of Silicon Labs. A "Life Support System" is any product or system intended to support or sustain life and/or health, which, if it fails, can be reasonably expected to result in significant personal injury or death. Silicon Labs products are not designed or authorized for military applications. Silicon Labs products shall under no circumstances be used in weapons of mass destruction including (but not limited to) nuclear, biological or chemical weapons, or missiles capable of delivering such weapons. Silicon Labs disclaims all express and implied warranties and shall not be responsible or liable for any injuries or damages related to use of a Silicon Labs product in such unauthorized applications.

Trademark Information

Silicon Laboratories Inc.®, Silicon Laboratories®, Silicon Labs®, SiLabs® and the Silicon Labs logo®, Bluegiga®, Bluegiga Logo®, ClockBuilder®, CMEMS®, DSPLL®, EFM®, EFM32®, EFR, Ember®, Energy Micro, Energy Micro logo and combinations thereof, "the world's most energy friendly microcontrollers", Ember®, EZLink®, EZRadio®, EZRadioPRO®, Gecko®, Gecko OS, Gecko OS Studio, ISOModem®, Precision32®, ProSLIC®, Simplicity Studio®, SiPHY®, Telegesis, the Telegesis Logo®, USBXpress®, Zentri, the Zentri logo and Zentri DMS, Z-Wave®, and others are trademarks or registered trademarks of Silicon Labs. ARM, CORTEX, Cortex-M3 and THUMB are trademarks or registered trademarks of ARM Holdings. Keil is a registered trademark of ARM Limited. Wi-Fi is a registered trademark of the Wi-Fi Alliance. All other products or brand names mentioned herein are trademarks of their respective holders.



Silicon Laboratories Inc.
400 West Cesar Chavez
Austin, TX 78701
USA

<http://www.silabs.com>