

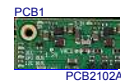

EFM32 Tiny Gecko 11 STK	
Board Function	Page
Title Page	1
User Interface	2
EFM32 Signal Assignments	3
EFM32 Power	4
EFM32 I/O	5
LCD	6
Advanced Energy Monitor	7
Debug Interface	8
Power & Misc	9
Board Controller MCU	10
Board Controller Misc	11

Revision History	
Rev.	Description
A03	Initial release.

LEGAL NOTICE:
 SILICON LABORATORIES INC. ("SILICON LABS") AND/OR ITS LICENSORS DO NOT WARRANT THE ACCURACY OR COMPLETENESS OF THIS SCHEMATIC OR ANY INFORMATION CONTAINED WITHIN THIS SCHEMATIC. IT IS PROVIDED "AS-IS" FOR REFERENCE ONLY. SILICON LABS DOES NOT WARRANT THAT THIS DESIGN WILL MEET THE SPECIFICATIONS, BE SUITABLE FOR YOUR APPLICATION OR FIT FOR ANY PARTICULAR PURPOSE, OR WILL OPERATE IN YOUR IMPLEMENTATION. SILICON LABS AND ITS LICENSORS DO NOT WARRANT THAT THE DESIGN IMPLIED IN THIS SCHEMATIC IS PRODUCTION-WORTHY. YOU SHOULD COMPLETELY VALIDATE AND TEST YOUR DESIGN IMPLEMENTATION TO CONFIRM SYSTEM FUNCTIONALITY FOR YOUR APPLICATION.



/
BRD2102A

		Schematic Title	
		EFM32 Tiny Gecko 11 Starter Kit	
Designed: HEL		Approved: JNO	
Page Title		Title Page	
Size: A3	BOM Doc No: <Cage Code>	Document number	Revision
Design Created Date: Tuesday, December 06, 2016		Sheet Created Date: Tuesday, December 06, 2016	Sheet Modified Date: Monday, May 22, 2017
		Document number	Revision
		BRD2102A	A03
		Sheet	Sheet
		1	of 11

User Pushbuttons

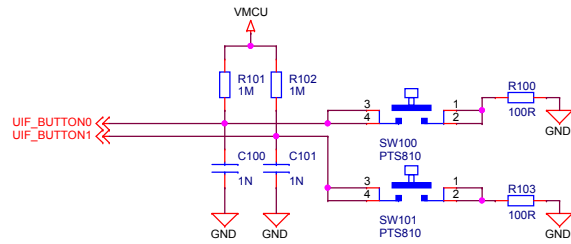

User LEDs

User LEDs

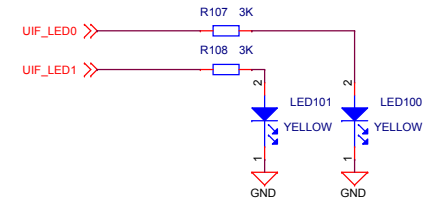

Touch Pads

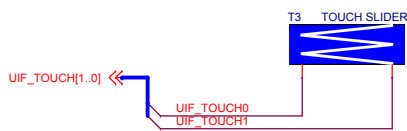

LESENSE LC-Sensor

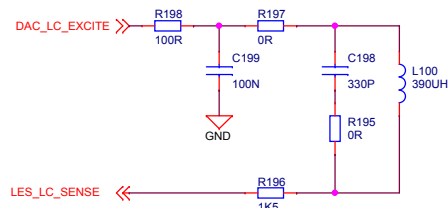

EXP Header

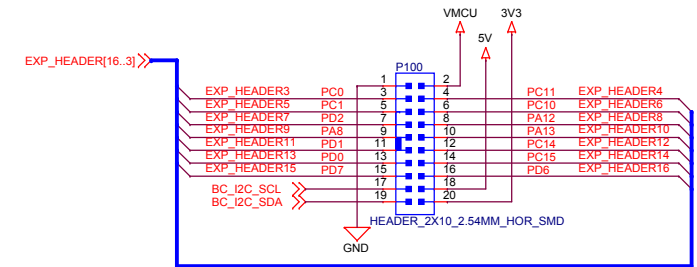

EXP-Header Functionality

1	GND		
3	PC0	CAN0_RX #0	PCNT0_S0IN #2
5	PC1	CAN0_TX #0	PCNT0_S1IN #2
7	PD2		
9	PA8		VDAC0_OUT1ALT #4
11	PD1		
13	PD0		
15	PD7	I2C0_SCL #1	
17		Reserved for EXP Board Identification	
19		Reserved for EXP Board Identification	

2	VMCU		
4	PC11	US0_TX #2	
6	PC10	US0_RX#2	
8	PA12	US0_CLK#5	
10	PA13	US0_CS#5	
12	PC14	LEU0_TX #2	
14	PC15	LEU0_RX #2	
16	PD6	I2C0_SDA #1	
18	5V		
20	3V3		

Relative Humidity & Temperature Sensor

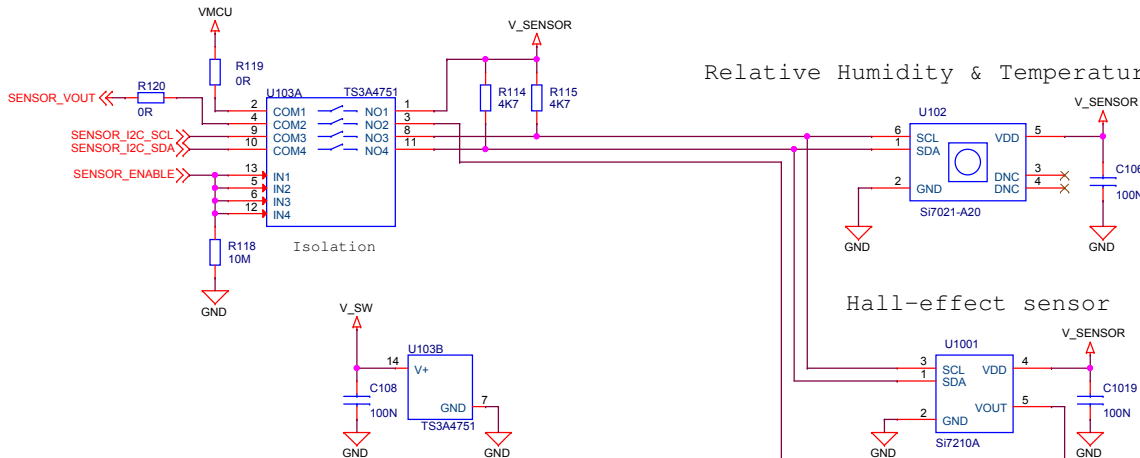

Hall-effect sensor

BRD2102A

		Schematic Title	
		EFM32 Tiny Gecko 11 Starter Kit	
Designed: HEL Approved: JNO		Page Title	
		User Interfaces	
Size A3	BOM Doc No: <Cage Code>	Document number BRD2102A	Revision A03
Design Created Date: Tuesday, December 06, 2016		Sheet Created Date Tuesday, December 06, 2016	Sheet Modified Date Monday, May 22, 2017
		Sheet 2	of 11

PA Connections

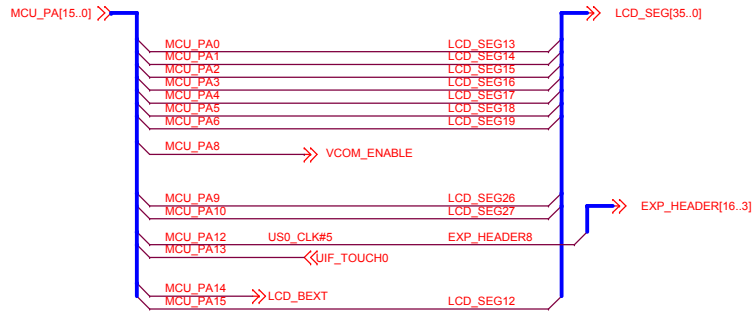

PB Connections

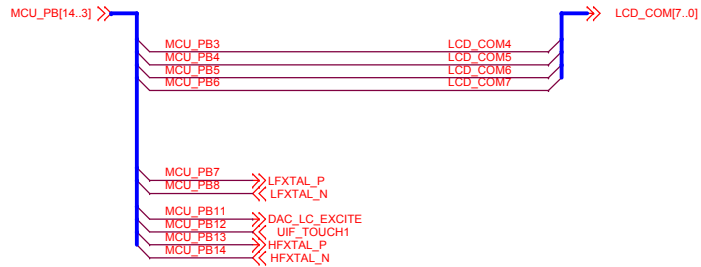

PC Connections

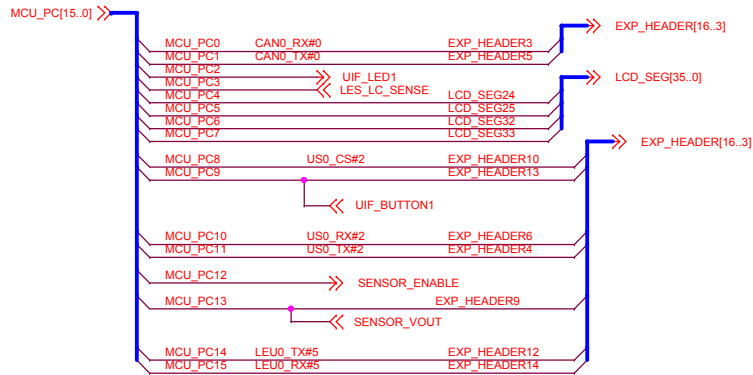

PD Connections

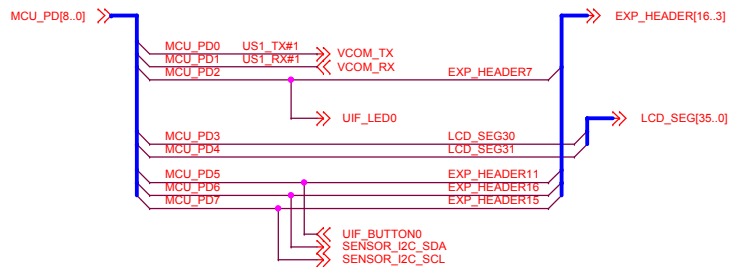

Breakout Connections

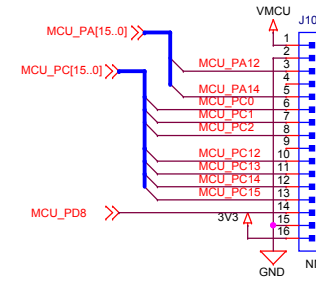

Breakout header labels:

- VMCU
- GND
- A12
- NC
- A14
- C0
- C1
- C2
- NC
- C12
- C13
- C14
- C15
- D8
- GND
- 3V3

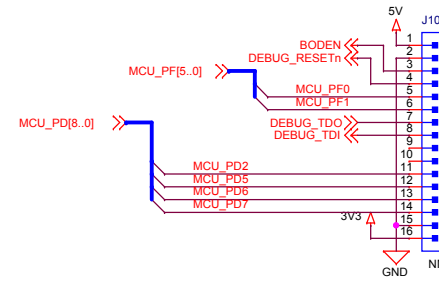

- 5V
- GND
- BODEN
- RST
- F0
- F1
- TDO
- TDI
- NC
- NC
- D2
- D5
- D6
- D7
- GND
- 3V3

PE Connections



PF Connections

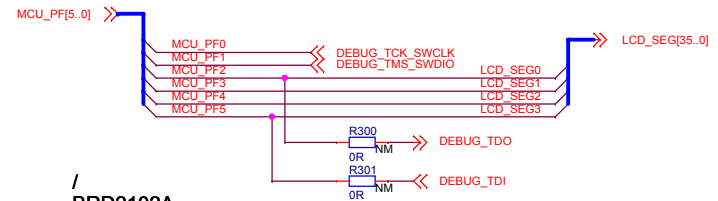

BRD2102A

<p>SILICON LABS</p>		Schematic Title	
		EFM32 Tiny Gecko 11 Starter Kit	
Designed: HEL		Approved: JNO	
Page Title		Signal Assignments	
Size: A3	BOM Doc No: <Cage Code>	Document number	Revision
Design Created Date: Tuesday, December 06, 2016		BRD2102A	A03
Sheet Created Date: Tuesday, December 06, 2016		Sheet Modified Date: Monday, May 22, 2017	Sheet 3 of 11

Power Select Switch: AEM/BAT

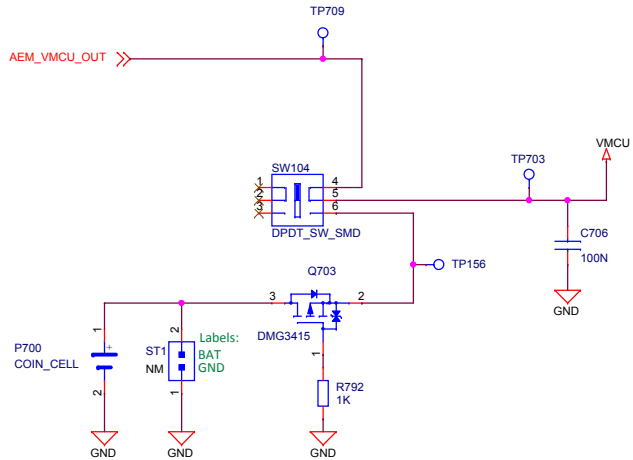

SWITCH POS	MODE DESCRIPTION
AEM	AEM Enabled, VMCU sourced from external 3.3V LDO powered by BC USB 5V supply
BAT	AEM Disabled, VMCU sourced from coin-cell battery or external power supply

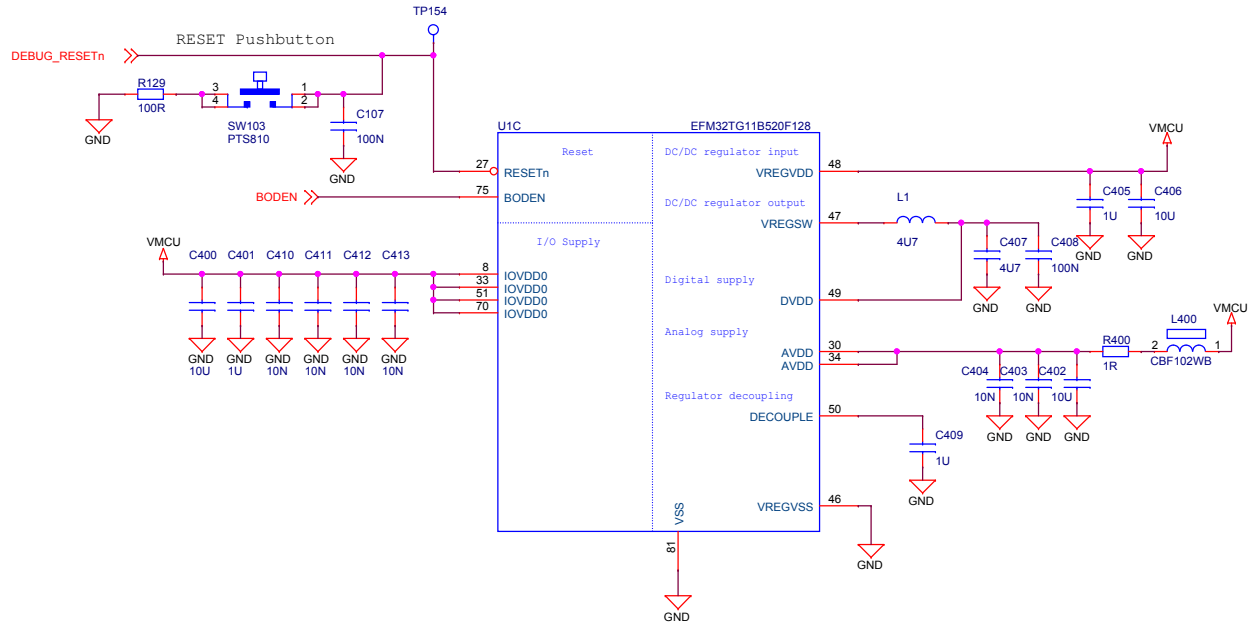

Capacitor for Backup Power Domain

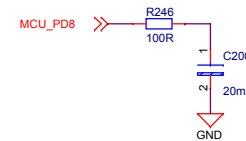

/
BRD2102A

 SILICON LABS		Schematic Title	
		EFM32 Tiny Gecko 11 Starter Kit	
Designed: HEL		Approved: JNO	
Page Title		Document number	
EFM32 Power		BRD2102A	
Size: A3	BOM Doc No: <Cage Code>	Sheet Created Date: Tuesday, December 06, 2016	Revision: A03
Design Created Date: Tuesday, December 06, 2016	Sheet Created Date: Tuesday, December 06, 2016	Sheet Modified Date: Monday, May 22, 2017	Sheet 4 of 11

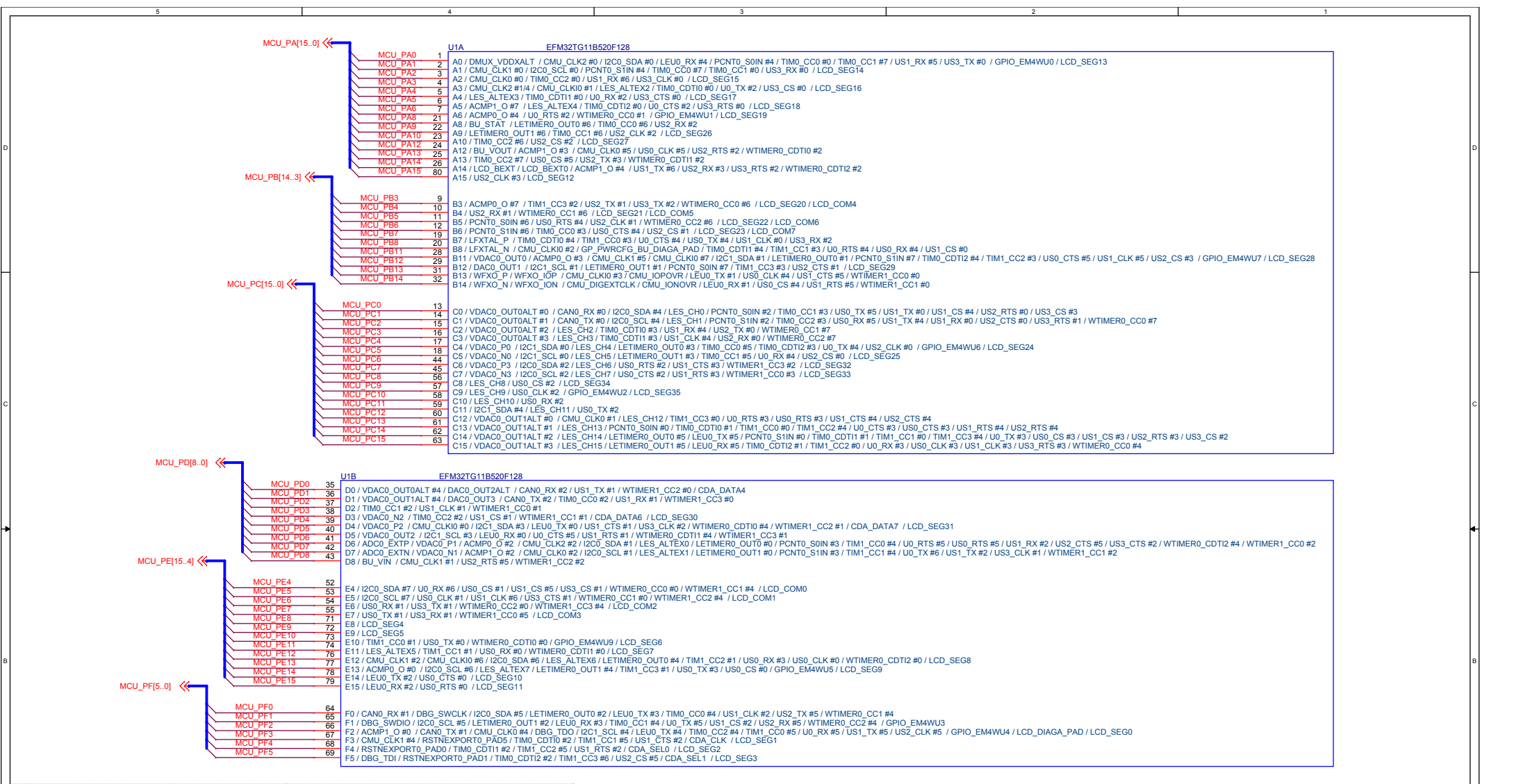

High Frequency Clock

Low Frequency Clock

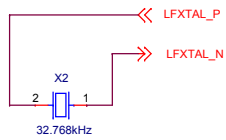
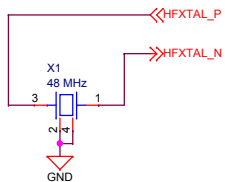

BRD2102A

		Schematic Title	
		EFM32 Tiny Gecko 11 Starter Kit	
Designed: HEL Approved: JNO		Page Title	
		EFM32 I/O	
Size A3	BOM Doc No: <Cage Code>	Document number BRD2102A	Revision A03
Design Created Date: Tuesday, December 06, 2016		Sheet Created Date Tuesday, December 06, 2016	Sheet Modified Date Monday, May 22, 2017
		Sheet 5 of 11	

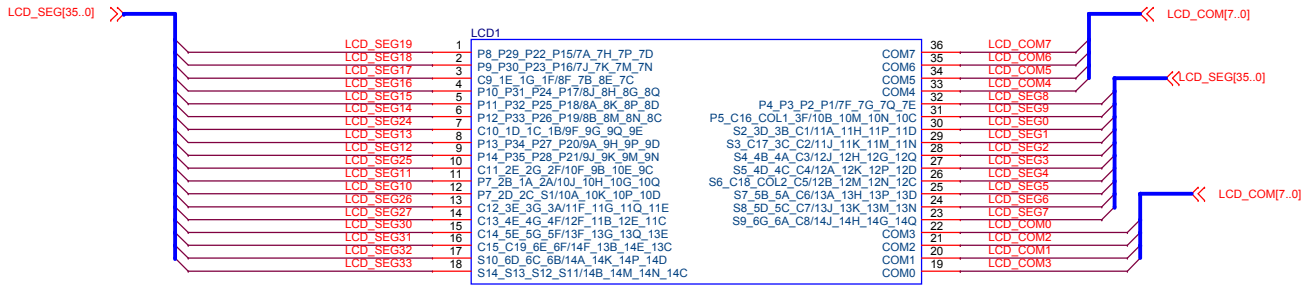

NOTE: COM0 and COM3 signals switched

LCD Charge Pump Capacitor

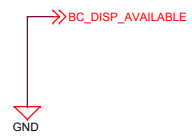
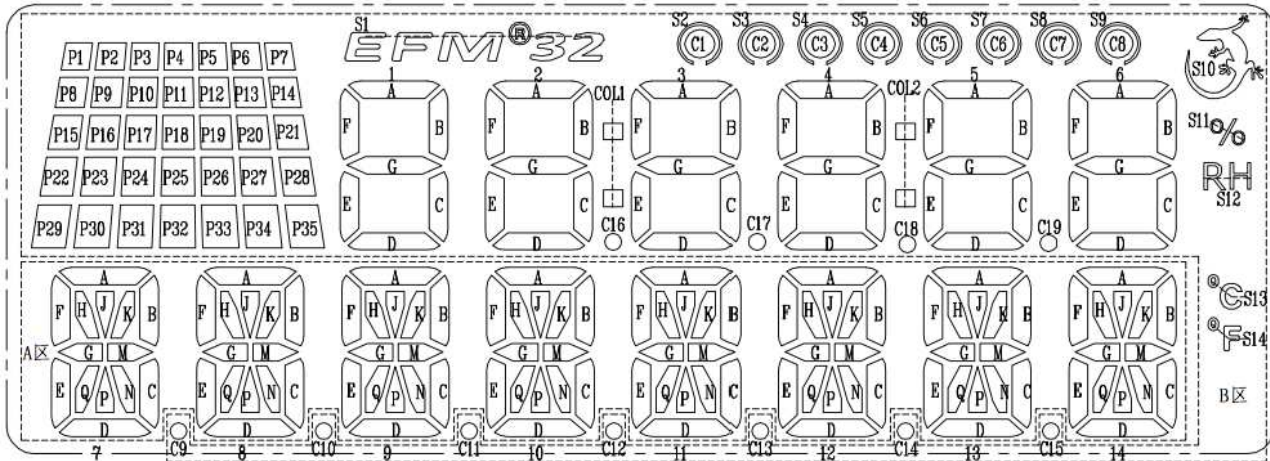
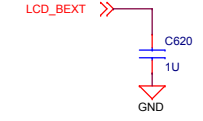

PIN	1	2	3	4	5	6	7	8	9	10	11	12	13	14	15	16	17	18
COM0	P8	P9	C9	P10	P11	P12	C10	P13	P14	C11	P7	P6	C12	C13	C14	C15	S10	S14
COM1	P29	P30	1E	P31	P32	P33	1D	P34	P35	2E	2B	2D	3E	4E	5E	C19	6D	S13
COM2	P22	P23	1G	P24	P25	P26	1C	P27	P28	2G	1A	2C	3G	4G	5G	6E	6C	S12
COM3	P15	P16	1F	P17	P18	P19	1B	P20	P21	2F	2A	S1	3A	4F	5F	6F	6B	S11
COM4	7A	7J	8F	8J	8A	8B	9F	9A	9J	10F	10J	10A	11F	12F	13F	14F	14A	14B
COM5	7H	7K	7B	8H	8K	8M	9G	9H	9K	10H	10K	11G	11B	13G	13B	14K	14M	
COM6	7P	7M	8E	8G	8P	8N	9Q	9P	9M	10E	10G	10P	11Q	12E	13Q	14E	14P	14N
COM7	7D	7N	7C	8Q	8D	8C	9E	9D	9N	9C	10Q	10D	11E	11C	13E	13C	14D	14C

PIN	19	20	21	22	23	24	25	26	27	28	29	30	31	32	33	34	35	36
COM0	COM0				S9	S8	S7	S6	S5	S4	S3	S2	P5	P4				
COM1		COM1			6G	5D	5B	C18	C18	4D	4B	C17	3D	C16	P3			
COM2			COM2		6A	5C	5A	COM2	4C	4A	3C	3B	COL1	P2				
COM3				COM3	C8	C7	C6	C5	C4	C3	C2	C1	3F	P1				
COM4					14J	13J	13A	12B	12A	12J	11J	11A	10B	7F	COM4			
COM5					14H	13K	13H	12M	12K	12H	11K	11H	10M	7G		COM5		
COM6					14G	13M	13P	12N	12P	12G	11M	11P	10N	7Q			COM6	
COM7					14Q	13N	13D	12C	12D	12Q	11N	11D	10C	7E				COM7

BRD2102A

		Schematic Title	
		EFM32 Tiny Gecko 11 Starter Kit	
Designed: HEL Approved: JNO		Page Title	
		LCD	
Size: A3 BOM Doc No: <Cage Code>		Document number	
		BRD2102A	
Design Created Date: Tuesday, December 06, 2016		Revision	
		A03	
Sheet Created Date: Tuesday, December 06, 2016		Sheet Modified Date	
		Monday, May 22, 2017	
Sheet 6 of 11		Revision	
		A03	

MCU power regulator

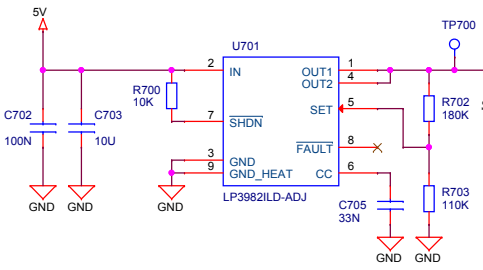

Isolation switch

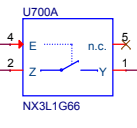

This goes to the slide switch, where it can be selected as the power source.

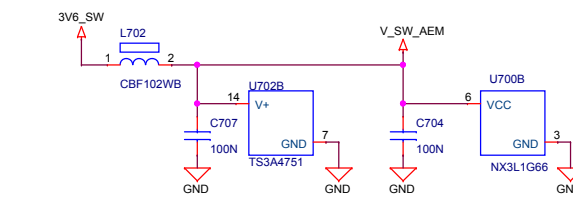

MCU current sense

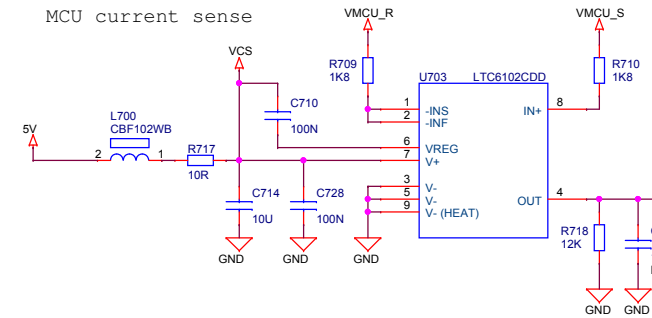

MCU Voltage Sense

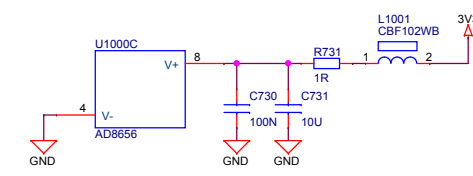
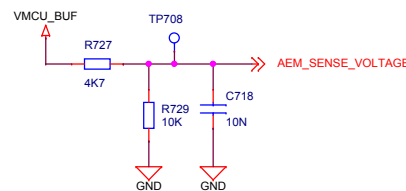

AEM Calibration

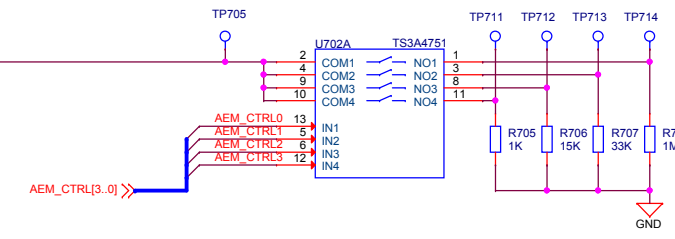

AEM_CTRL	Calibration Current
0x1	3.30 uA
0x2	100 uA
0x4	220 uA
0x6	320 uA
0x8	3.30 mA

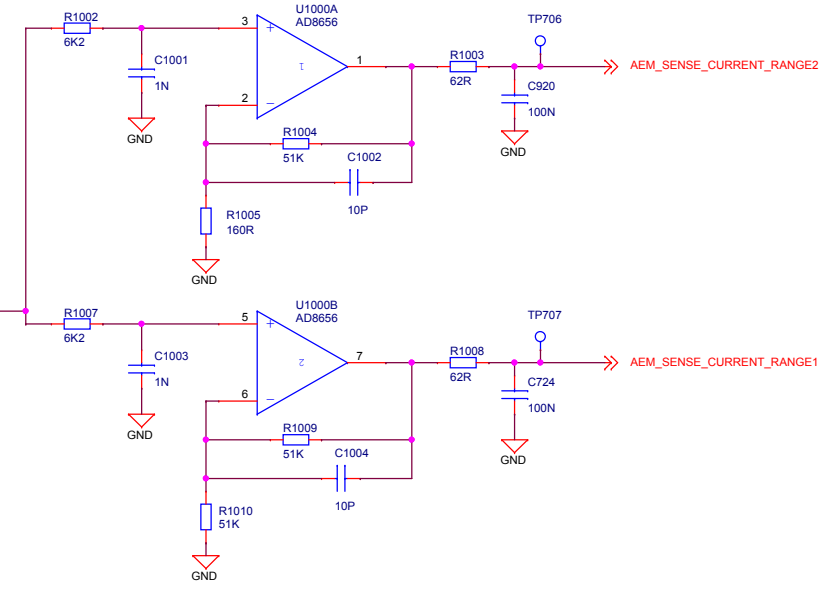

BRD2102A

		Schematic Title	
		EFM32 Tiny Gecko 11 Starter Kit	
Designed: HEL Approved: JNO		Page Title	
		Advanced Energy Monitor	
Size A3	BOM Doc No: <Cage Code>	Document number	Revision
Design Created Date: Tuesday, December 06, 2016		BRD2102A	A03
Sheet Created Date: Tuesday, December 06, 2016		Sheet Modified Date: Monday, May 22, 2017	Sheet 7 of 11

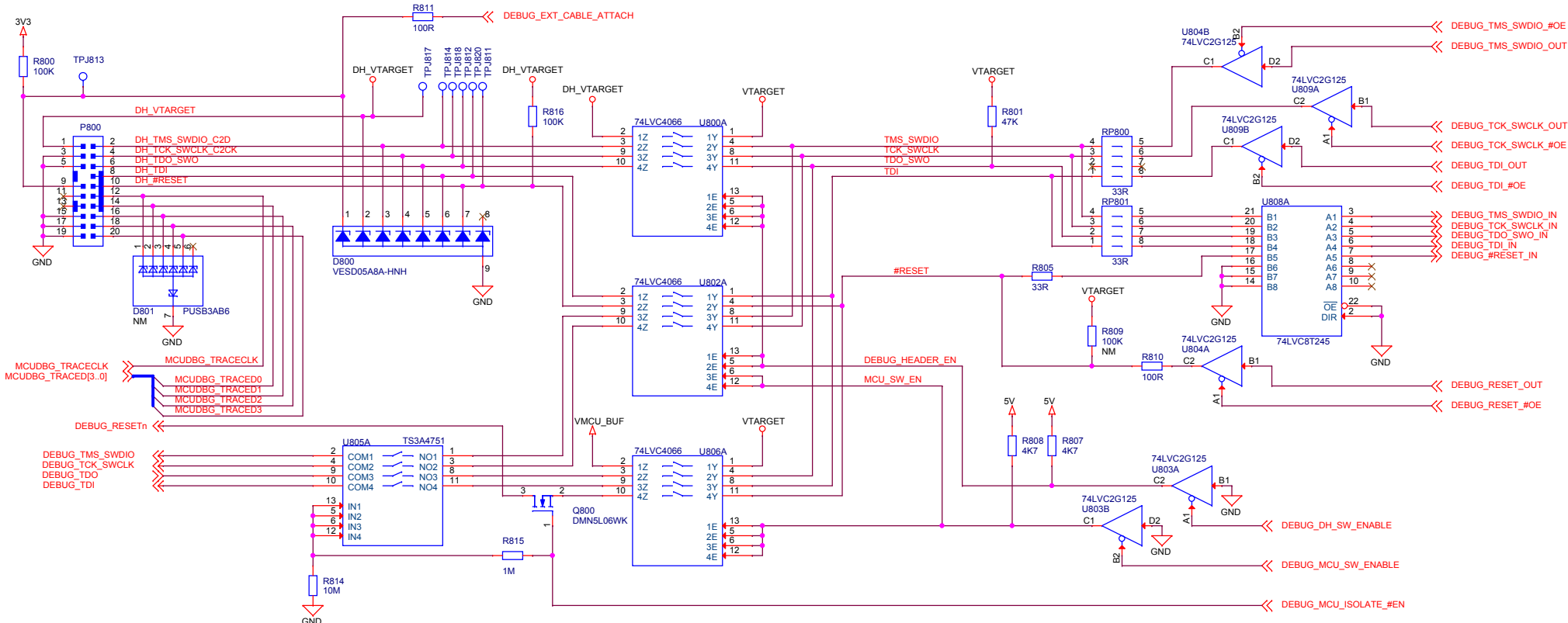

Power & Decoupling

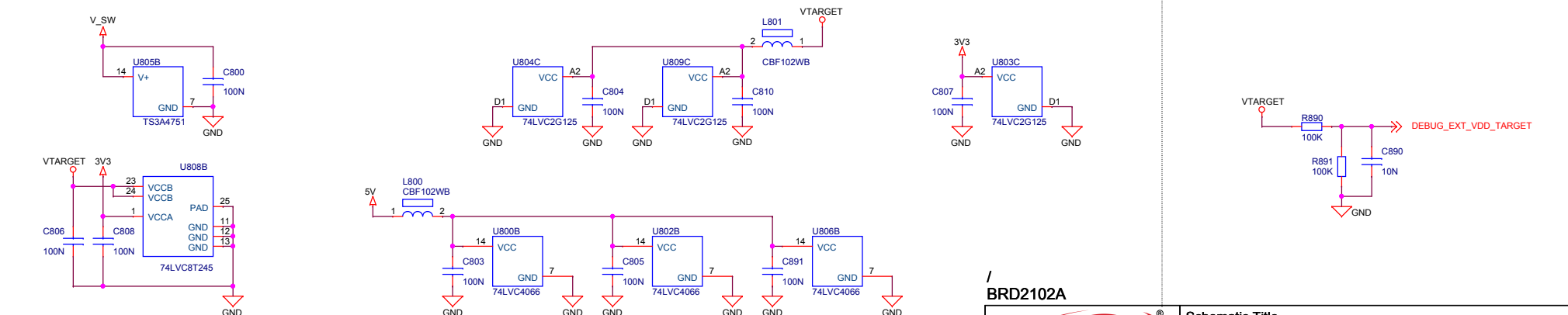

Mode	DEBUG_MCU_SW_ENABLE	DEBUG_DH_SW_ENABLE	DEBUG_BUF_#OE	ISOLATE_#EN	DH_VTARGET	VTARGET
Debug Out	0	1	0	0	External voltage	External voltage
MCU Debug	1	0	0	1	Disconnected	VMCU
Debug In	1	1	1	1	VMCU	VMCU
Debug Off	1	1	1	0	-	-

BRD2102A

Schematic Title
EFM32 Tiny Gecko 11 Starter Kit

Page Title
Debug Interface

Document number
BRD2102A

Design Created Date:
Tuesday, December 06, 2016

Approved:
JNO

Size
A3

BOM Doc No:
<Cage Code>

Design Created Date:
Tuesday, December 06, 2016

Revision
A03

Sheet Created Date
Tuesday, December 06, 2016

Sheet Modified Date
Monday, May 22, 2017

Sheet
8 of 11

Virtual COM Port Interface

Level Shift

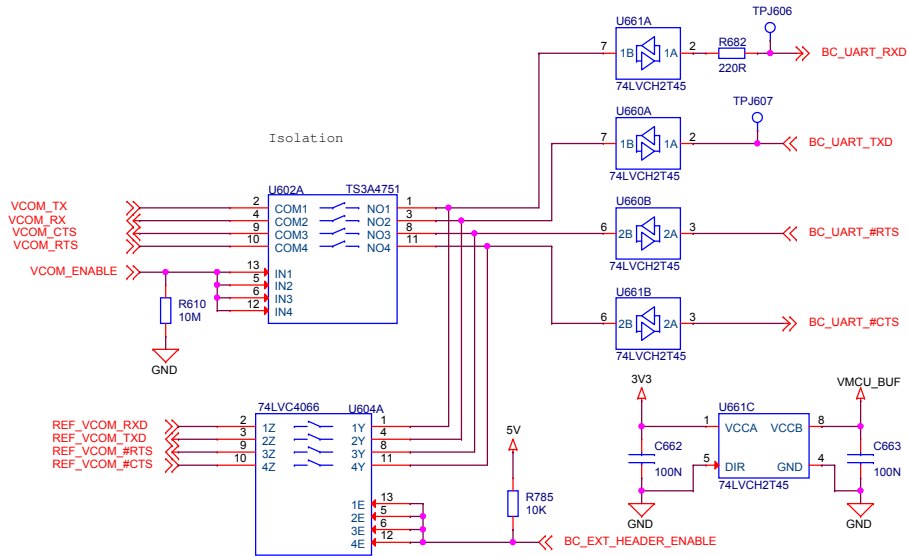

3V3 Regulator

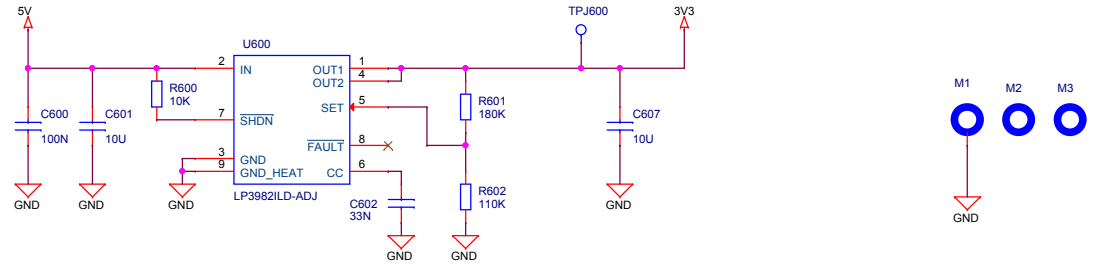

VMCU Voltage Mirror

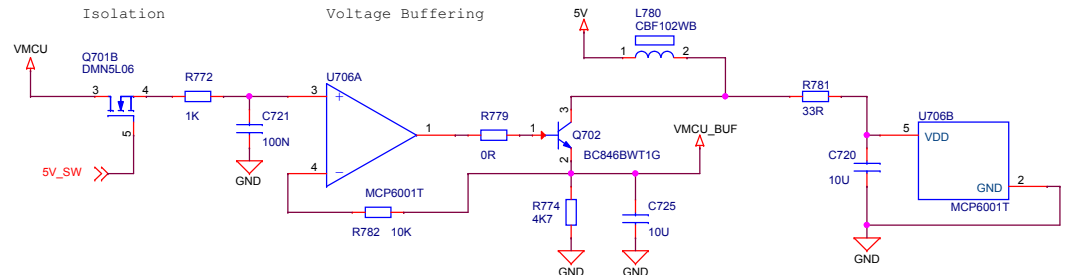

Power Supply for Analog Switches

The USB VBUS voltage is used to bias these transistors, turning the P-Channel MOSFETs (Q700) off, and the N-Channel MOSFETs (Q701) on.

J-Link USB Cable	PMOS State	NMOS State	V_SW	VMCU_SENSE
Connected	Off	ON	3.6V	VMCU
Disconnected	ON	OFF	VMCU	Isolated

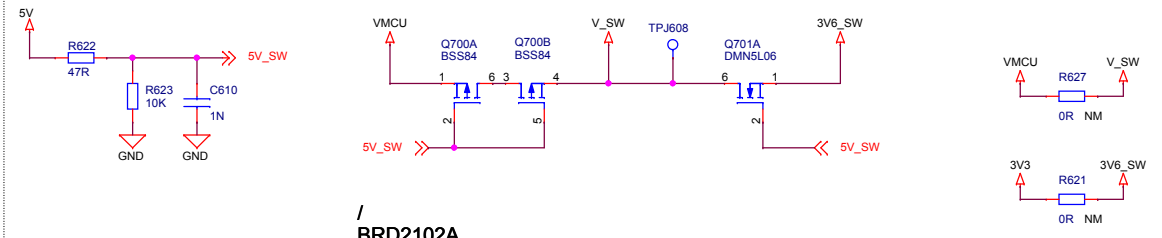
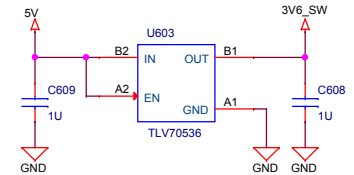

EXTERNAL BOARD

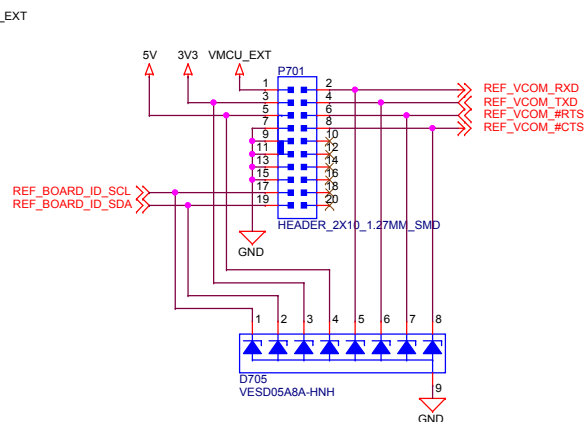

BRD2102A



SILICON LABS

Schematic Title
EFM32 Tiny Gecko 11 Starter Kit

Page Title
Signal Assignments

Designed: HEL	Approved: JNO	Document number BRD2102A	Revision A03
Size A3	BOM Doc No: <Cage Code>	Sheet Created Date Tuesday, December 06, 2016	Sheet Modified Date Monday, May 22, 2017
Design Created Date: Tuesday, December 06, 2016		Sheet Created Date Tuesday, December 06, 2016	Sheet Modified Date Monday, May 22, 2017
Sheet 9 of 11			

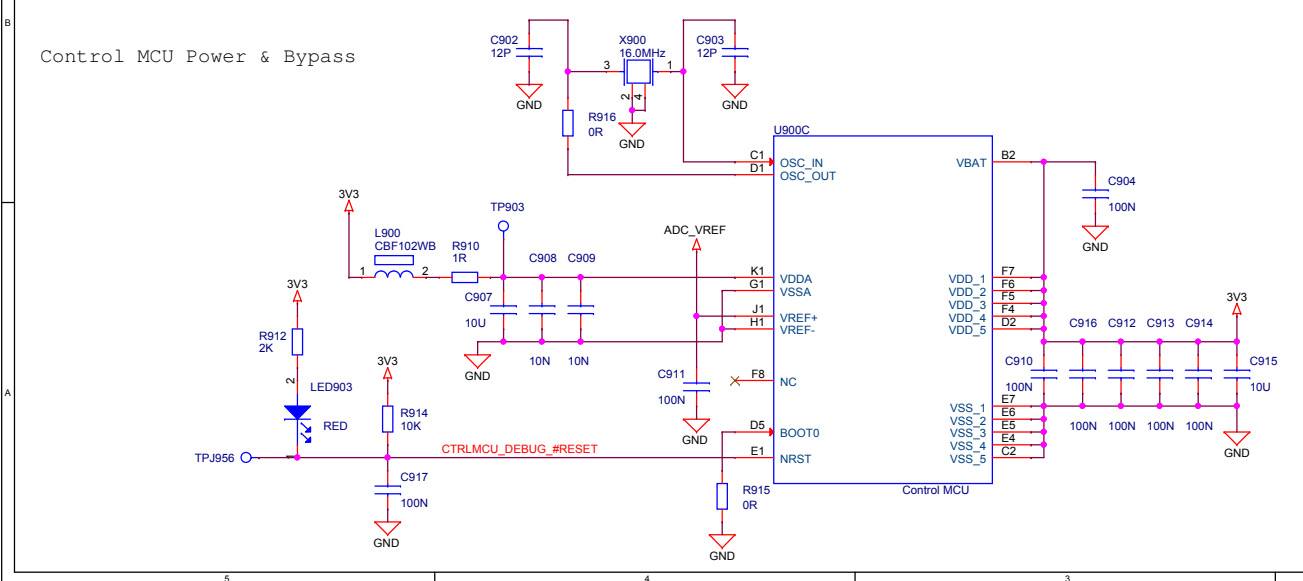
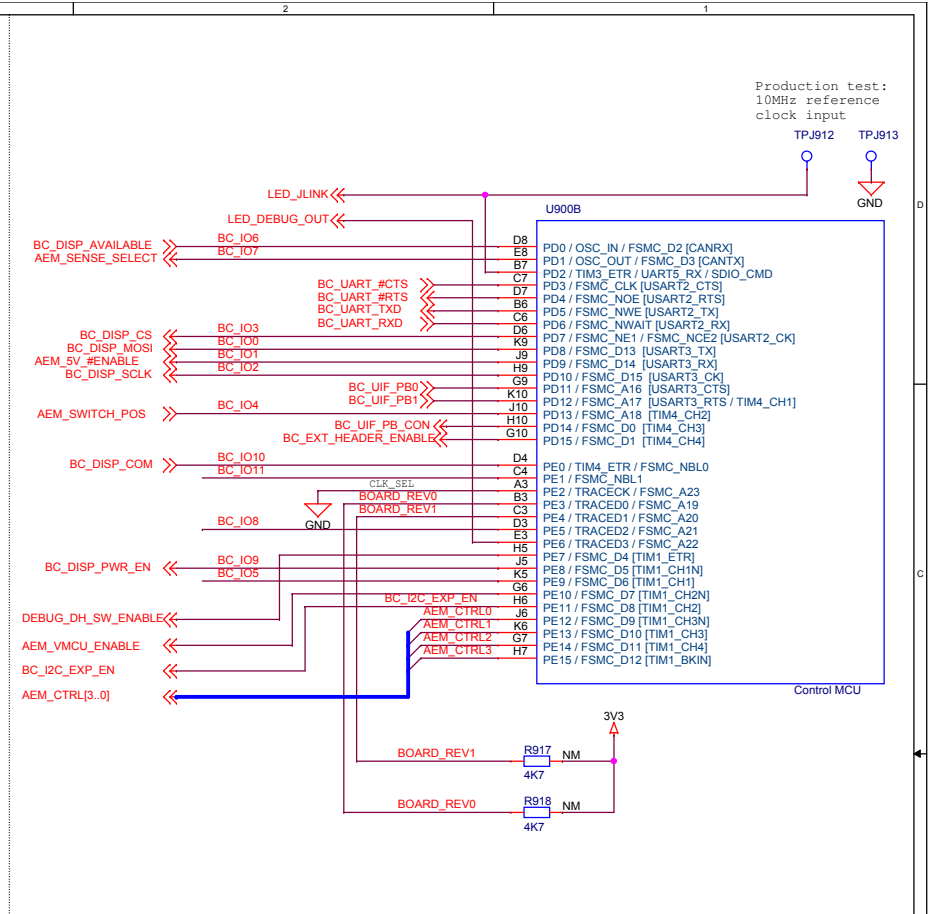
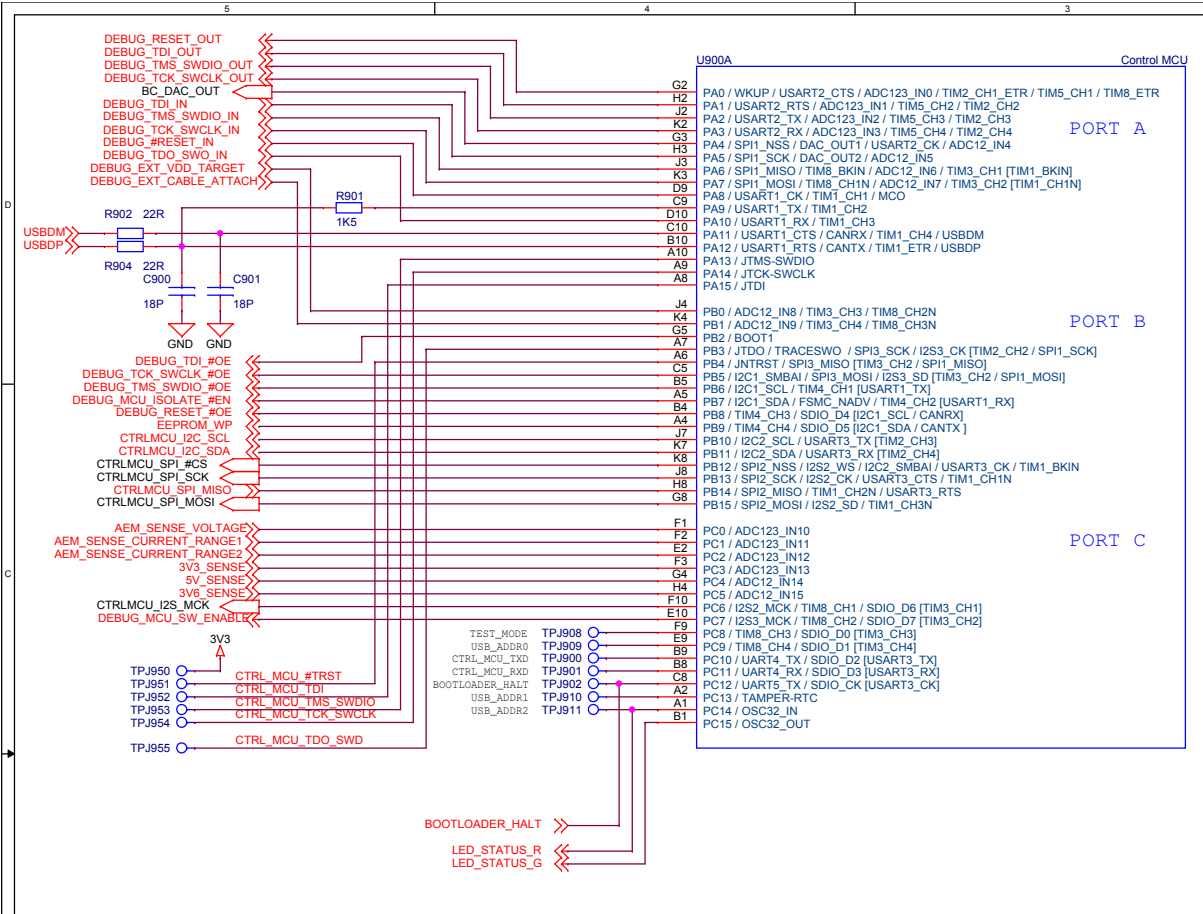

BRD2102A

SILICON LABS

Schematic Title
EFM32 Tiny Gecko 11 Starter Kit

Page Title
Board Controller MCU

Designed: HEL	Approved: JNO	Document number BRD2102A	Revision A03
Size A3	BOM Doc No: <Cage Code>	Sheet Created Date Tuesday, December 06, 2016	Sheet Modified Date Monday, May 22, 2017
Design Created Date: Tuesday, December 06, 2016		Sheet Created Date Tuesday, December 06, 2016	Sheet 10 of 11

J-Link USB Port

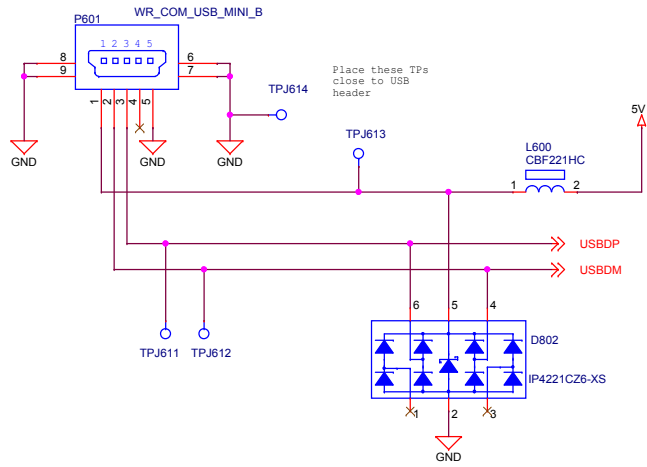

ADC reference voltage

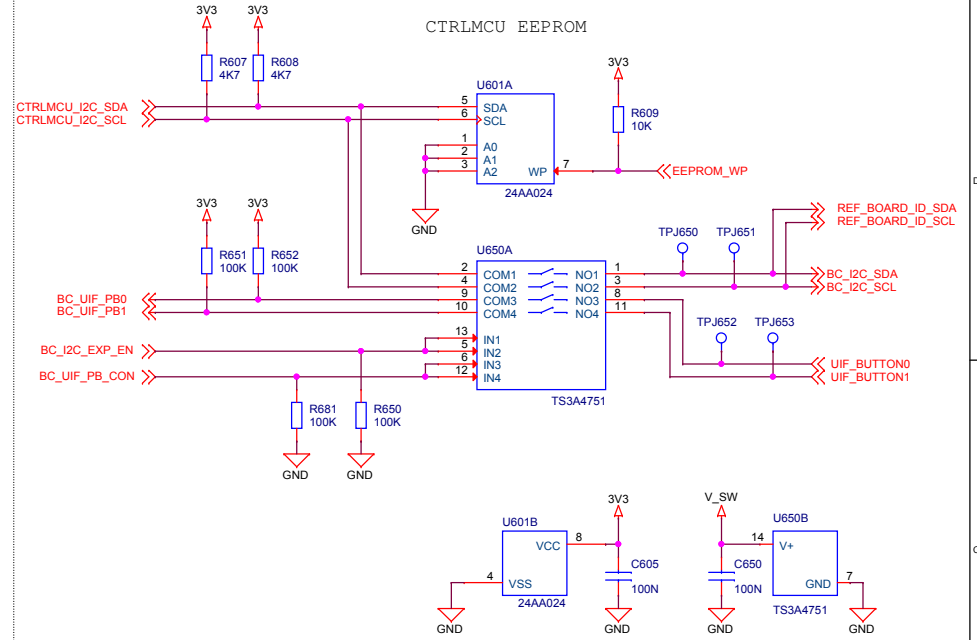
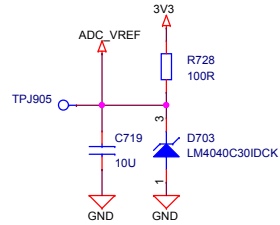

Indicators:

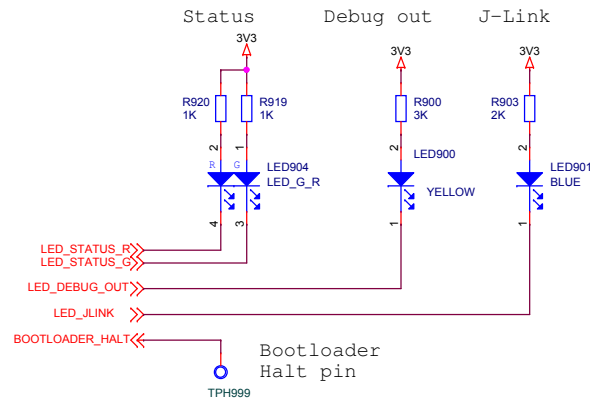

CTRLMCU SERIAL FLASH

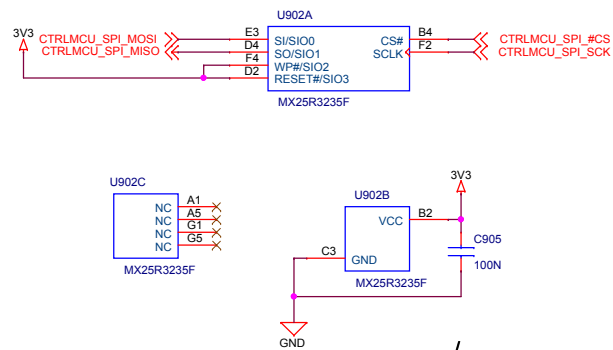

POWER SENSE

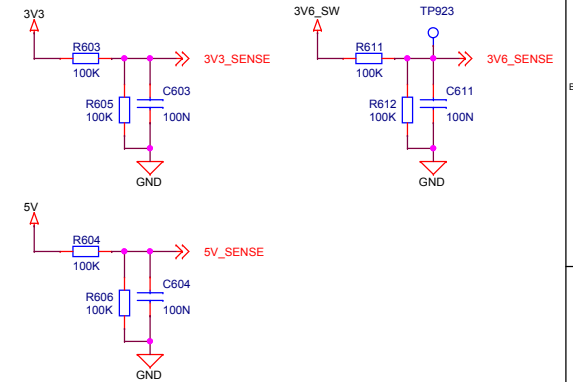

BRD2102A

		Schematic Title	
		EFM32 Tiny Gecko 11 Starter Kit	
Designed: HEL Approved: JNO		Page Title	
		Board Controller Misc	
Size A3	BOM Doc No: <Cage Code>	Document number	Revision
Design Created Date: Tuesday, December 06, 2016		BRD2102A	A03
	Sheet Created Date: Tuesday, December 06, 2016	Sheet Modified Date: Monday, May 22, 2017	Sheet 11 of 11