



EFM32PG12 Pearl Gecko STK	
Board Function	Page
Title Page	1
User Interface	2
EFM32 Signal Assignments	3
EFM32 Power	4
EFM32 I/O	5
STK Board Controller	6
Advanced Energy Monitor	7
Debug Interface	8
Board Controller	9
Power & Misc	10

Revision History	
Rev.	Description
A00	Initial release

LEGAL NOTICE:  
 SILICON LABORATORIES INC. ("SILICON LABS") AND/OR ITS LICENSORS DO NOT WARRANT THE ACCURACY OR COMPLETENESS OF THIS SCHEMATIC OR ANY INFORMATION CONTAINED WITHIN THIS SCHEMATIC. IT IS PROVIDED "AS-IS" FOR REFERENCE ONLY. SILICON LABS DOES NOT WARRANT THAT THIS DESIGN WILL MEET THE SPECIFICATIONS, BE SUITABLE FOR YOUR APPLICATION OR FIT FOR ANY PARTICULAR PURPOSE, OR WILL OPERATE IN YOUR IMPLEMENTATION. SILICON LABS AND ITS LICENSORS DO NOT WARRANT THAT THE DESIGN IMPLIED IN THIS SCHEMATIC IS PRODUCTION-WORTHY. YOU SHOULD COMPLETELY VALIDATE AND TEST YOUR DESIGN IMPLEMENTATION TO CONFIRM SYSTEM FUNCTIONALITY FOR YOUR APPLICATION.



/ EFM32PG STK		Schematic Title	
		<b>EFM32PG12 Pearl Gecko Starter Kit</b>	
Designed: HEL Approved: JNO		Page Title <b>Title Page</b>	
Size: A3 BOM Doc No: <Cage Code>	Document number <b>BRD2501A</b>	Revision <b>A00</b>	
Design Created Date: Wednesday, December 03, 2008	Sheet Created Date Saturday, March 21, 2009	Sheet Modified Date Thursday, December 22, 2016	Sheet 1 of 10

### LESENSE LC-Sensor

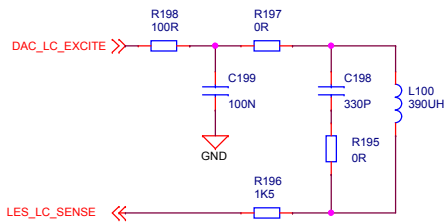

### User LEDs

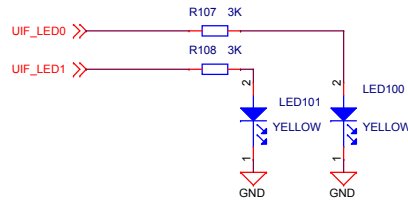

### User Pushbuttons

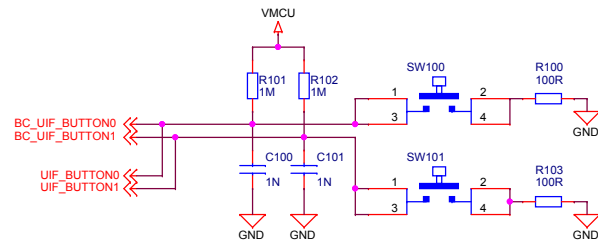

### Touch Pads

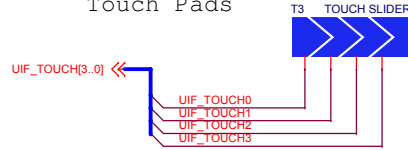

### Memory LCD-TFT Display & Multiplexer

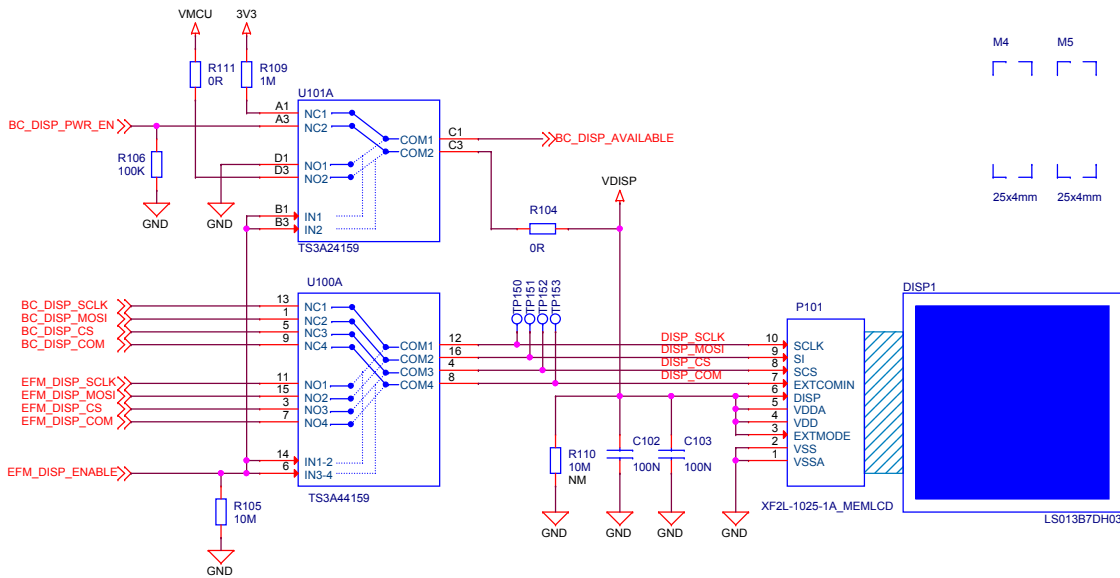

EFM_DISP_ENABLE	DISP_CTRL	VDISP	BC_DISP_AVAILABLE
1	EFM	VMCU	0
0	BC	BC_DISP_PWR_EN	1

The EFM32 always controls ownership of the display using the EFM\_DISP\_ENABLE signal.

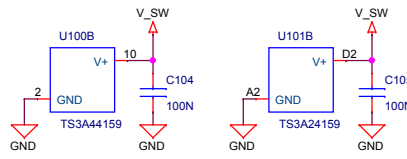

### EXP Header

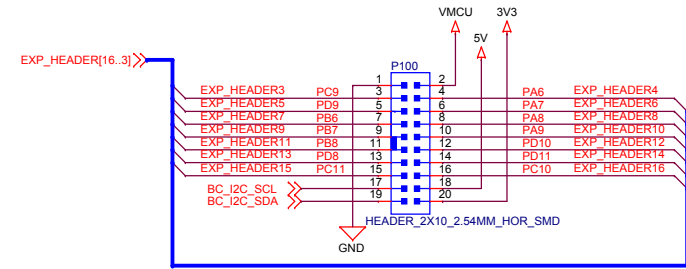

#### EXP-Header Functionality

Pin	Signal	Functionality
1	GND	
3	PC9	
5	PD9	
7	PB6	US3_TX #10 I2C1_SDA#6
9	PB7	US3_RX #10 I2C1_SCL#6
11	PB8	US3_CLK #10
13	PD8	US3_CS #29
15	PC11	I2C0_SCL#15
17		Reserved for EXP Board Identification
19		Reserved for EXP Board Identification

Pin	Signal	Functionality
2	VMCU	
4	PA6	US2_TX #1
6	PA7	US2_RX #1
8	PA8	US2_CLK #1
10	PA9	US2_CS #1
12	PD10	LEU0_TX #18
14	PD11	LEU0_RX #18
16	PC10	I2C0_SDA#15
18	5V	
20	3V3	

### Relative Humidity & Temperature Sensor

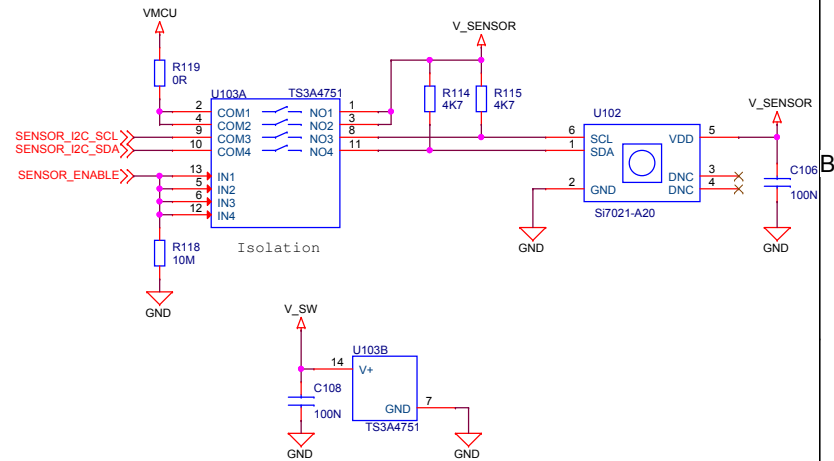

### EFM32PG STK

		Schematic Title	
		<b>EFM32PG12 Pearl Gecko Starter Kit</b>	
Design: HEL Approved: JNO		Page Title	
		<b>User Interfaces</b>	
Size: A3	BOM Doc No:	Document number	Revision
Design Created Date:	Wednesday, December 03, 2008	BRD2501A	A00
Sheet Created Date:	Friday, October 31, 2014	Sheet Modified Date:	Friday, December 23, 2016
		Sheet 2 of 10	

### PA Connections

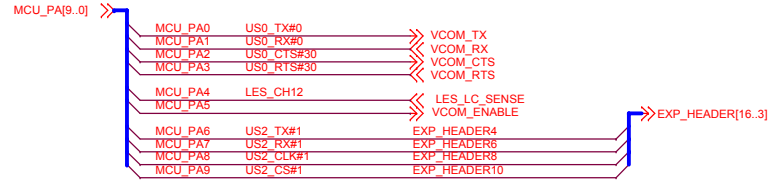

### PB Connections

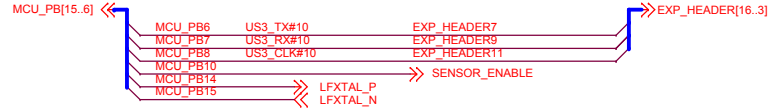

### PC Connections

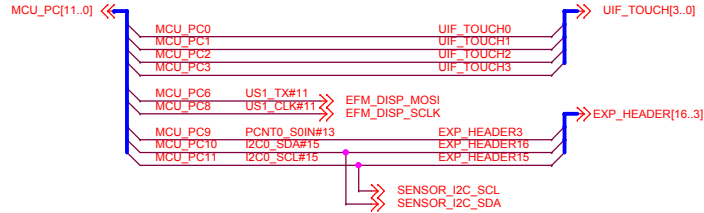

### PD Connections

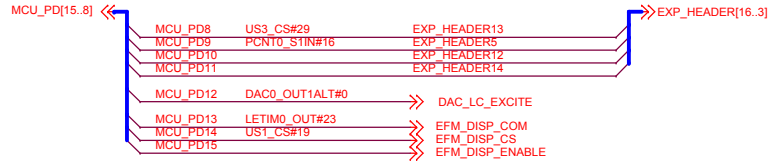

### PF Connections

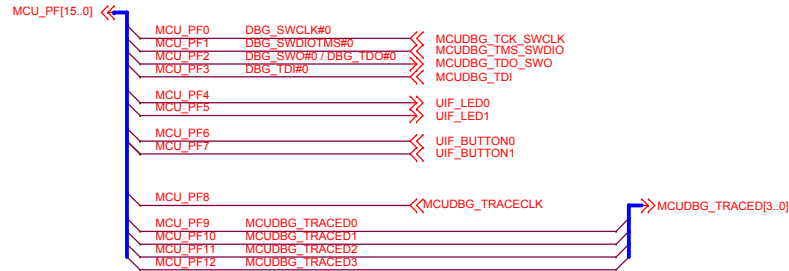

### Breakout Connections

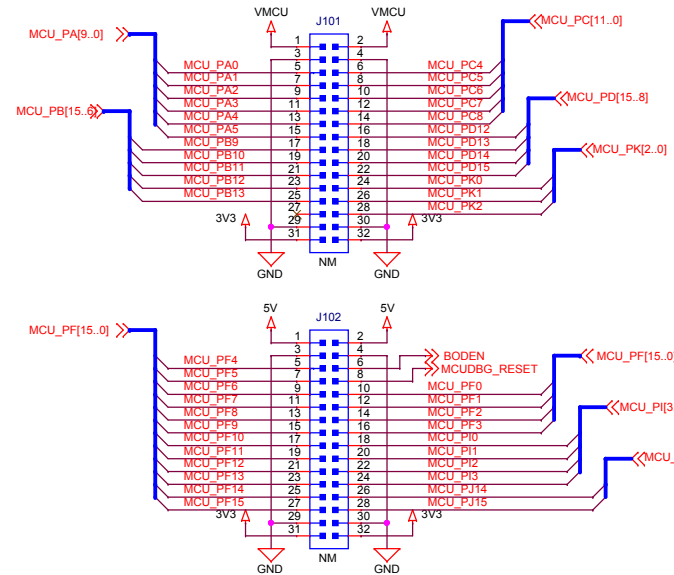

#### Breakout header labels:

VMCU	VMCU
GND	GND
PA0	PC4
PA1	PC5
PA2	PC6
PA3	PC7
PA4	PC8
PA5	PD12
PB9	PD13
PB10	PD14
PB11	PD15
PB12	PK0
PB13	PK1
NC	PK2
GND	GND
3V3	3V3

5V	5V
GND	GND
PF4	BODEN
PF5	RST
PF6	PFO
PF7	PF1
PF8	PF2
PF9	PF3
PF10	PI0
PF11	PI1
PF12	PI2
PF13	PI3
PF14	PI4
PF15	PI5
GND	GND
3V3	3V3



Schematic Title

**EFM32PG12 Pearl Gecko Starter Kit**

Page Title

**EFM32 Signal Assignments**

Designed: HEL  
Approved: JNO

Document number

**BRD2501A**

Revision

**A00**

Size: A3  
BOM Doc No: <Cage Code>

Sheet Created Date  
Friday, October 31, 2014

Sheet Modified Date  
Thursday, December 15, 2016

Sheet  
3 of 10

Power Select Switch: AEM/BAT

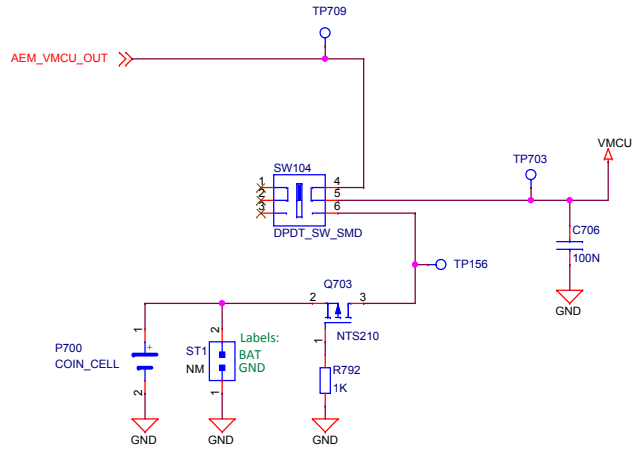

SWITCH POS	MODE DESCRIPTION
AEM	AEM Enabled, VMCU sourced from external 3.3V LDO powered by BC USB 5V supply
BAT	AEM Disabled, VMCU sourced from coin-cell battery or external power supply

EFM32 Power and Decoupling

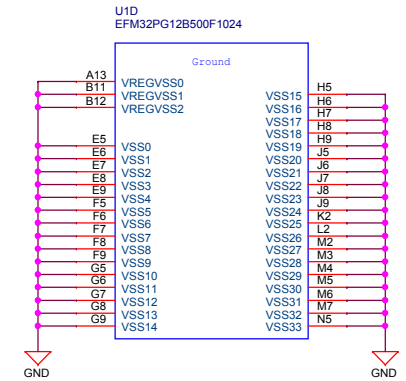
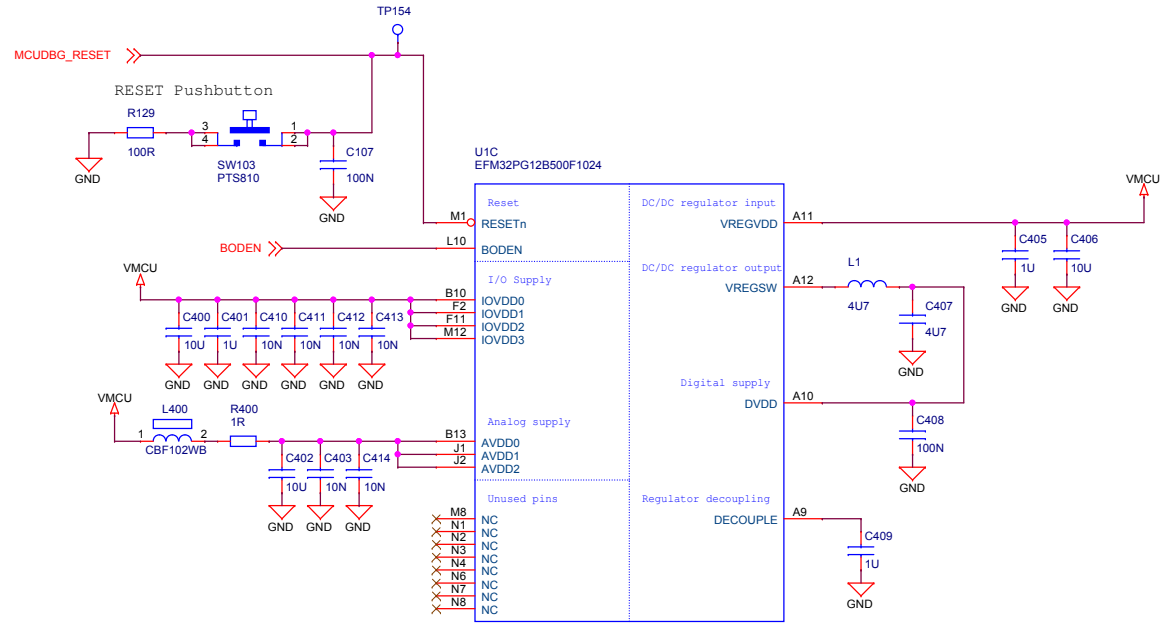

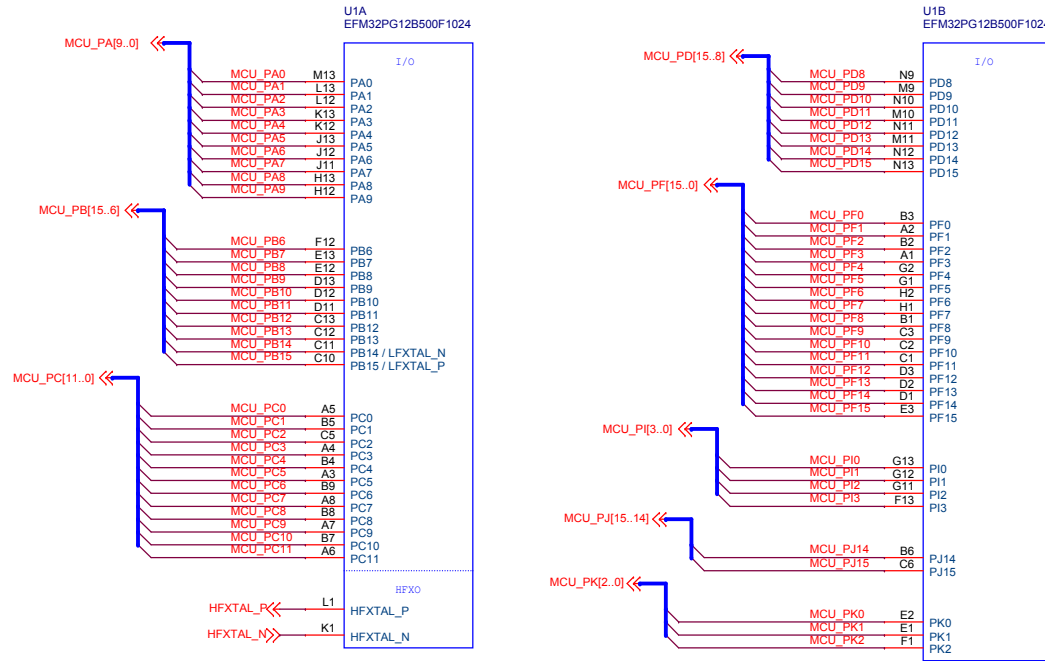

		Schematic Title	
		<b>EFM32PG12 Pearl Gecko Starter Kit</b>	
Designed: HEL Approved: JNO		Page Title	
		<b>EFM32 Power</b>	
Size: A3	BOM Doc No: <Cage Code>	Document number	
Design Created Date: Wednesday, December 03, 2008		<b>BRD2501A</b>	
Sheet Created Date: Friday, October 31, 2014		Sheet Modified Date: Thursday, December 15, 2016	
Revision		Sheet 4 of 10	

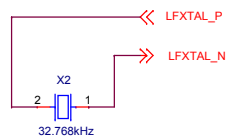
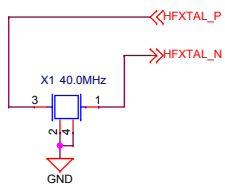

High Frequency Clock

Low Frequency Clock



		Schematic Title	
		<b>EFM32PG12 Pearl Gecko Starter Kit</b>	
Designed: HEL Approved: JNO		Page Title	
		<b>EFM32 I/O</b>	
Size: A3	BOM Doc No: <Cage Code>	Document number	Revision
Design Created Date: Wednesday, December 03, 2008		<b>BRD2501A</b>	A00
	Sheet Created Date: Monday, November 17, 2014	Sheet Modified Date: Thursday, December 15, 2016	Sheet 5 of 10

Board Controller Functional Block

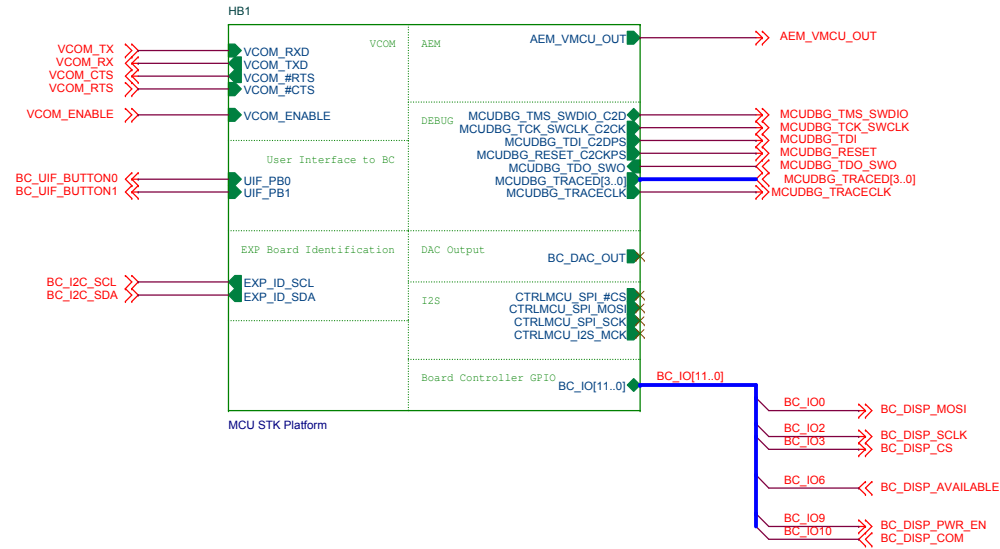

 <b>SILICON LABS</b>		Schematic Title	
		<b>EFM32PG12 Pearl Gecko Starter Kit</b>	
Designed: HEL Approved: JNO		Page Title	
		<b>STK Board Controller</b>	
Size: A3	BOM Doc No: <Cage Code>	Document number	Revision
Design Created Date: Wednesday, December 03, 2008	Sheet Created Date: Friday, October 31, 2014	Document number: <b>BRD2501A</b>	Revision: A00
	Sheet Modified Date: Thursday, December 15, 2016		Sheet 6 of 10

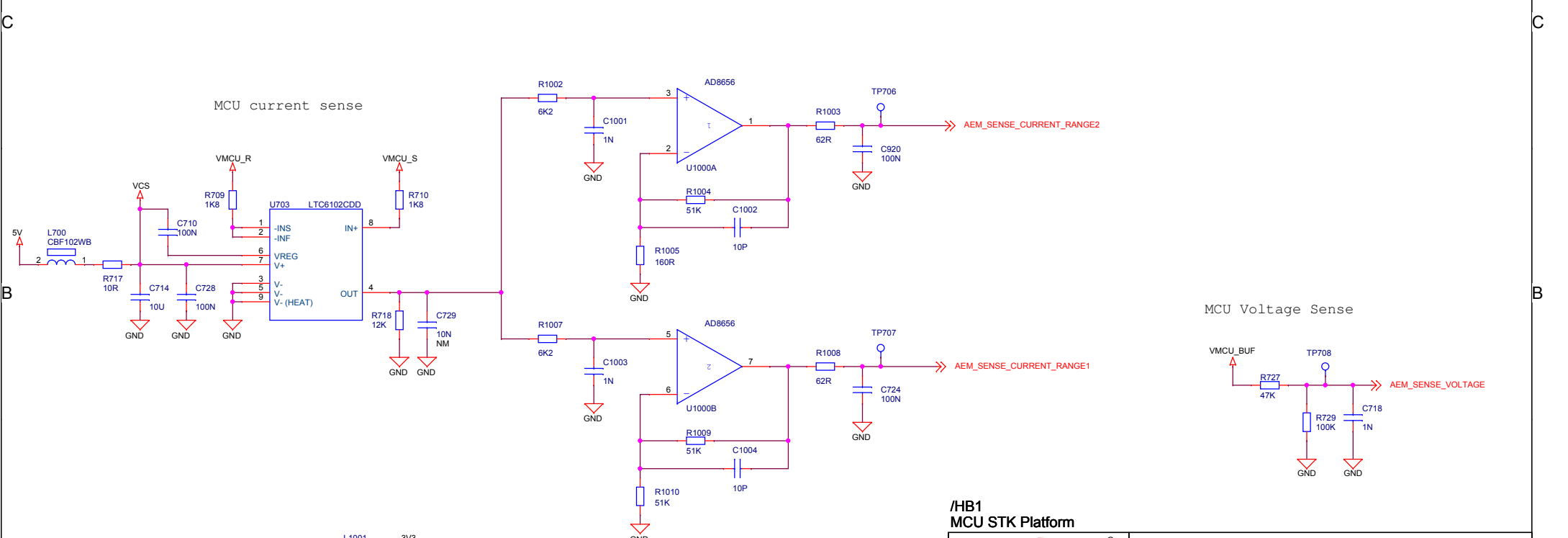
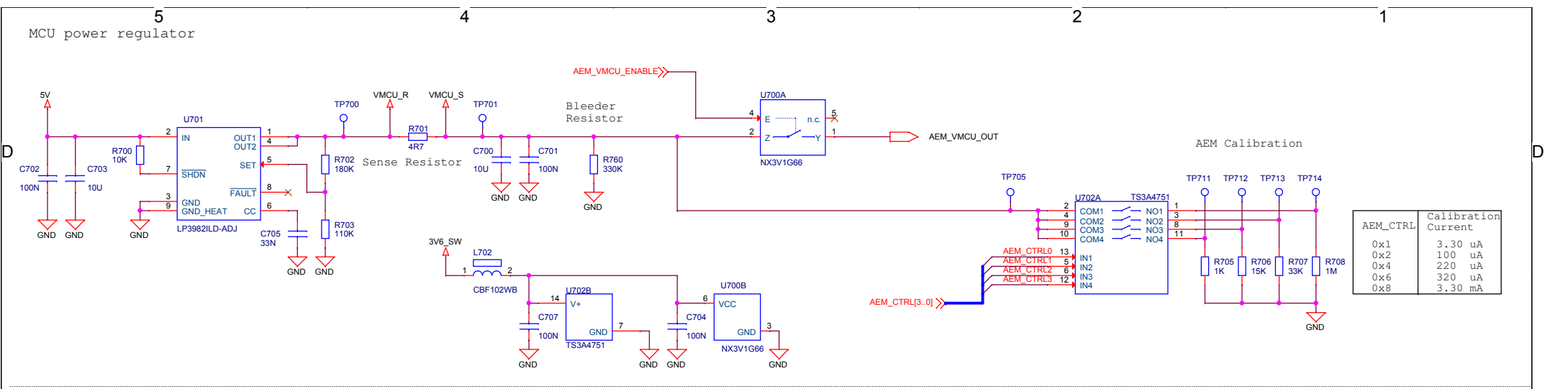

**/HB1**  
MCU STK Platform

**SILICON LABS**

Designed: DDB      Approved: JNO

Size: A3      BOM Doc No: <Cage Code>

Design Created Date: Monday, May 12, 2014

<b>Schematic Title</b>		
<b>EFM32PG12 Pearl Gecko Starter Kit</b>		
<b>Page Title</b>		
<b>Advanced Energy Monitor</b>		
<b>Document number</b>		
<b>BRD2501A</b>		
<b>Revision</b>	<b>Revision</b>	
<b>A00</b>	<b>A00</b>	
<b>Sheet Created Date</b>	<b>Sheet Modified Date</b>	<b>Sheet</b>
Tuesday, May 13, 2014	Thursday, December 15, 2016	7 of 10

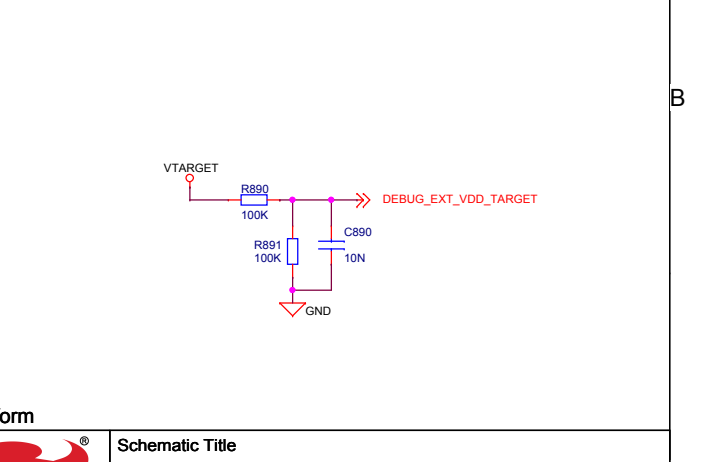
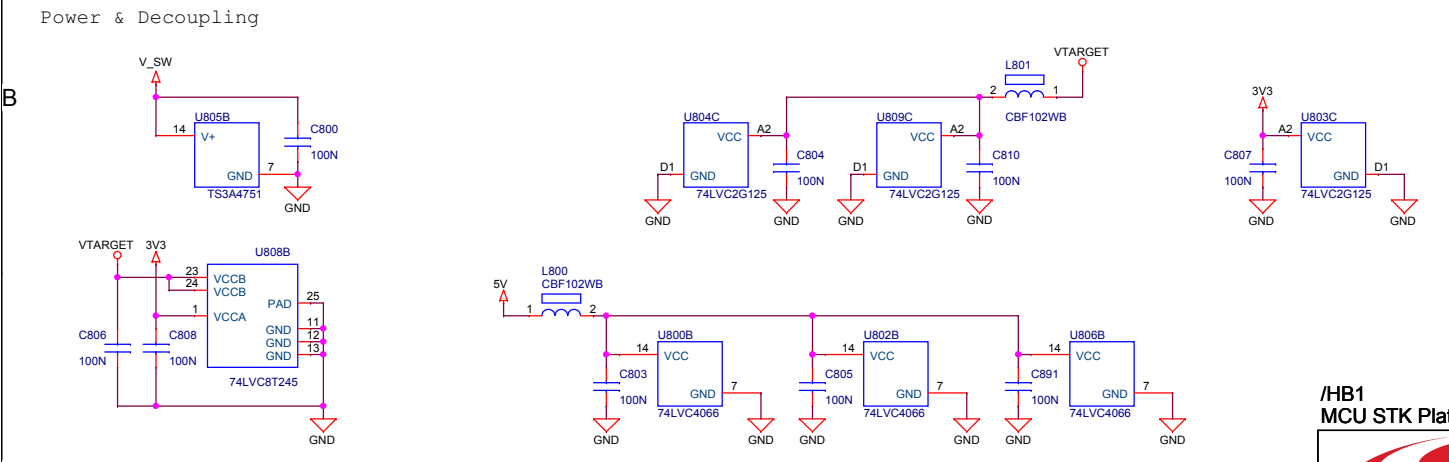
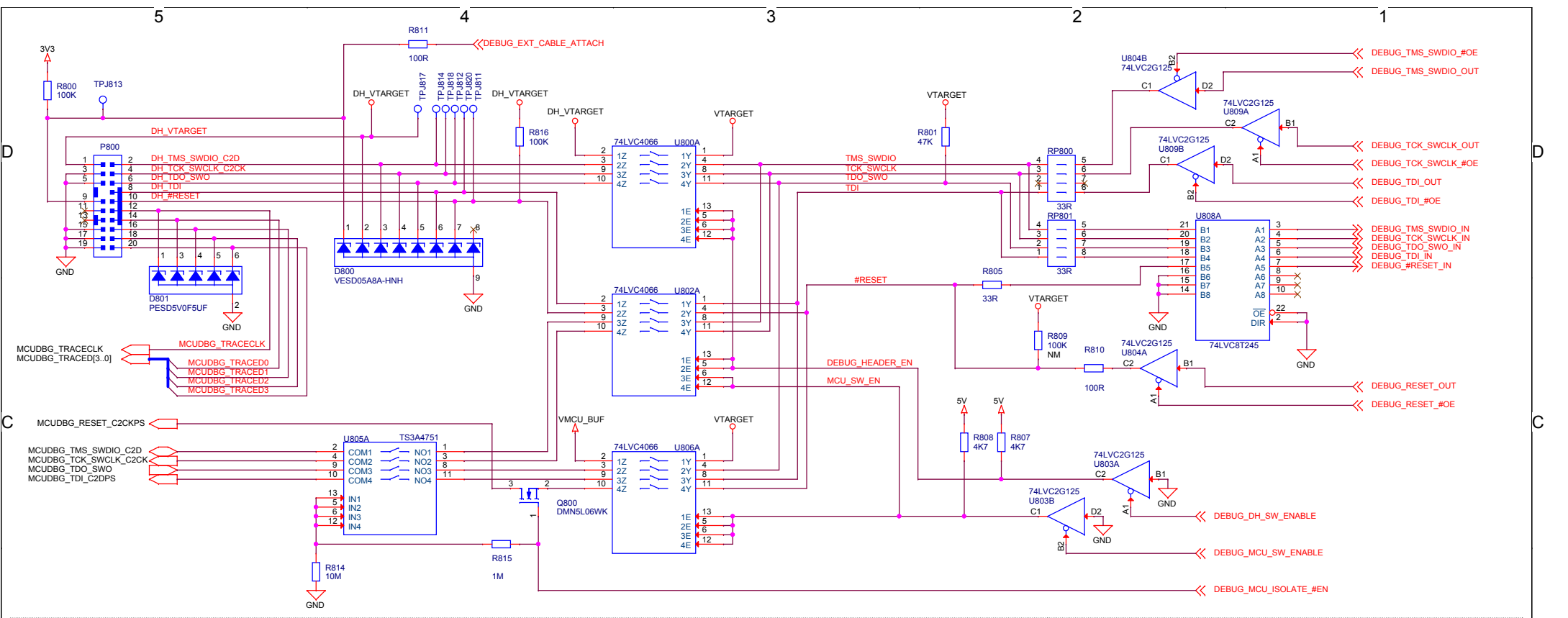

Mode	DEBUG_MCU_SW_ENABLE	DEBUG_DH_SW_ENABLE	DEBUG_BUF_#OE	ISOLATE_#EN	DH_VTARGET	VTARGET
Debug Out	0	1	0	0	External voltage	External voltage
MCU Debug	1	0	0	1	Disconnected	VMCU
Debug In	1	1	1	1	VMCU	VMCU
Debug Off	1	1	1	0	-	-

**/HB1  
MCU STK Platform**

**SILICON LABS**

Designed: DDB | Approved: JNO  
Size: A3 | BOM Doc No: <Cage Code>  
Design Created Date: Monday, May 12, 2014

<b>Schematic Title</b>		
<b>EFM32PG12 Pearl Gecko Starter Kit</b>		
<b>Page Title</b>		
<b>Debug Interface</b>		
<b>Document number</b>		<b>Revision</b>
<b>BRD2501A</b>		<b>A00</b>
<b>Sheet Created Date</b>	<b>Sheet Modified Date</b>	<b>Sheet</b>
Monday, May 12, 2014	Thursday, December 15, 2016	8 of 10



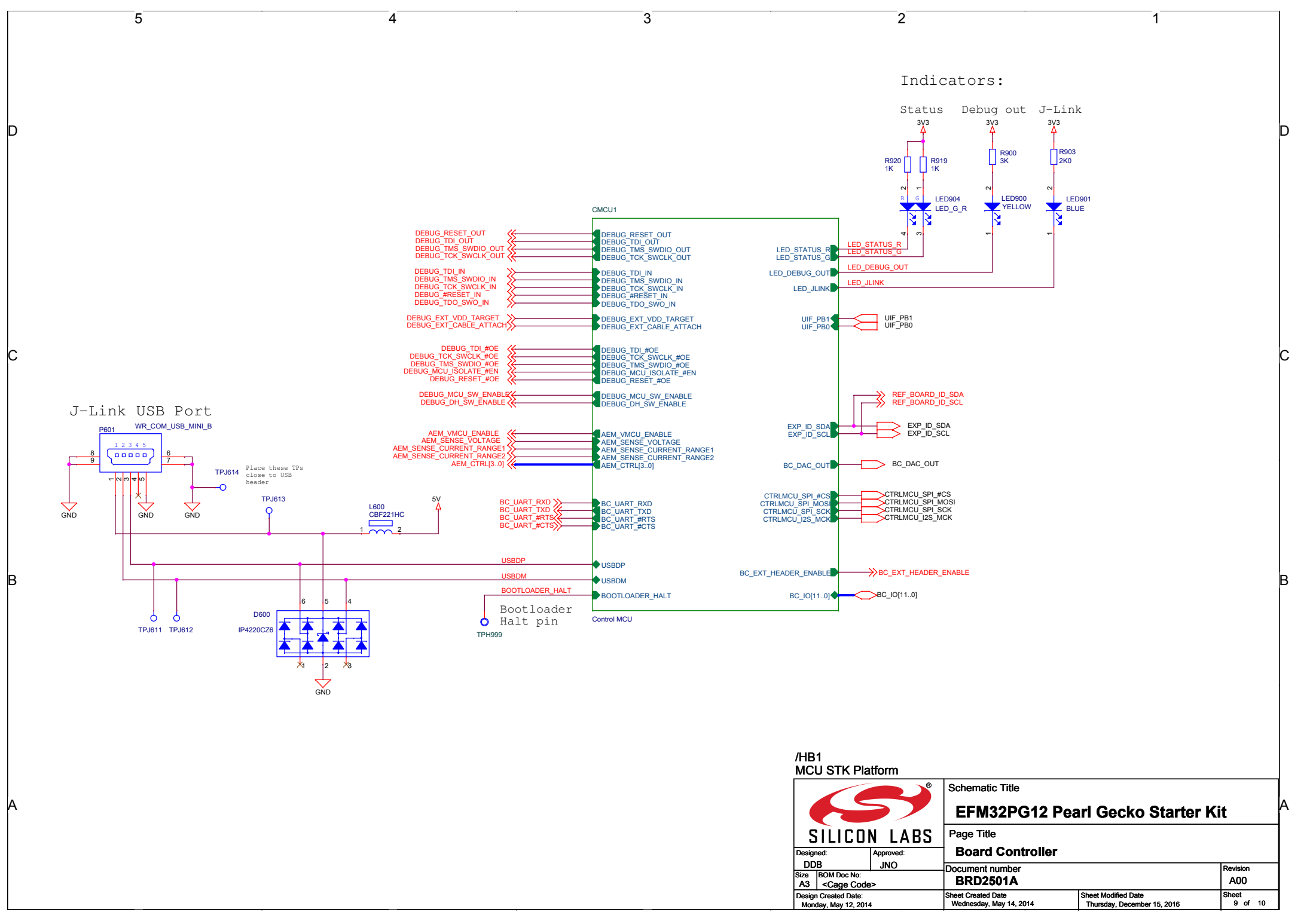

Indicators:

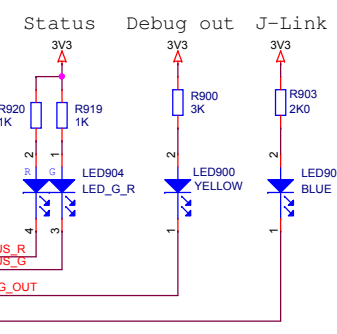

/HB1  
MCU STK Platform

 <b>SILICON LABS</b>		Schematic Title	
		<b>EFM32PG12 Pearl Gecko Starter Kit</b>	
Designed: DDB Approved: JNO		Page Title	
		<b>Board Controller</b>	
Size: A3	BOM Doc No: <Cage Code>	Document number	Revision
Design Created Date: Monday, May 12, 2014		<b>BRD2501A</b>	A00
Sheet Created Date: Wednesday, May 14, 2014		Sheet Modified Date: Thursday, December 15, 2016	Sheet 9 of 10

# Virtual COM Port Interface

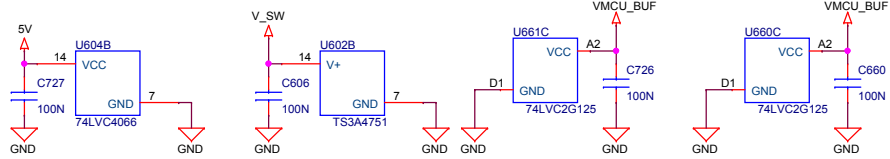
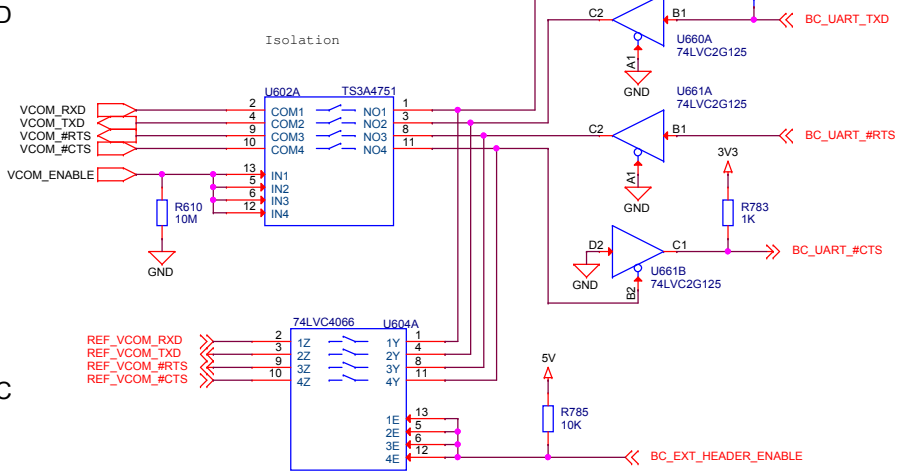

# Connector for external reference designs boards

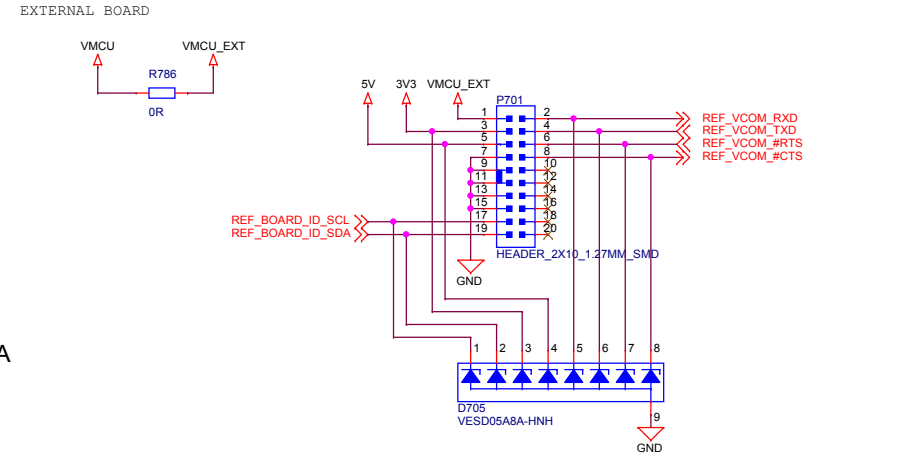

# 3V3 Regulator

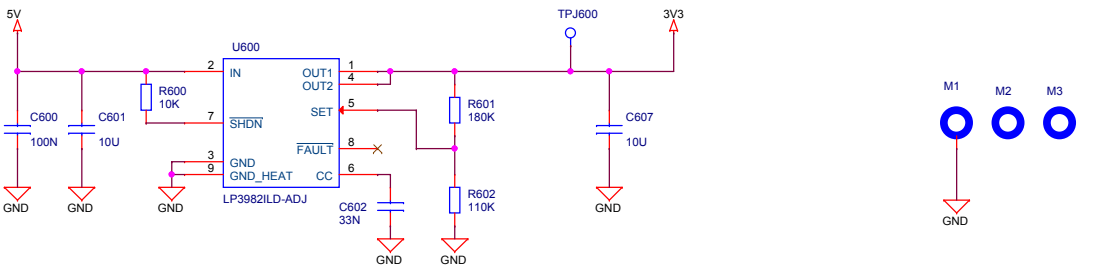

# VMCU Voltage Mirror

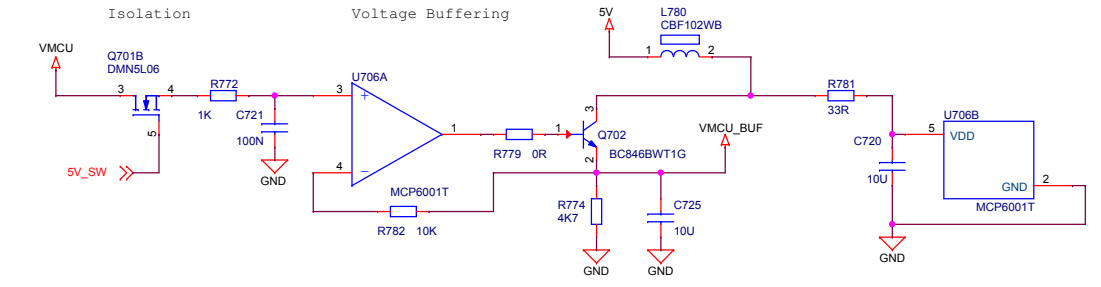

# Power Supply for Analog Switches

The USB VBUS voltage is used to bias these transistors, turning the P-Channel MOSFETs (Q700) off, and the N-Channel MOSFETs (Q701) on.

J-Link USB Cable	PMOS State	NMOS State	V_SW	VMCU_SENSE
Connected	Off	ON	3.6V	VMCU
Disconnected	ON	OFF	VMCU	Isolated

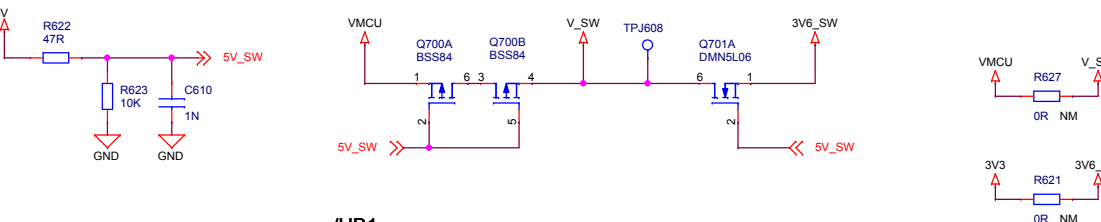
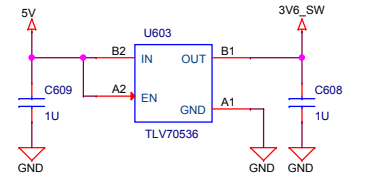

**/HB1 MCU STK Platform**

**Schematic Title**  
**EFM32PG12 Pearl Gecko Starter Kit**

**Page Title**  
**Power & Misc**

**Document number**  
**BRD2501A**

**Revision**  
**A00**

**Designed:** DDB **Approved:** JNO

**Size:** A3 **BOM Doc No:** <Cage Code>

**Design Created Date:** Monday, May 12, 2014 **Sheet Created Date:** Monday, May 12, 2014 **Sheet Modified Date:** Thursday, December 15, 2016 **Sheet** 10 of 10

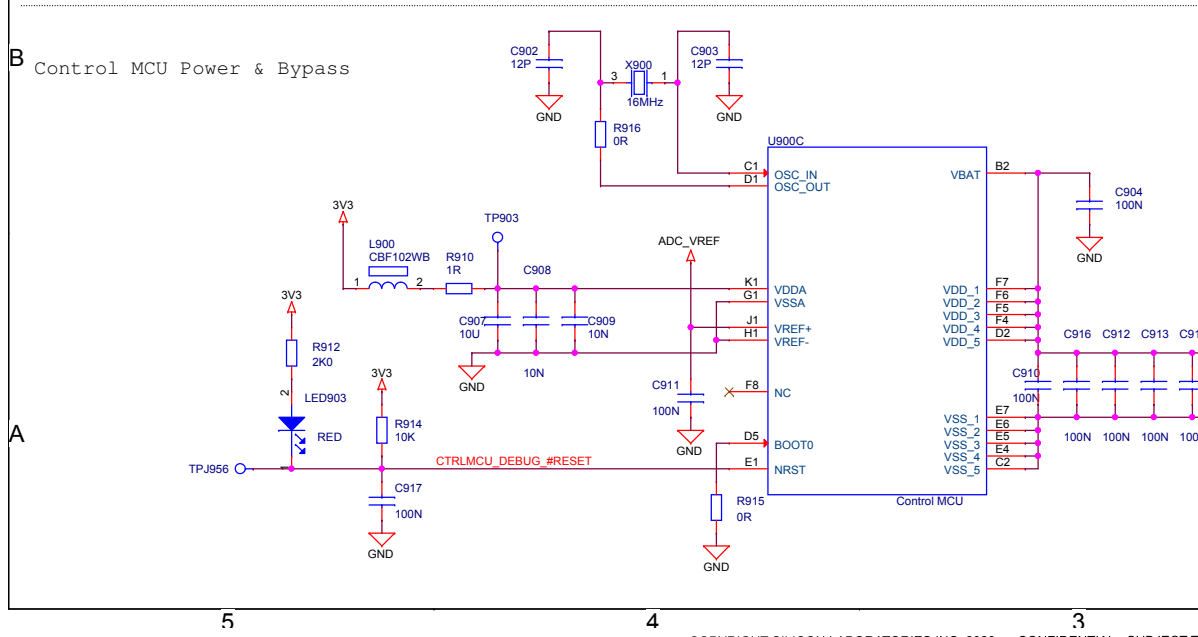
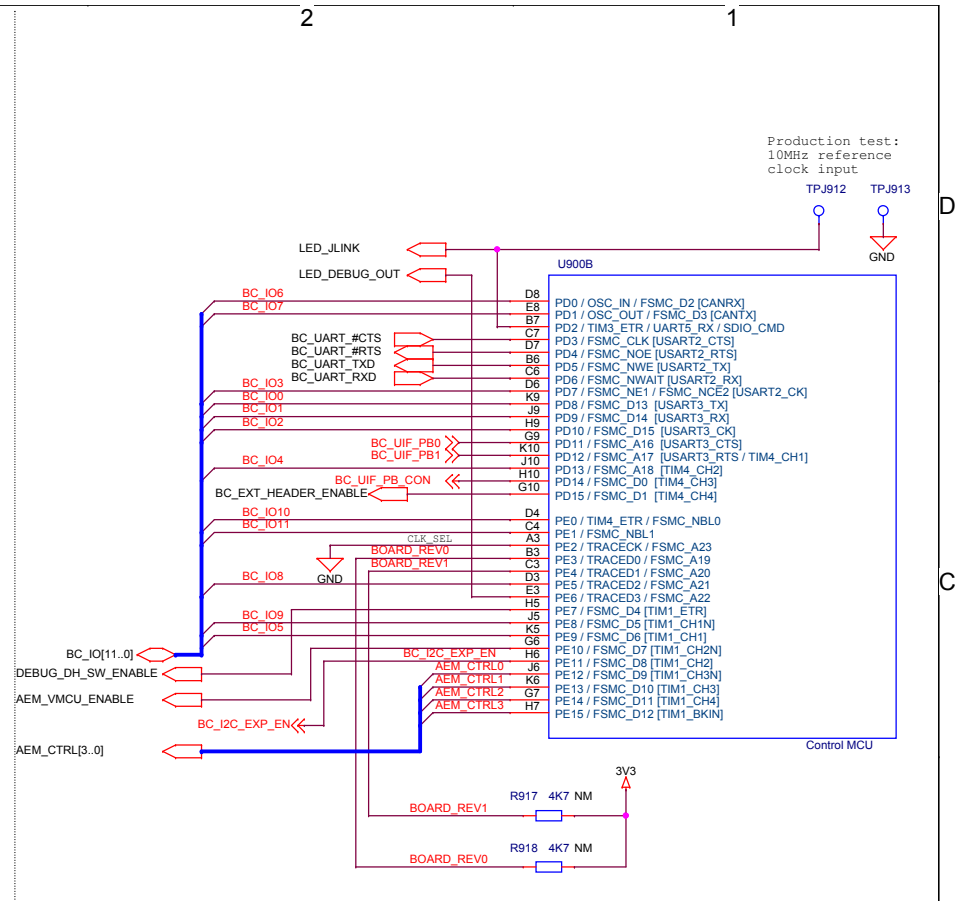
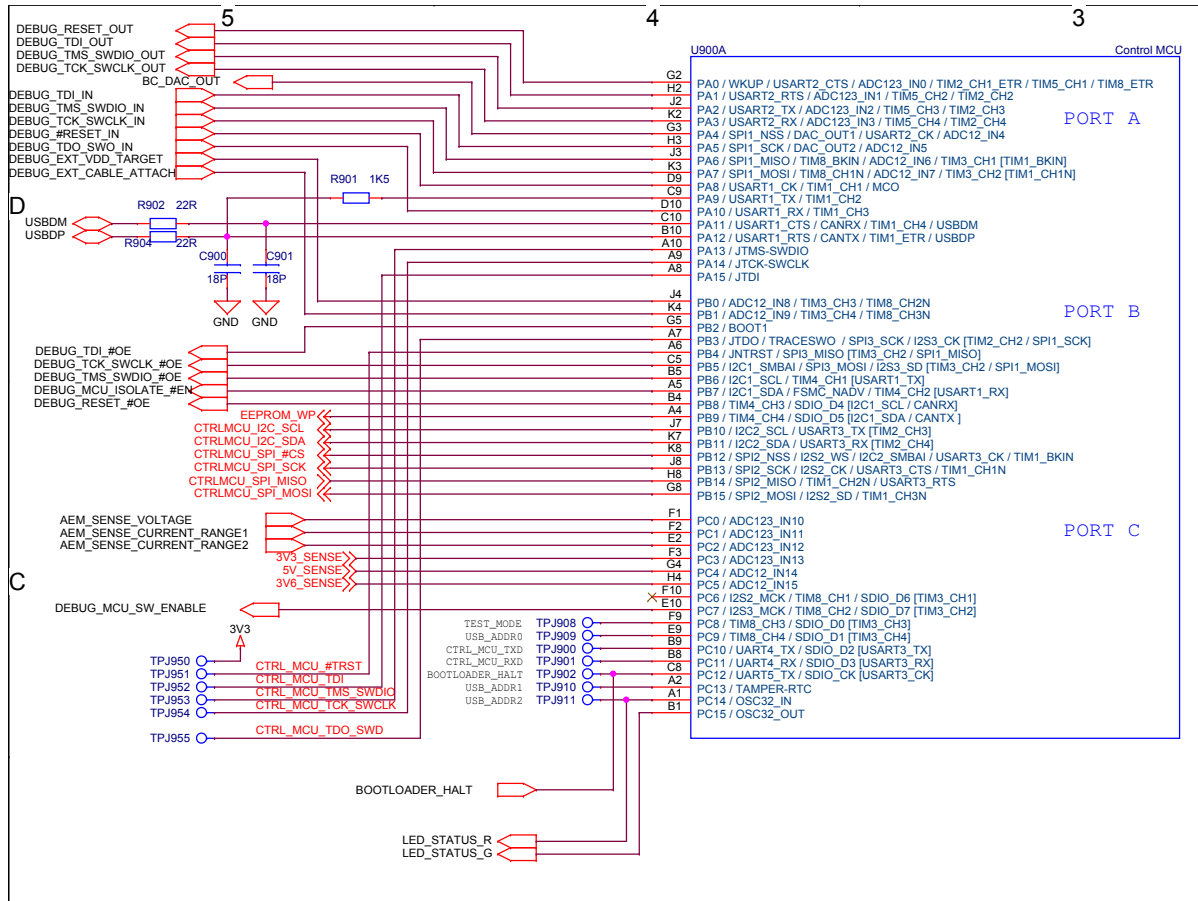

**/HB1/CMCU1 Control MCU**

		Schematic Title	
		<b>EFM32PG12 Pearl Gecko Starter Kit</b>	
Designed: DDB Approved: JNO		Page Title	
		<b>Control MCU</b>	
Size: A3	BOM Doc No: <Cage Code>	Document number	Revision
Design Created Date: Monday, May 12, 2014		<b>BRD2501A</b>	<b>A00</b>
Sheet Created Date: Wednesday, February 11, 2015	Sheet Modified Date: Wednesday, October 12, 2016	Sheet 11 of 10	

### ADC reference voltage

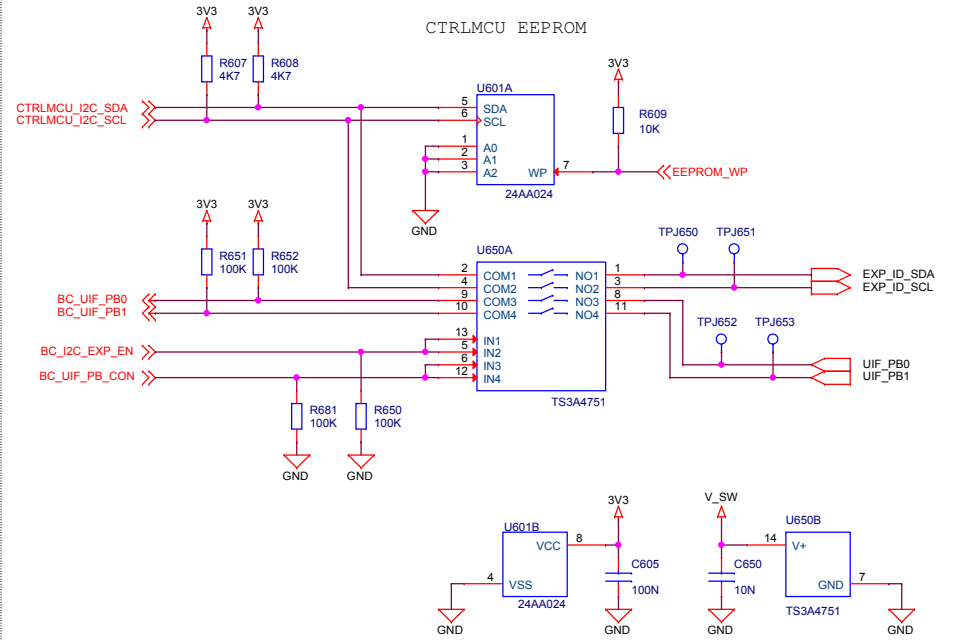
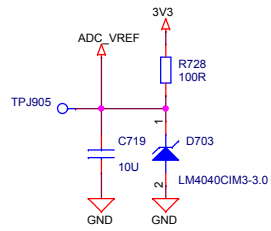

### CTRLMCU SERIAL FLASH

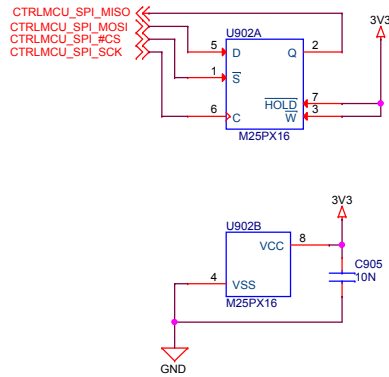

### POWER SENSE

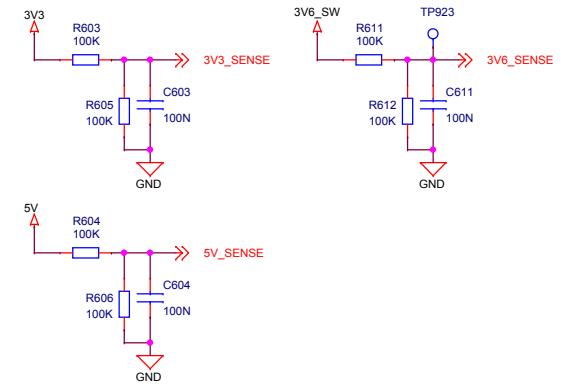

/HB1/CMCU1  
Control MCU

 <b>SILICON LABS</b>		Schematic Title	
		<b>EFM32PG12 Pearl Gecko Starter Kit</b>	
Designed: DDB Approved: JNO		Page Title	
		<b>Board Controller Misc</b>	
Size: A3 BOM Doc No: <Cage Code>		Document number <b>BRD2501A</b>	
Design Created Date: Monday, May 12, 2014		Sheet Created Date Wednesday, February 11, 2015	Sheet Modified Date Friday, October 14, 2016
		Revision	Sheet 12 of 10