



Wireless STK Mainboard	
Board Function	Page
Title Page	1
User Interface	2
Radio Board Interface	3
Breakout Signals	4
Target Voltage Supply	5
Target Supply Control	6
Advanced Energy Monitor	7
Debug Multiplexer	8
Board Voltage Supply	9
VCOM & PTI Multiplexer	10
Logic Analyzer & Mini Simplicity Connector	11
Board Controller IO	12 13
Board Controller Power	14
Board Controller Misc.	15
Board Controller USB & Ethernet	16

Revision History	
Rev.	Description
A00	Initial production release
A01	Removed U720 Opamp, changed to KLS Ethernet jack
A02	Changed to discrete current sense amplifier, 0.5 ohm sense resistor
A03	Discrete LDO, improved logic analyzer front end



<Schematic Path>  
WSTK

<p><b>SILICON LABS</b></p>		Schematic Title	
		<b>Wireless Starter Kit Platform</b>	
Designed: HEL Approved: RGU		Page Title	
		<b>Title Page</b>	
Size A3	BOM Doc No: <Cage Code>	Document number <b>BRD4002A</b>	Revision A03
Design Created Date: Wednesday, December 03, 2008		Sheet Created Date Saturday, March 21, 2009	Sheet Modified Date Wednesday, June 02, 2021
		Sheet 1 of 16	

### Memory LCD-TFT Display & Multiplexer

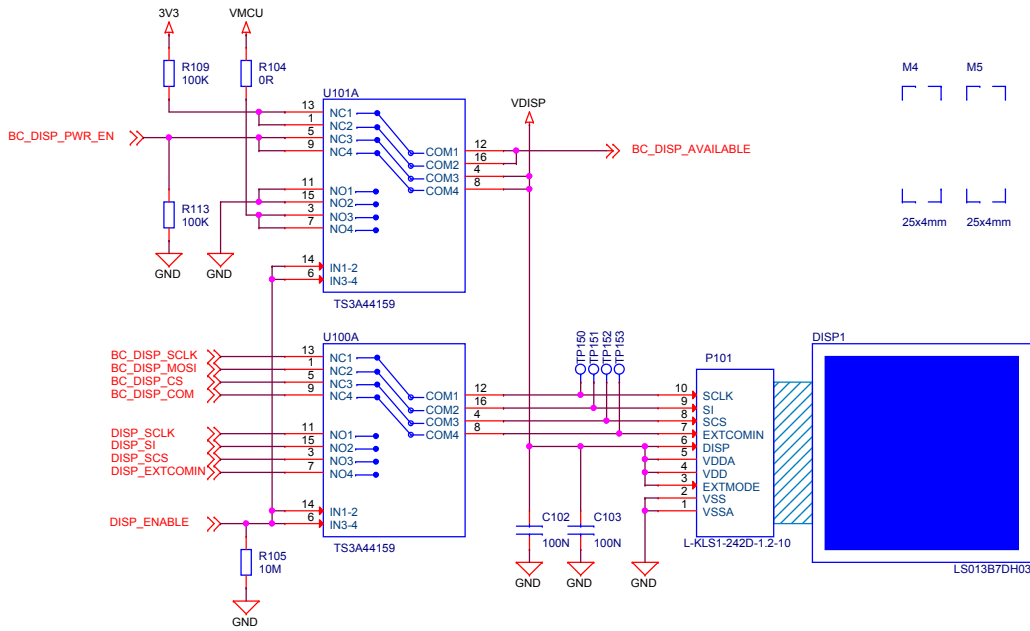

DISP_ENABLE	Connected	V_DISP	BC_DISP_AVAILABLE
1	RADIO	VMCU	GND
0	BC	BC_DISP_PWR_EN	3V3

The target device always controls ownership of the display using the DISP\_ENABLE signal

### Relative Humidity & Temperature Sensor

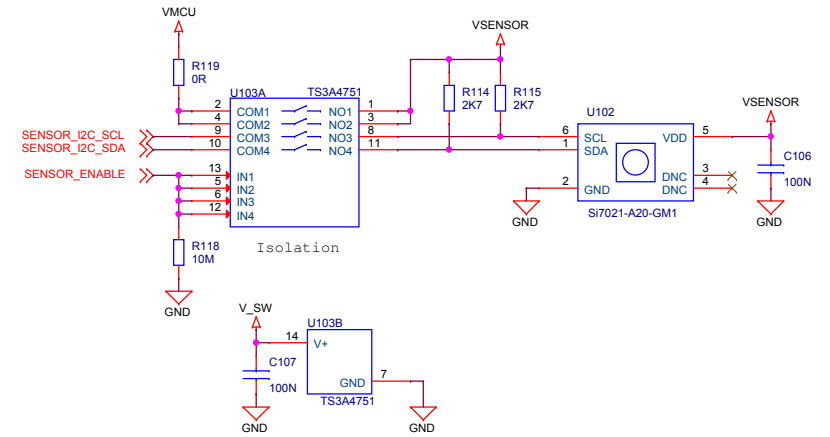

### Analog Joystick

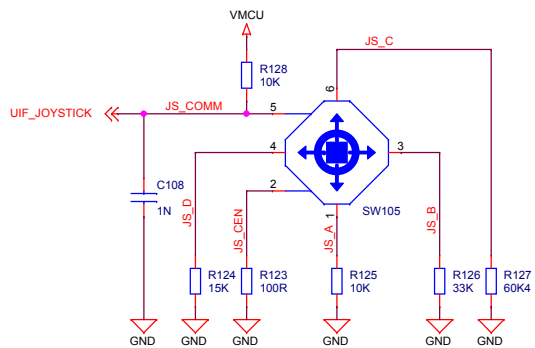

### User pushbuttons

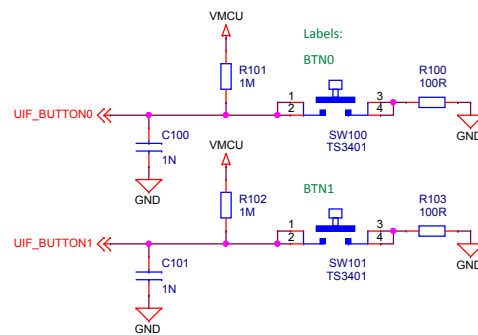

### User LEDs

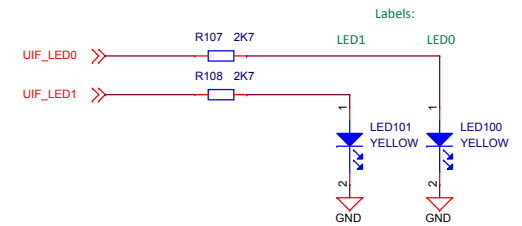

<Schematic Path>  
WSTK

		Schematic Title	
		<b>Wireless Starter Kit Platform</b>	
Designed: HEL Approved: RGU		Page Title	
		<b>User Interface</b>	
Size A3	BOM Doc No: <Cage Code>	Document number <b>BRD4002A</b>	Revision A03
Design Created Date: Wednesday, December 03, 2008		Sheet Created Date: Thursday, October 06, 2016	Sheet Modified Date: Wednesday, June 02, 2021
		Sheet 2 of 16	

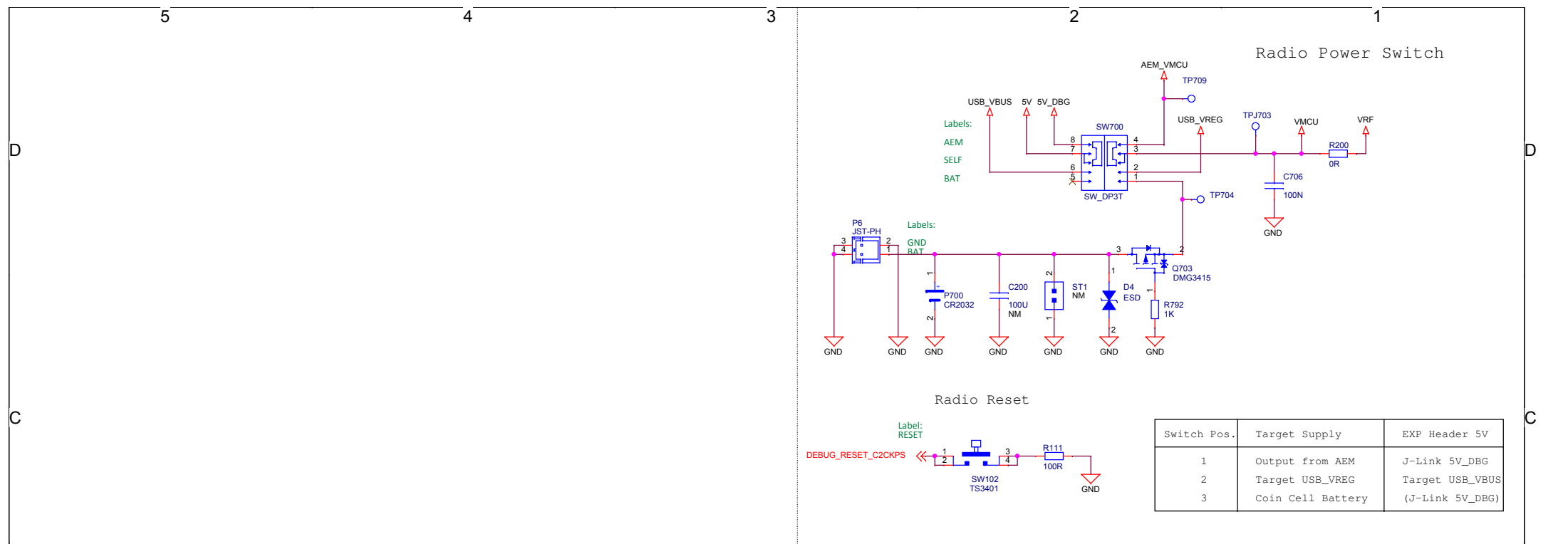

Radio Board Connectors

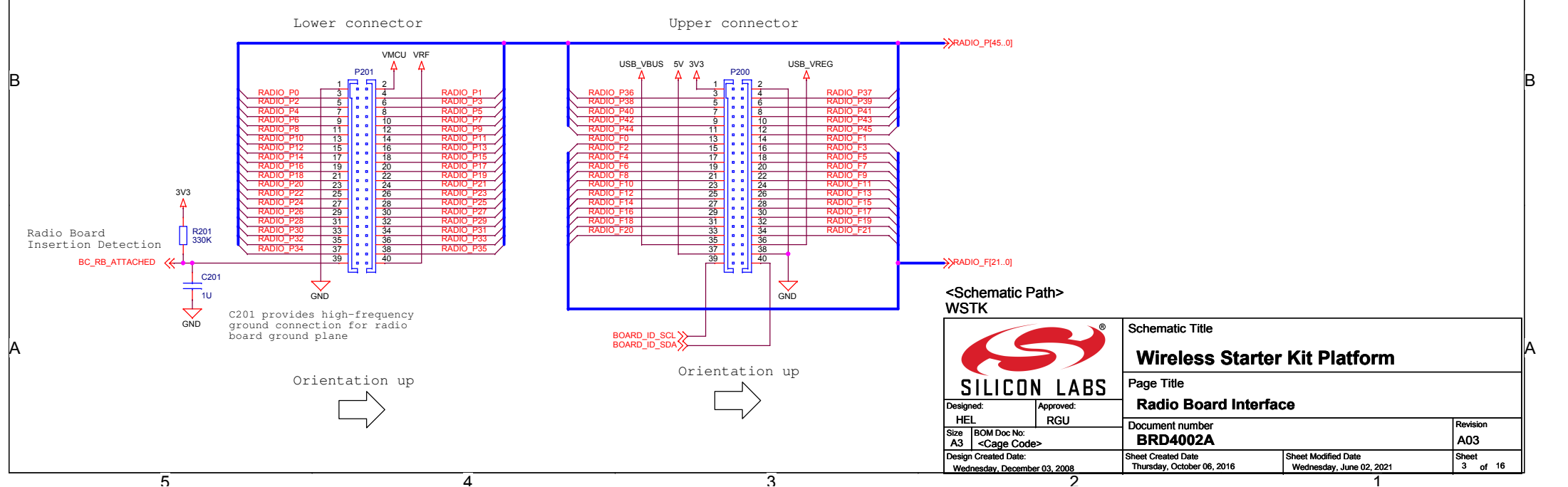

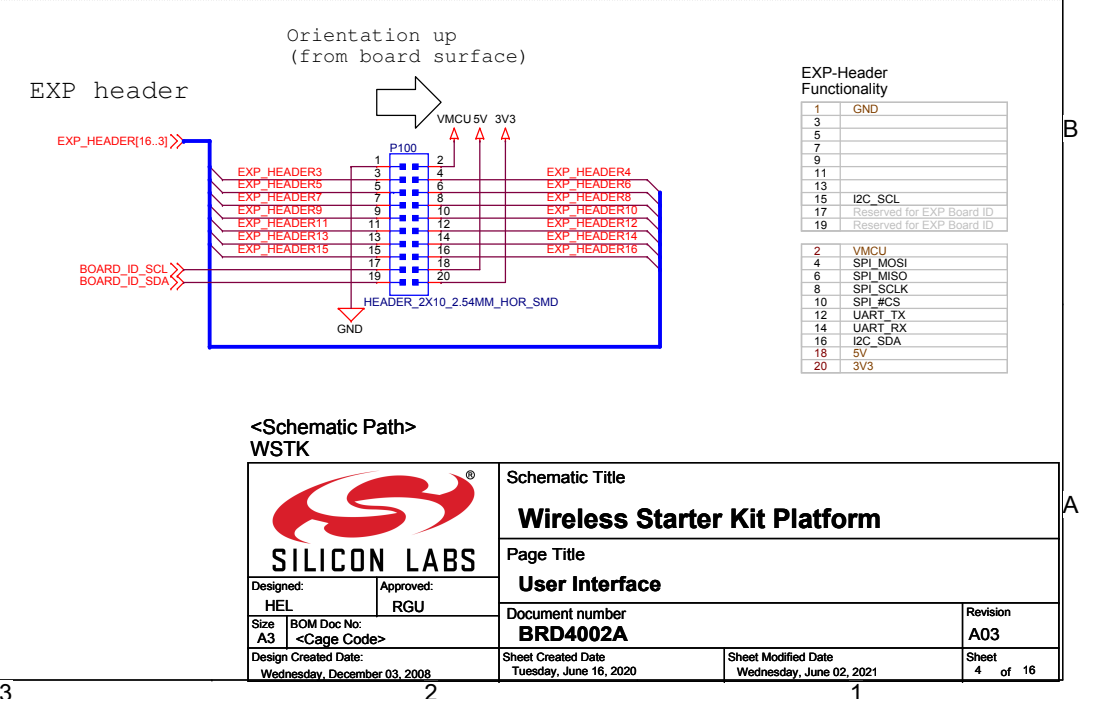
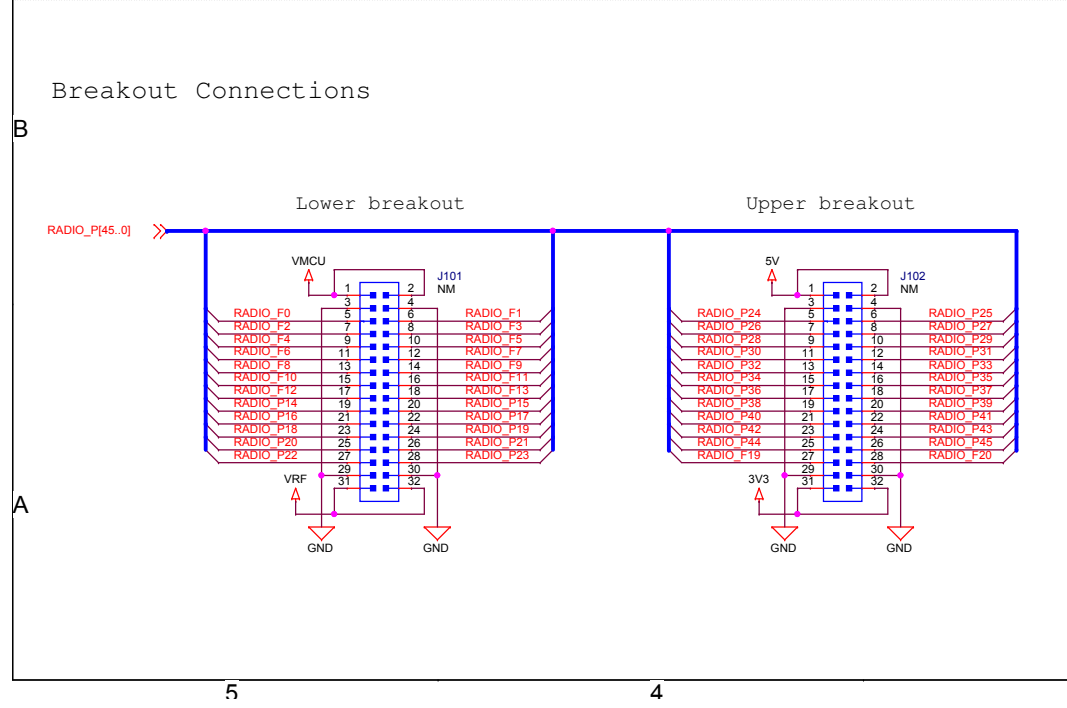
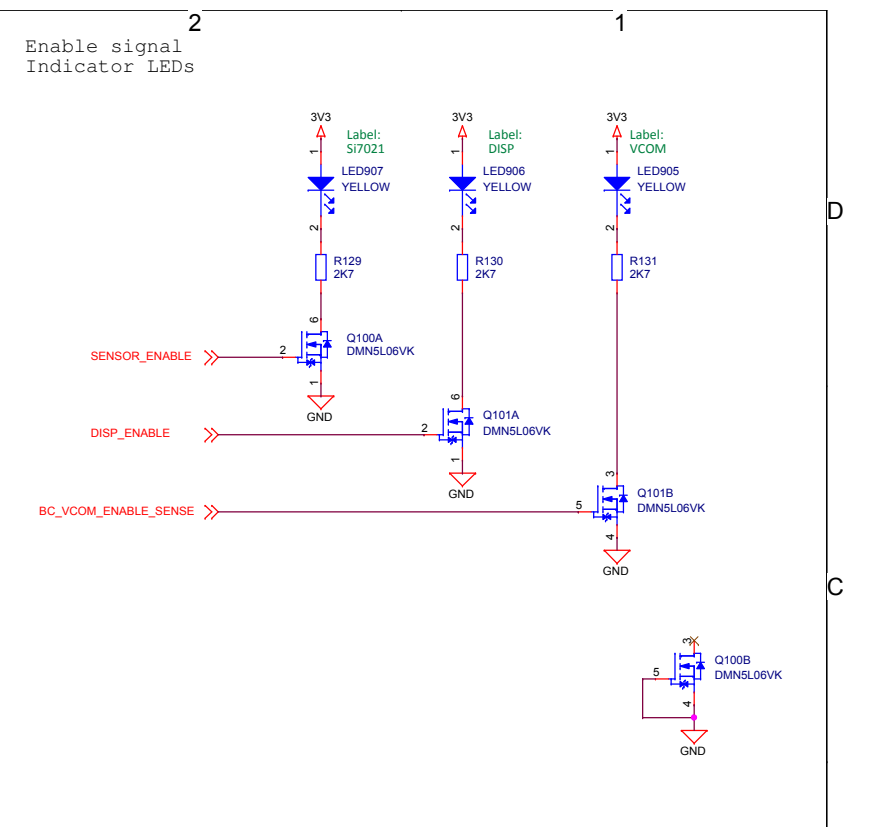
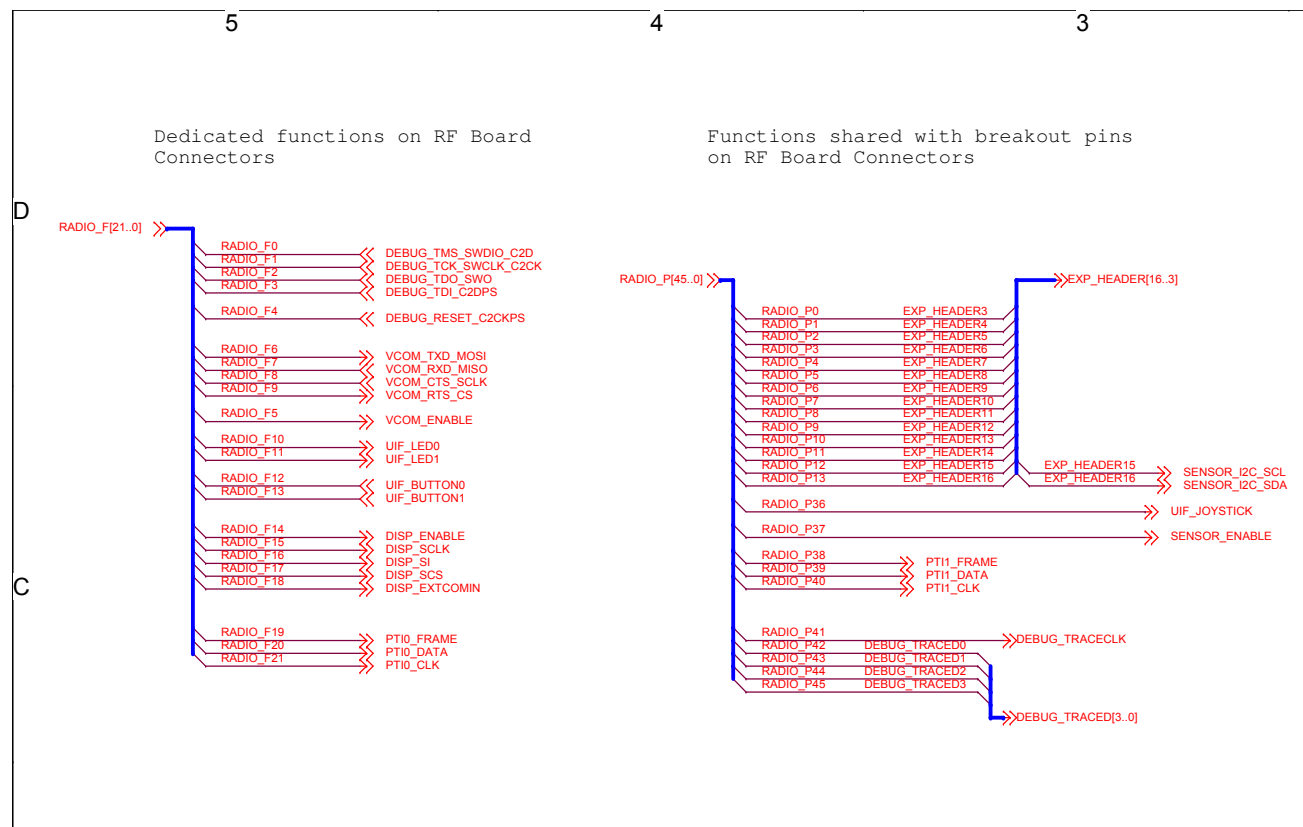

### 3V3 Regulator

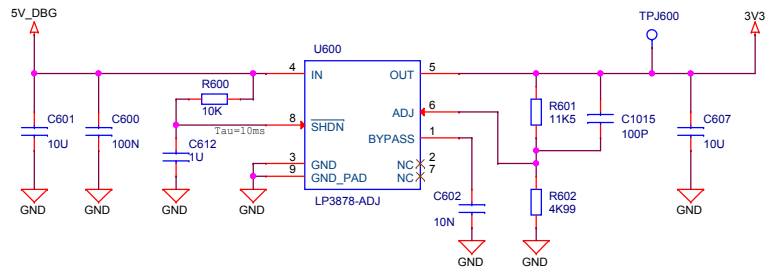

### VTarget Voltage Mirror

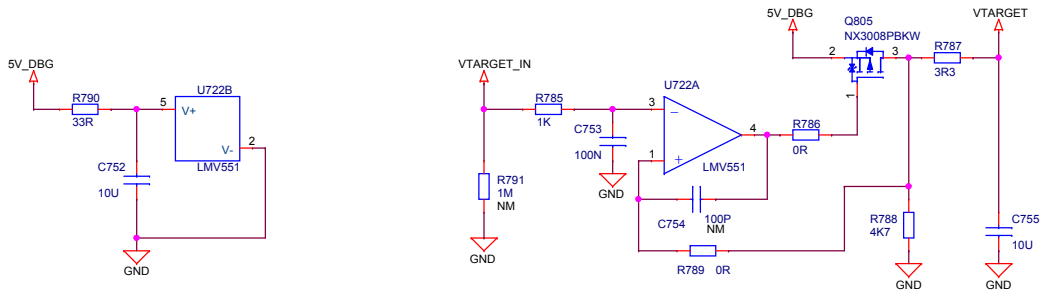

### VMCU Voltage Mirror

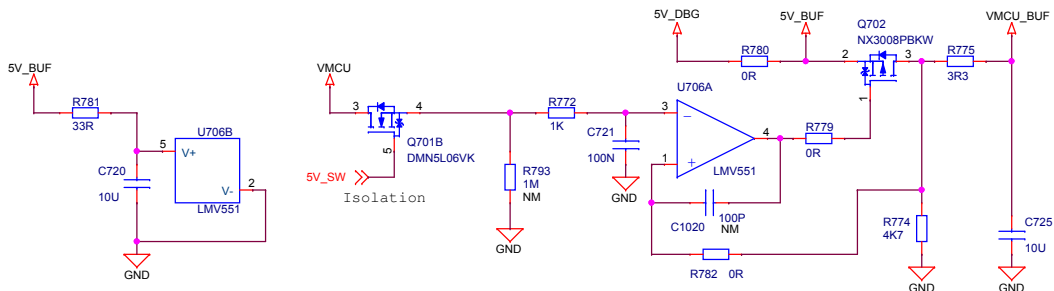

### Power Supply for Analog Switches

Analog switches used for isolation are powered by 3V6\_SW when the USB cable is connected, otherwise by VMCU.

J-Link USB Cable	PMOS State	NMOS State	V_SW	VMCU_SENSE
Connected	Off	ON	3.6V	VMCU
Disconnected	ON	OFF	VMCU	Isolated

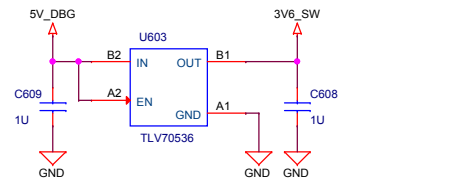
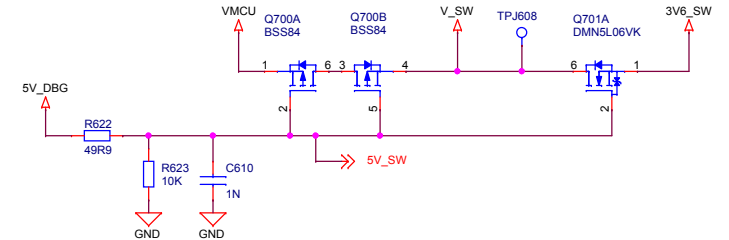

### Buffered voltage monitoring

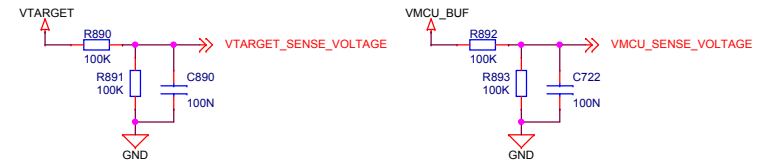

Mode	VTARGET SOURCE	VTREF SOURCE
Debug Out	VTREF (EXT)	NONE (SELF)
Mini Out	VMCU	NONE
MCU Debug	VMCU	NONE
Debug In	VMCU	VMCU_BUF
Debug Off	VMCU	NONE

WSTK

		Schematic Title	
		<b>Wireless Starter Kit Platform</b>	
Designed: HEL Size: A3 Design Created Date: Wednesday, December 03, 2008		Page Title	
		<b>Voltage Regulators</b>	
Approved: RGU BOM Doc No: <Cage Code>		Document number	
		<b>BRD4002A</b>	
Revision		Revision	
A03		A03	
Sheet Created Date		Sheet Modified Date	
Monday, March 23, 2020		Wednesday, June 02, 2021	
Sheet 8 of 16		Sheet 8 of 16	

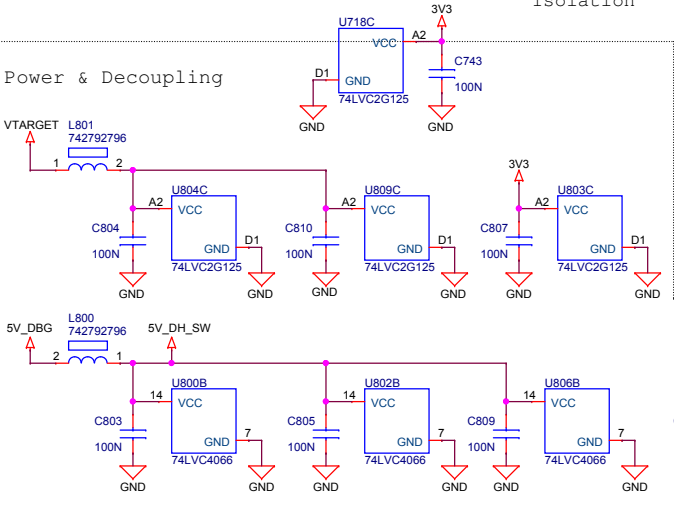
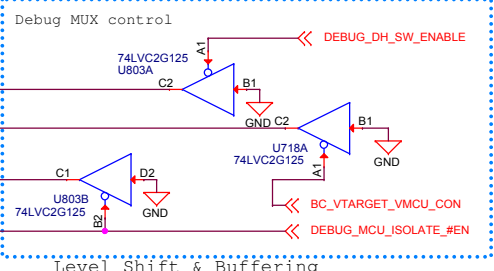
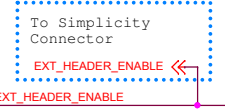
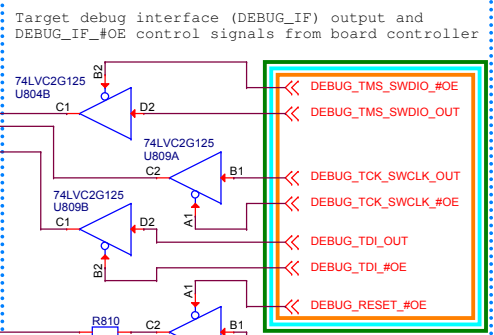
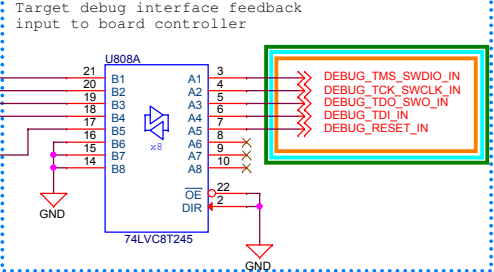
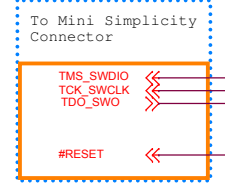
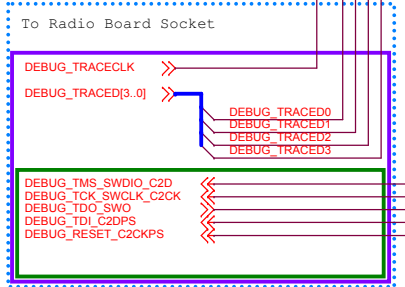
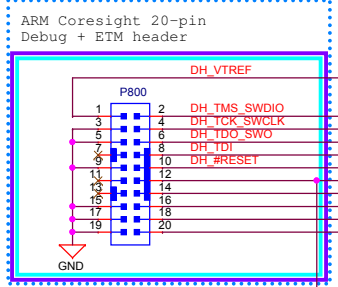

Mode	VTARGET_VMCU_CON	DEBUG_DH_SW_ENABLE	MINI_SW_ENABLE	DEBUG_IF_#OE	ISOLATE_#EN	VTREF	VTARGET
Debug Out	0	1	0	0/1	0	External voltage	External voltage
Mini Out	1	0	1	0/1	0	Disconnected	VMCU
MCU Debug	1	0	0	0/1	1	Disconnected	VMCU
Debug In	1	1	0	1	1	VMCU	VMCU
Debug Off	1	0	0	1	0	-	-

Color coded frames indicates which groups of signal nodes that are active in a given debug mode

<Schematic Path>  
WSTK

Designed: HEL  
Approved: RGU  
Size: A3  
BOM Doc No: <Cage Code>  
Design Created Date: Wednesday, December 03, 2008

Schematic Title		<b>Wireless Starter Kit Platform</b>	
Page Title		<b>Debug Interface</b>	
Document number	<b>BRD4002A</b>	Revision	<b>A03</b>
Sheet Created Date	Monday, March 23, 2020	Sheet Modified Date	Wednesday, June 02, 2021
Sheet 9 of 16			

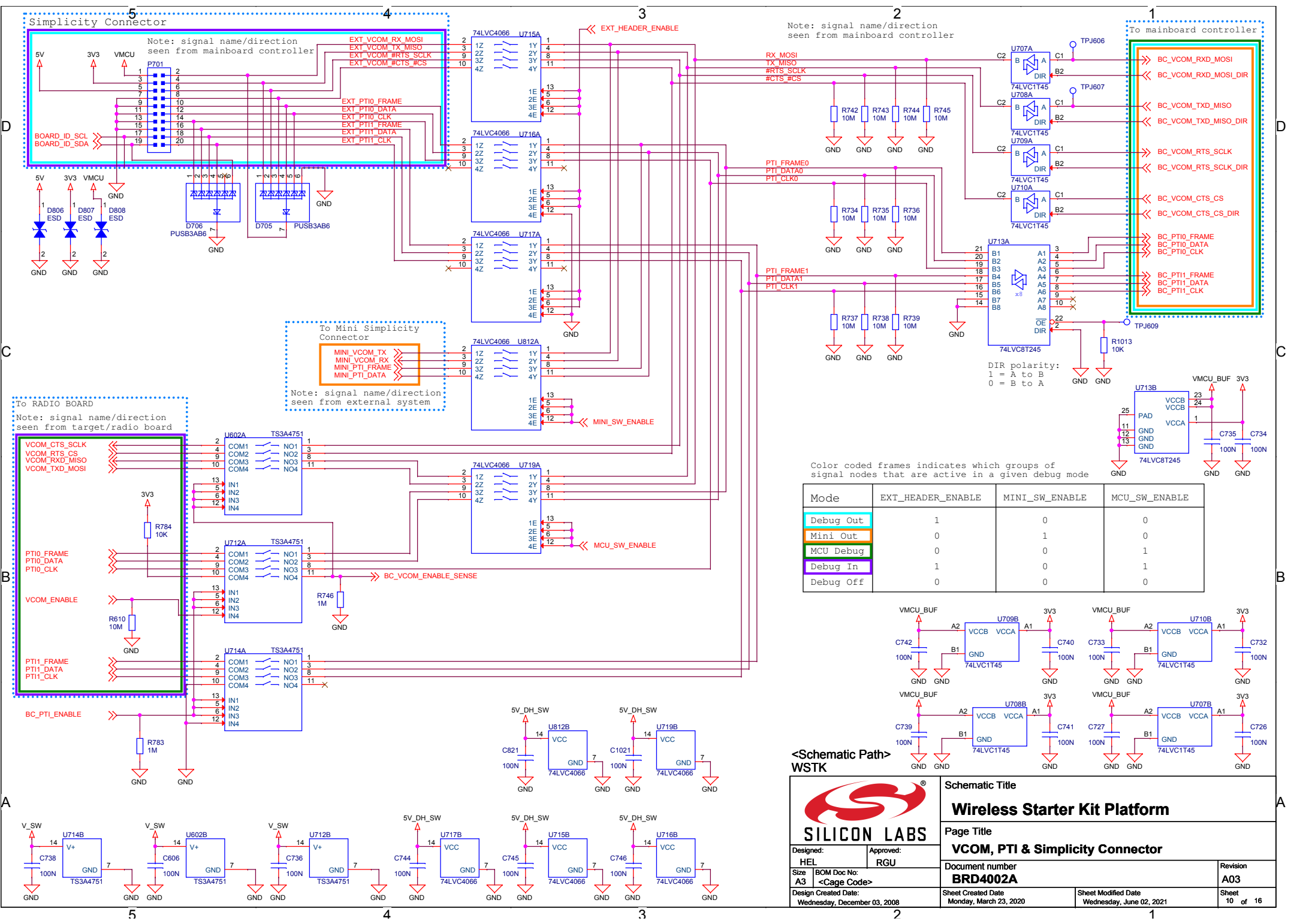

Mode	EXT_HEADER_ENABLE	MINI_SW_ENABLE	MCU_SW_ENABLE
Debug Out	1	0	0
Mini Out	0	1	0
MCU Debug	0	0	1
Debug In	1	0	1
Debug Off	0	0	0

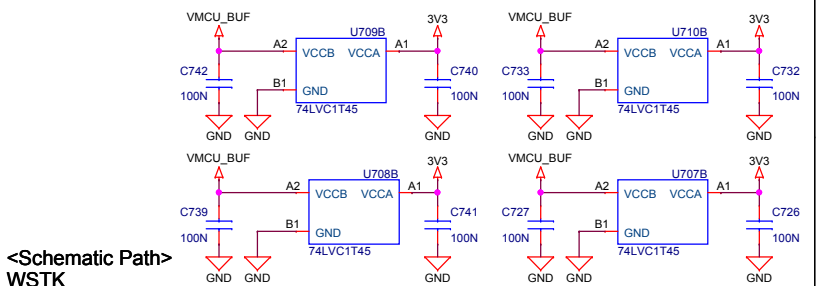

**<Schematic Path>**  
WSTK

**Schematic Title**  
**Wireless Starter Kit Platform**

**Page Title**  
**VCOM, PTI & Simplicity Connector**

Designed: HEL Approved: RGU

Size: A3 BOM Doc No: <Cage Code>

Design Created Date: Wednesday, December 03, 2008

Document number  
**BRD4002A**

Sheet Created Date: Monday, March 23, 2020

Sheet Modified Date: Wednesday, June 02, 2021

Revision  
**A03**

Sheet 10 of 16

# Logic Analyzer front end

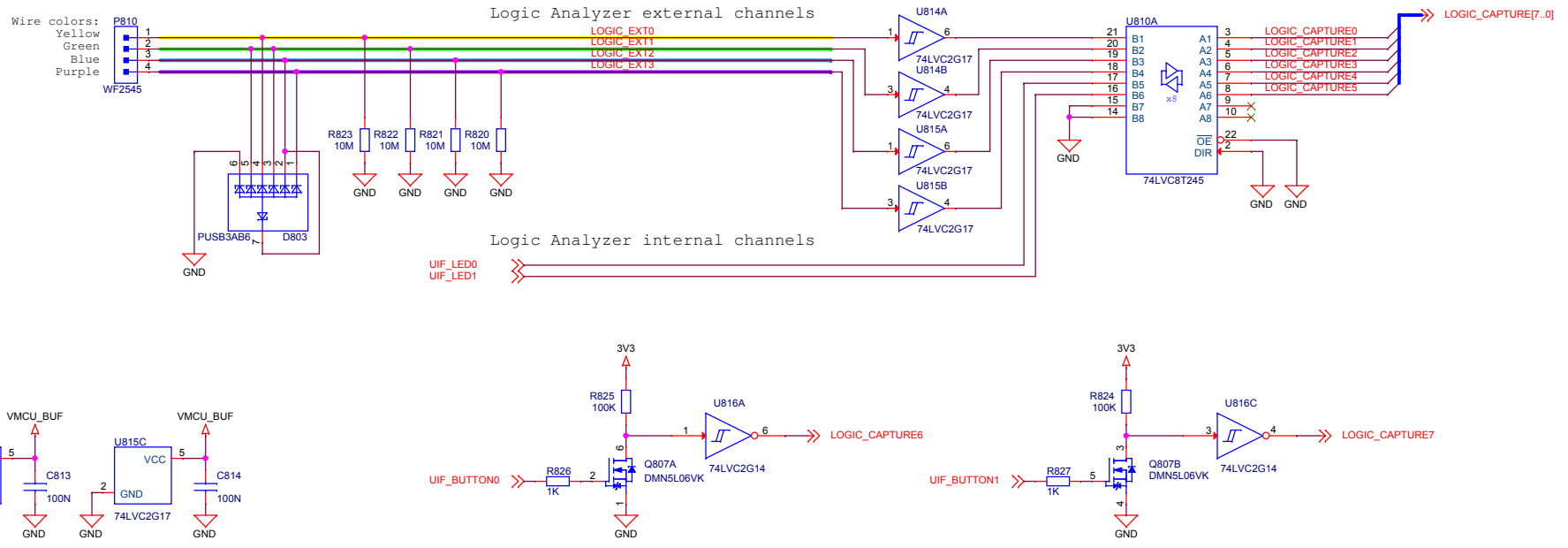

# Mini Simplicity Connector

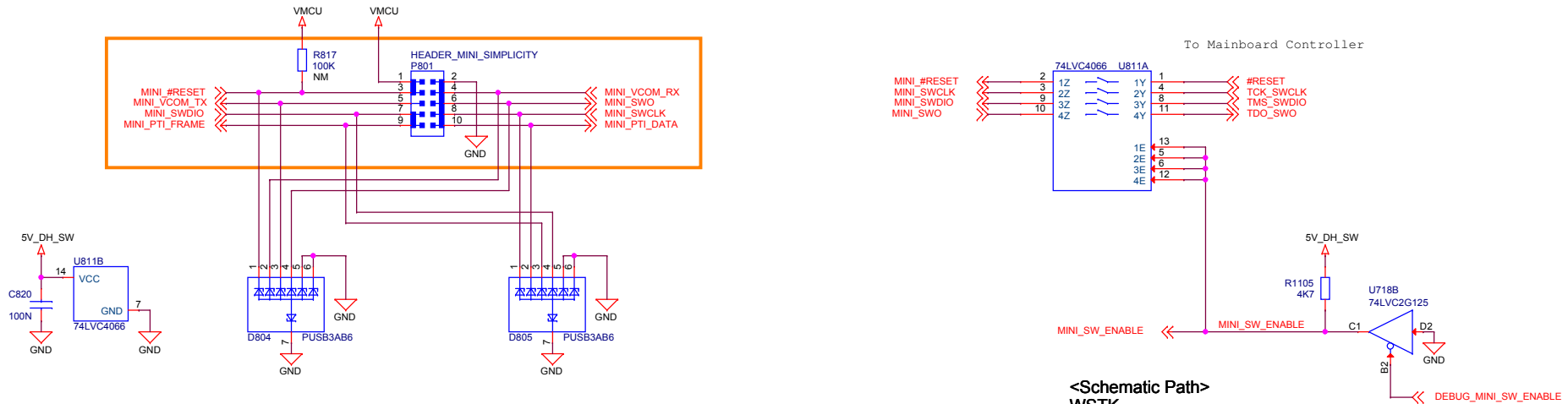

Mode	EXT_HEADER_ENABLE	BC_VCOM_###_DIR	BC_RB_VCOM_#DIS
Debug Out	1	0/1	0
Mini Out	0	0/1	0
MCU Debug	0	0/1	1
Debug In	1	0	1
Debug Off	0	0	0

Color coded frames indicates which groups of signal nodes that are active in a given debug mode

<Schematic Path>  
WSTK

**Schematic Title**  
Wireless Starter Kit Platform

**Page Title**  
Logic Analyzer and Mini Simplicity

Designed: HEL | Approved: RGU

Size: A3 | BOM Doc No: <Cage Code>

Design Created Date: Wednesday, December 03, 2008

Document number: BRD4002A

Sheet Created Date: Monday, March 23, 2020

Sheet Modified Date: Wednesday, June 02, 2021

Revision: A03

Sheet 11 of 16



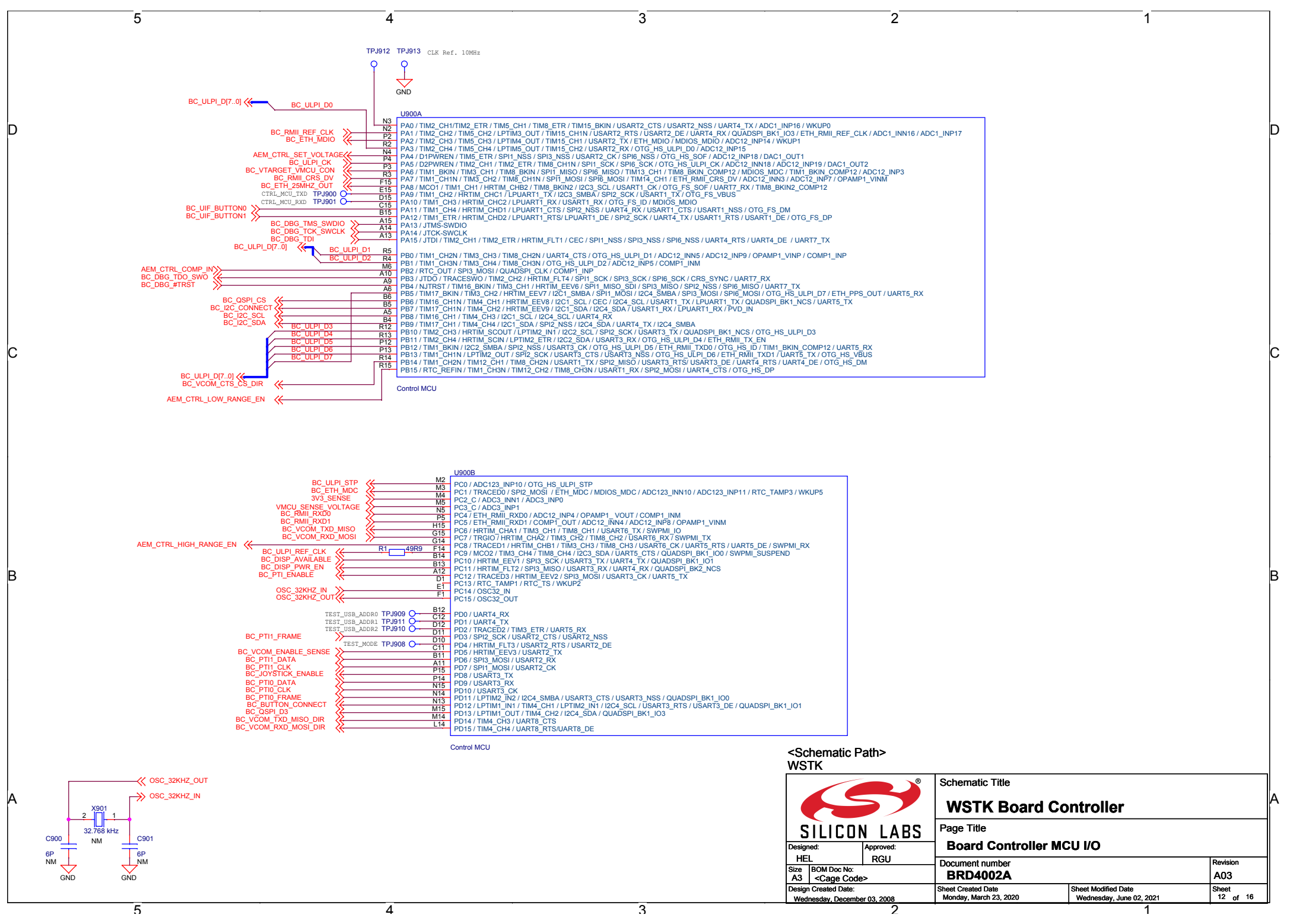

<Schematic Path>  
WSTK

		Schematic Title	
		<b>WSTK Board Controller</b>	
Design: HEL Approved: RGU		Page Title	
		<b>Board Controller MCU I/O</b>	
Size A3	BOM Doc No: <Cage Code>	Document number <b>BRD4002A</b>	Revision A03
Design Created Date: Wednesday, December 03, 2008		Sheet Created Date Monday, March 23, 2020	Sheet Modified Date Wednesday, June 02, 2021
		Sheet 12 of 16	

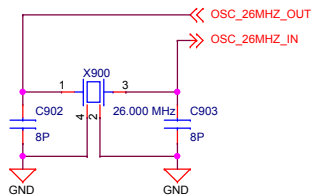
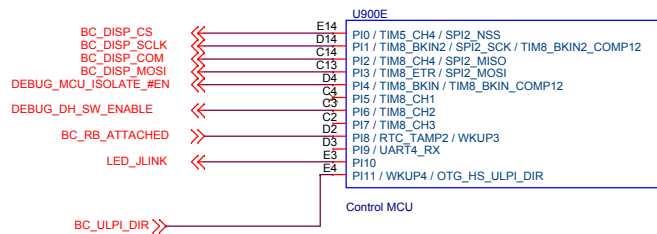
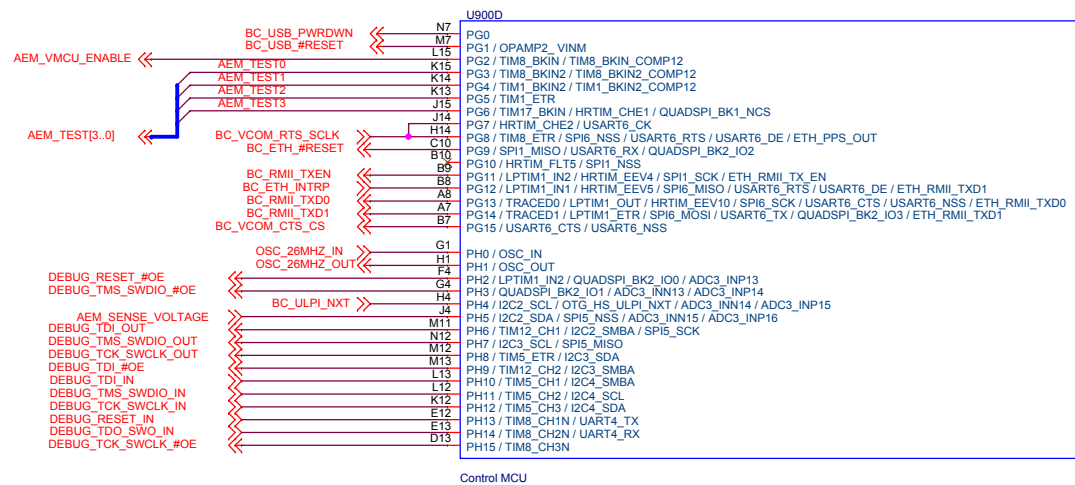
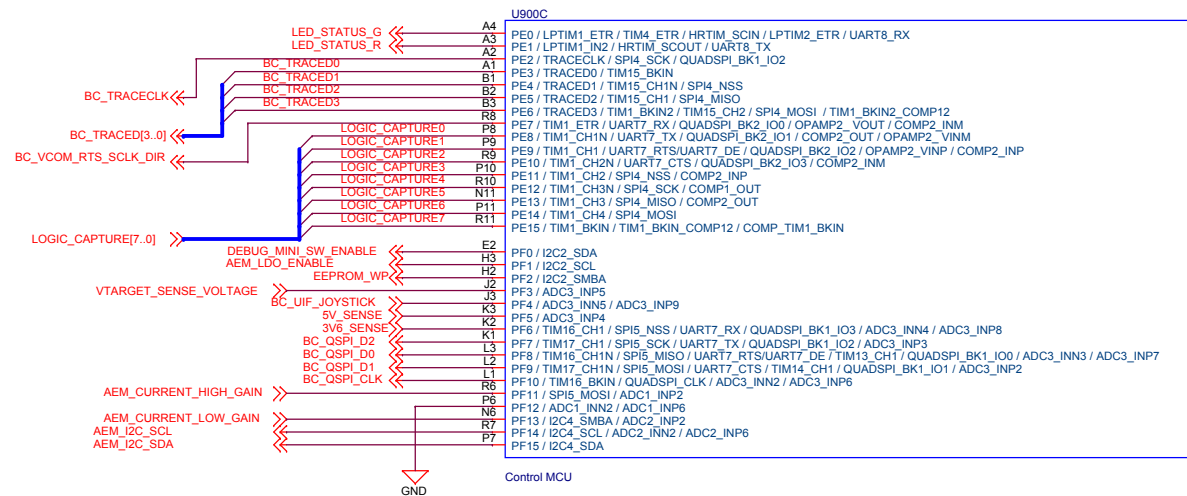

Note: PC13, PC14, PC15 and PI8 have limited current source capabilities

<Schematic Path>  
WSTK

		Schematic Title	
		<b>WSTK Board Controller</b>	
Design: HEL Approved: RGU		Page Title	
		<b>Board Controller MCU I/O</b>	
Size A3	BOM Doc No: <Cage Code>	Document number	
		<b>BRD4002A</b>	
Design Created Date: Wednesday, December 03, 2008	Sheet Created Date Tuesday, July 07, 2020	Sheet Modified Date Wednesday, June 02, 2021	Revision A03 Sheet 13 of 16

Board Controller Power & Decoupling:

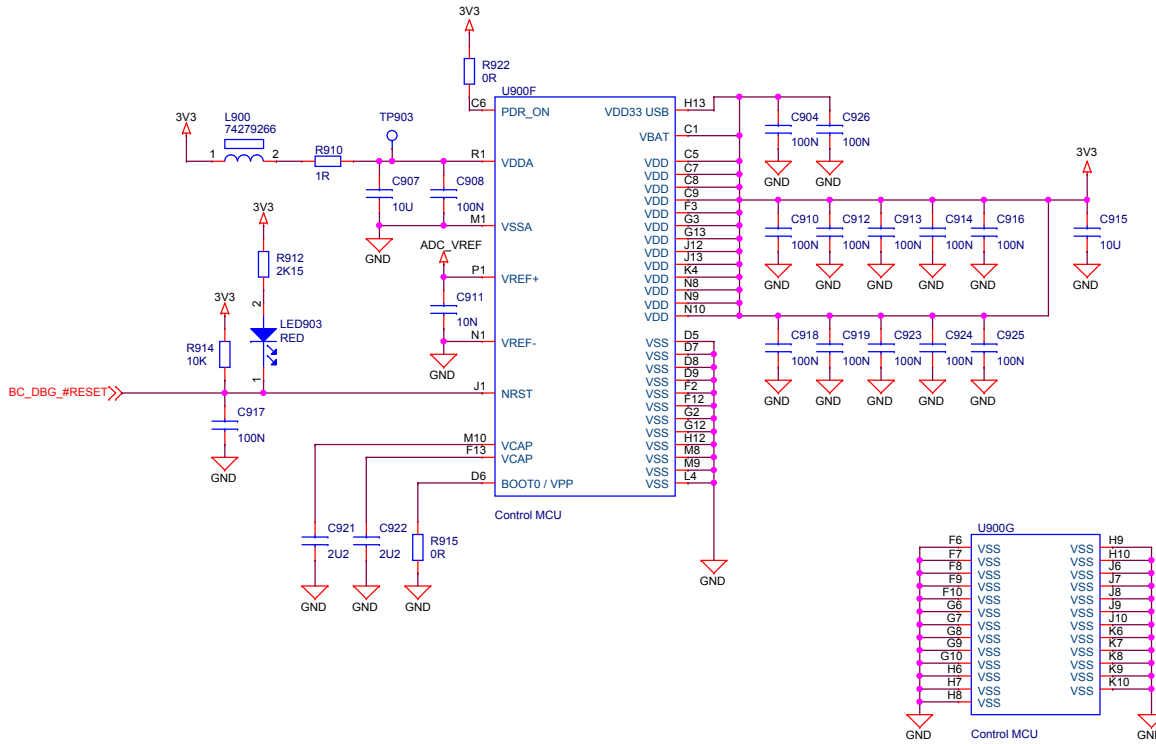

POWER SENSE

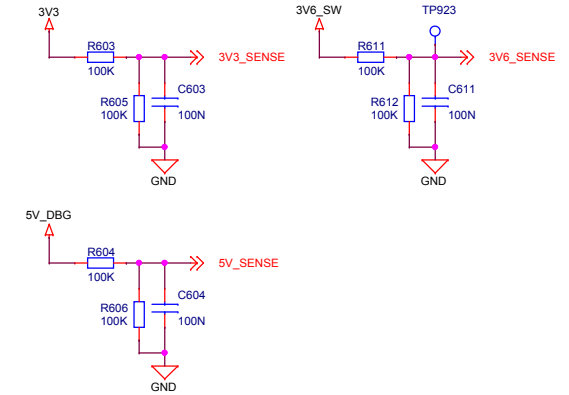

Board Controller Debug & Trace Test Points

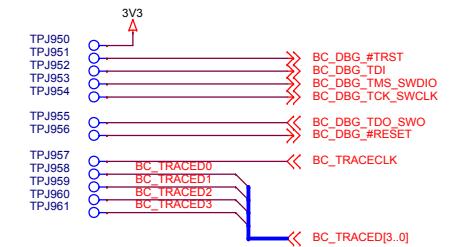

ADC reference voltage

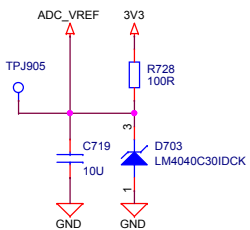

Joystick output buffer

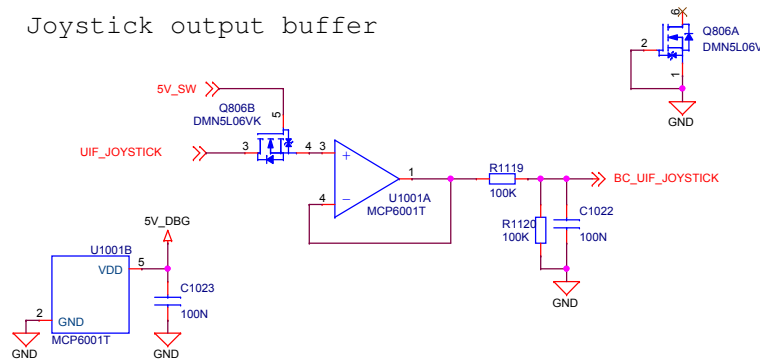

<Schematic Path>  
WSTK

		Schematic Title	
		<b>WSTK Board Controller</b>	
Designed: HEL Size: A3 Design Created Date: Wednesday, December 03, 2008		Page Title	
		<b>Board Controller Power &amp; Misc</b>	
Approved: RGU BOM Doc No: <Cage Code>		Document number	
		<b>BRD4002A</b>	
Sheet Created Date: Wednesday, December 03, 2008		Revision <b>A03</b>	
Sheet Modified Date: Monday, March 23, 2020		Sheet 14 of 16	

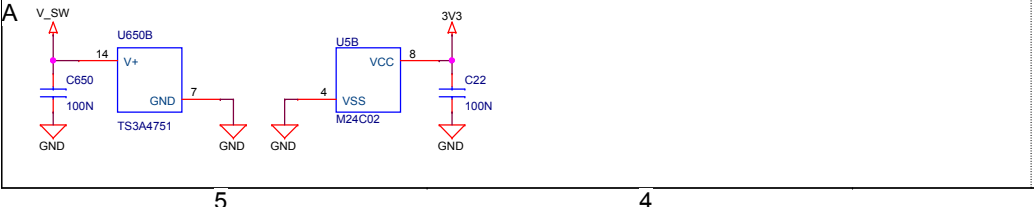
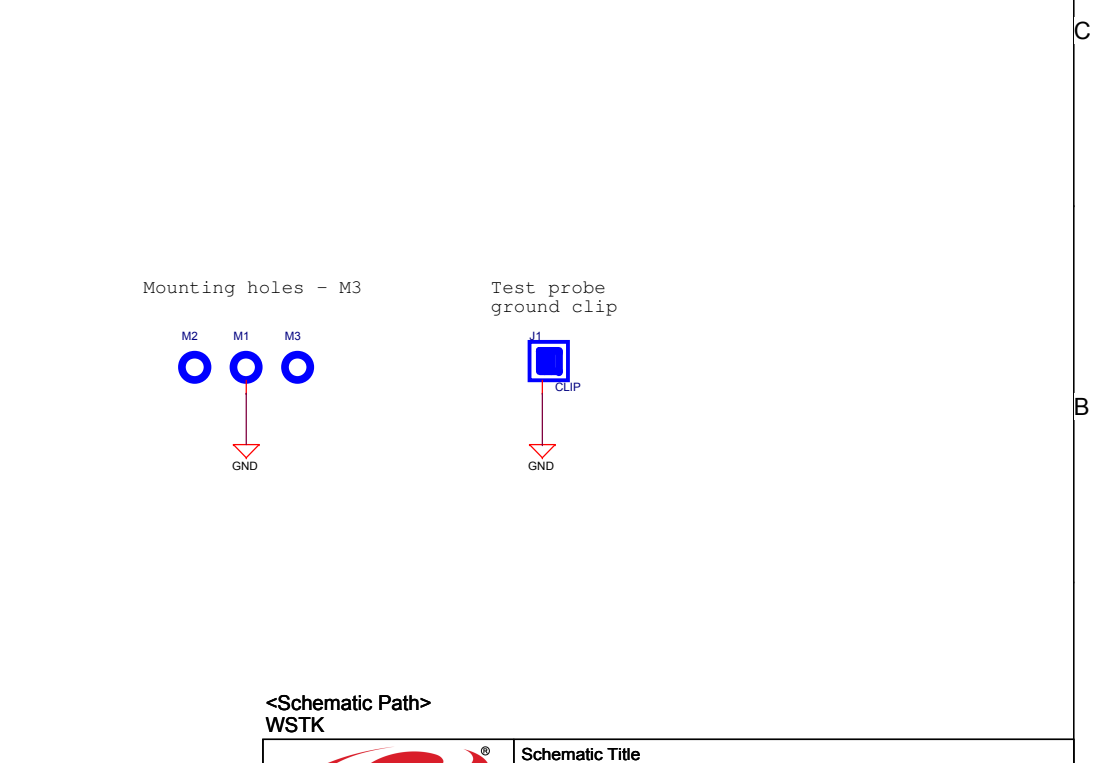
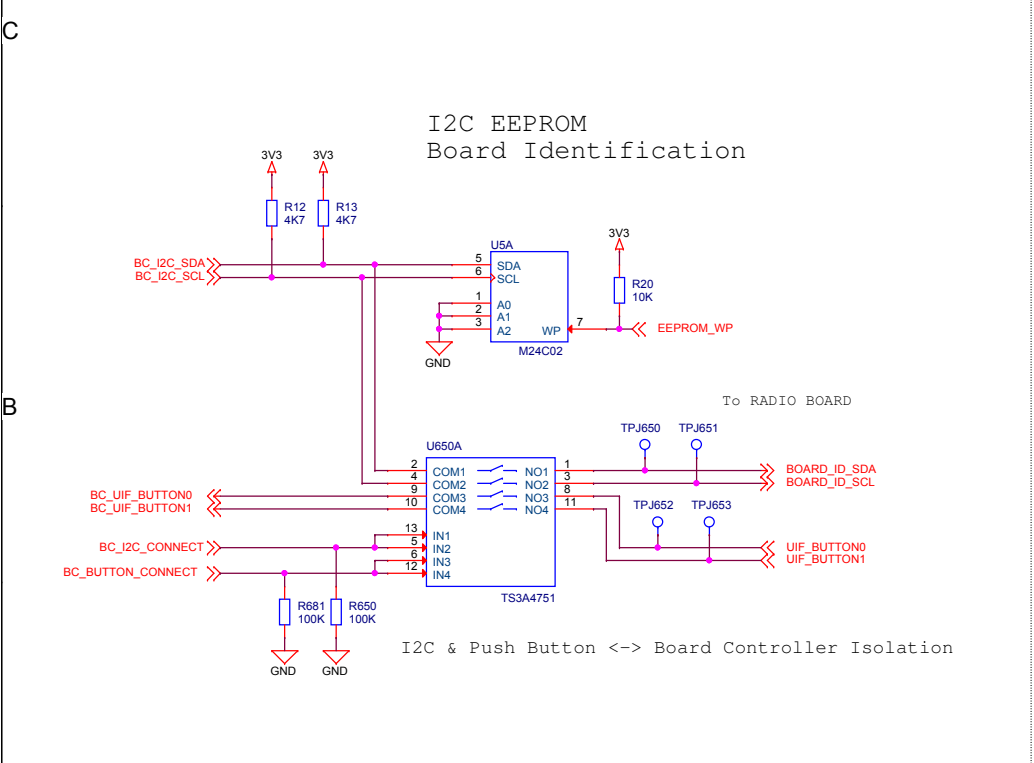
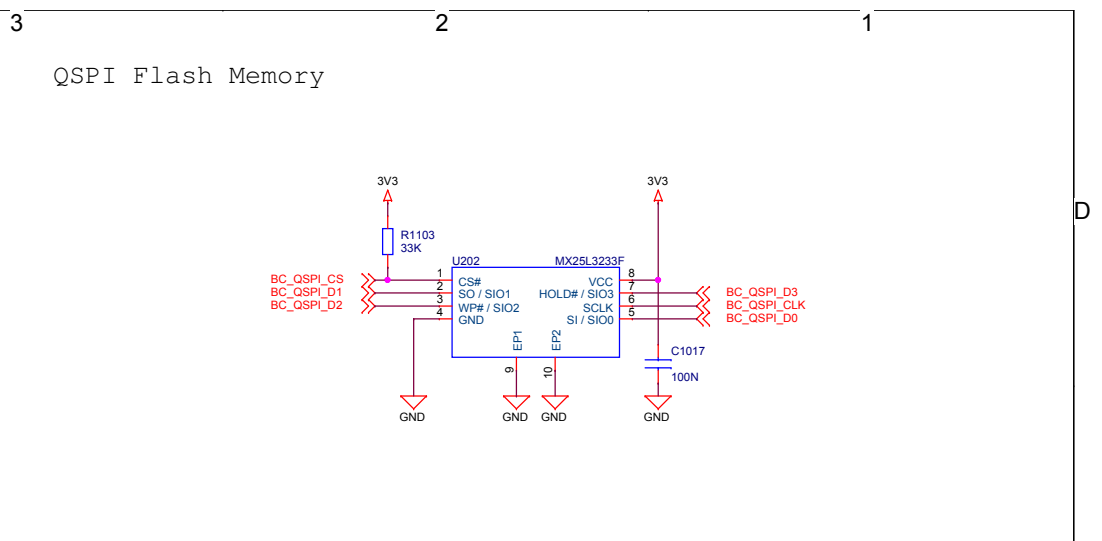
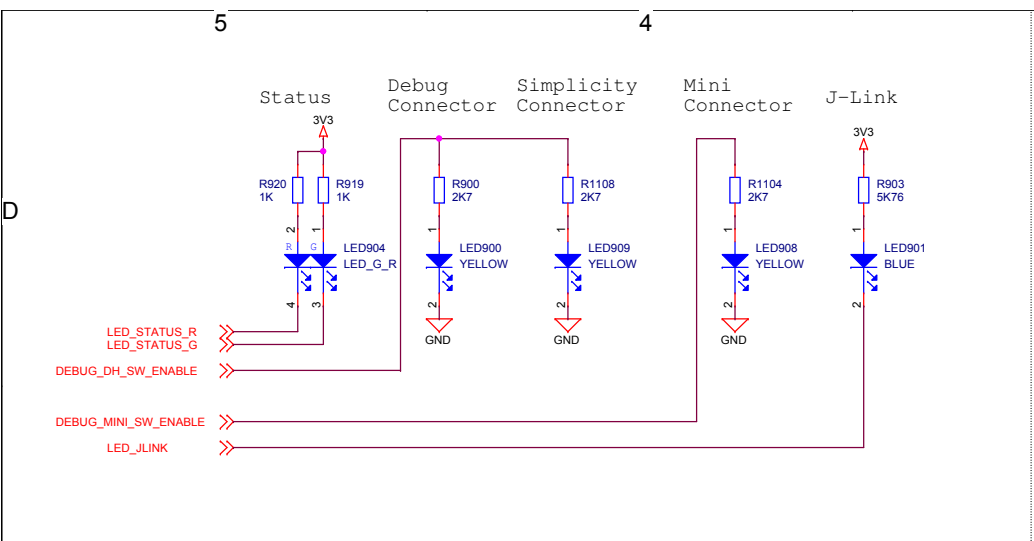

<Schematic Path>  
WSTK

		Schematic Title	
		<b>WSTK Board Controller</b>	
Designed: HEL Size: A3 Design Created Date: Wednesday, December 03, 2008		Page Title	
		<b>Board Controller Misc</b>	
Approved: RGU BOM Doc No: <Cage Code>		Document number	
		<b>BRD4002A</b>	
Revision		A03	
Sheet Created Date		Monday, March 23, 2020	
Sheet Modified Date		Wednesday, June 02, 2021	
Sheet		15 of 16	

# 10/100 Mbit Ethernet PHY

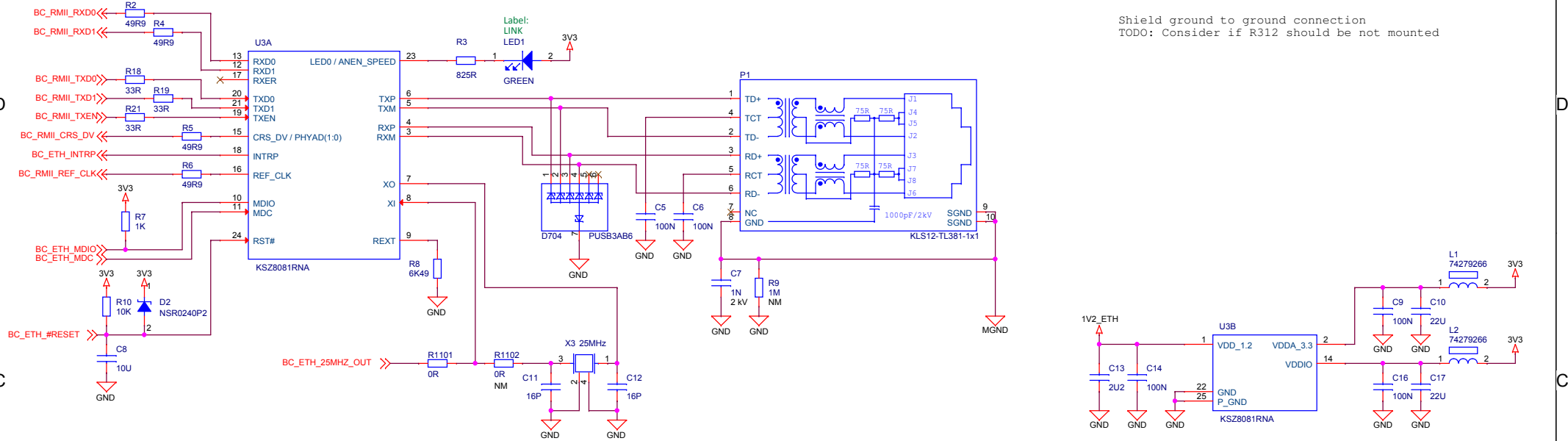

# USB High Speed

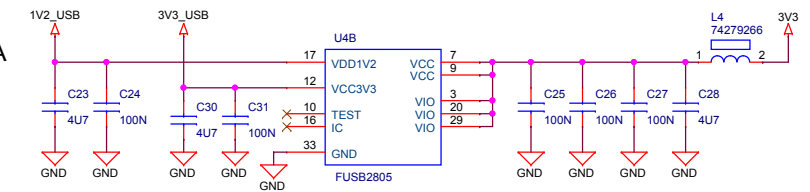
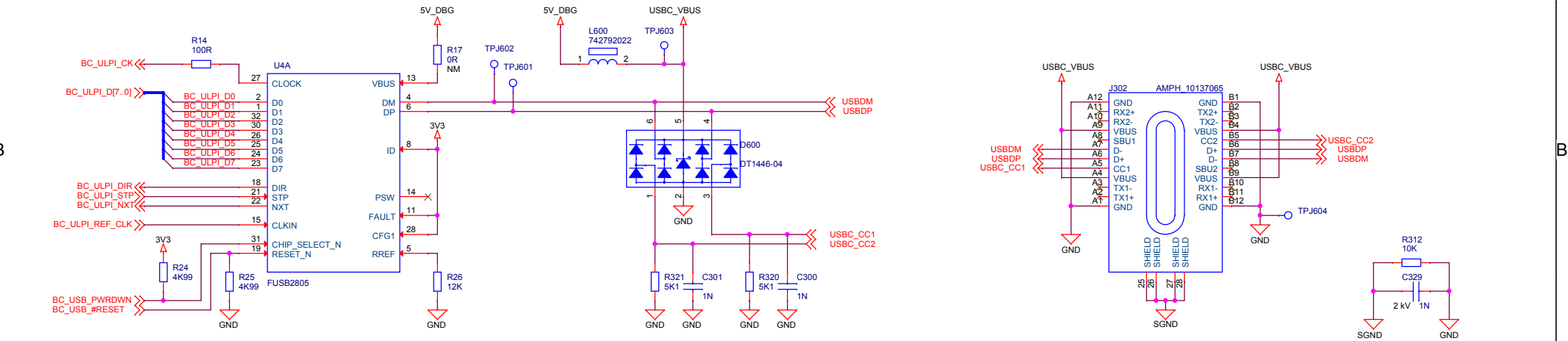

<Schematic Path>  
WSTK

		Schematic Title	
		<b>WSTK Board Controller</b>	
Designed: HEL Approved: RGU		Page Title	
		<b>Board Controller USB &amp; Ethernet</b>	
Size: A3	BOM Doc No: <Cage Code>	Document number	Revision
Design Created Date: Wednesday, December 03, 2008		<b>BRD4002A</b>	A03
Sheet Created Date: Monday, March 23, 2020	Sheet Modified Date: Wednesday, June 02, 2021		Sheet 16 of 16