



Wireless Pro Kit Mainboard	
Board Function	Page
Title Page	1
Radio Board Interface	2
User Interface	3
EXP Header & Breakout Signals	4
Advanced Energy Monitor	5,6
Voltage Regulators	7
Debug Interface	8
Simplicity Interface	9
Logic Analyzer Front End	10
Board Controller I/O	11
Board Controller Power & Misc.	12
Board Controller USB & Ethernet	13

Revision History	
Rev.	Description
A05	Initial release.
A06	Changes to SW102, R746 & R784.
A07	Replaced DMN5L06VK-7 with NX3008NBKV.



LEGAL NOTICE:
SILICON LABORATORIES INC. ("SILICON LABS") AND/OR ITS LICENSORS DO NOT WARRANT THE ACCURACY OR COMPLETENESS OF THIS SCHEMATIC OR ANY INFORMATION CONTAINED WITHIN THIS SCHEMATIC. IT IS PROVIDED "AS-IS" FOR REFERENCE ONLY. SILICON LABS DOES NOT WARRANT THAT THIS DESIGN WILL MEET THE SPECIFICATIONS, BE SUITABLE FOR YOUR APPLICATION OR FIT FOR ANY PARTICULAR PURPOSE, OR WILL OPERATE IN YOUR IMPLEMENTATION. SILICON LABS AND ITS LICENSORS DO NOT WARRANT THAT THE DESIGN IMPLIED IN THIS SCHEMATIC IS PRODUCTION-WORTHY. YOU SHOULD COMPLETELY VALIDATE AND TEST YOUR DESIGN IMPLEMENTATION TO CONFIRM SYSTEM FUNCTIONALITY FOR YOUR APPLICATION.

 SILICON LABS		Board Name	
		Wireless Pro Kit Mainboard	
Designed HEL		Page Title	
		Title Page	
Size A3		Board Number	
		BRD4002A	
Sheet Modified Date Wednesday, May 31, 2023		Revision	
		A07	
COPYRIGHT SILICON LABORATORIES INC. 2023 CONFIDENTIAL – SUBJECT TO TERMS OF USE			Sheet 1 of 14

Radio Board Socket

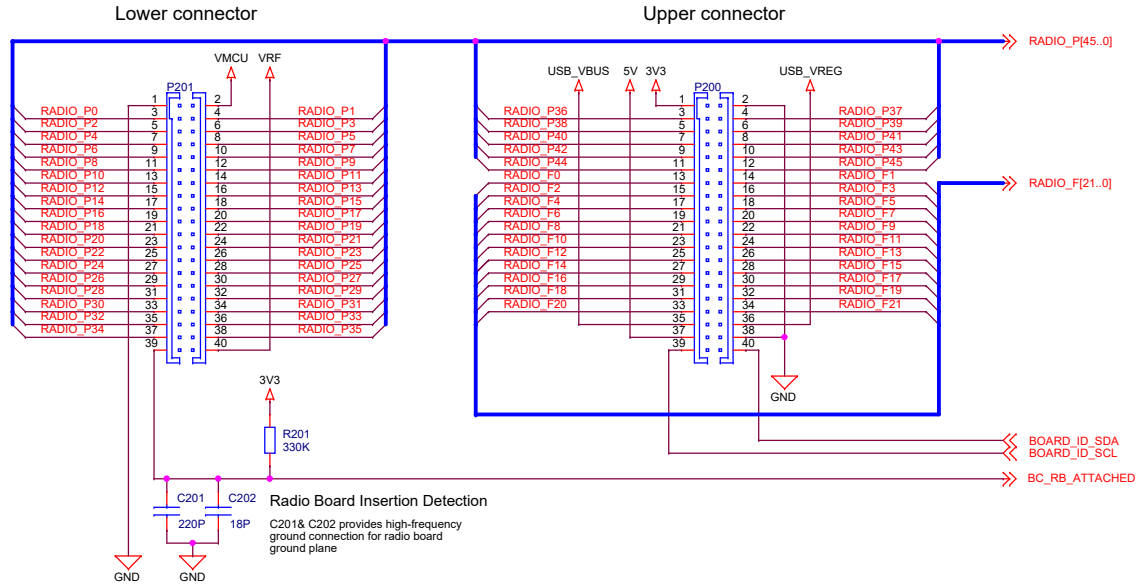

Radio Board Signal Assignments

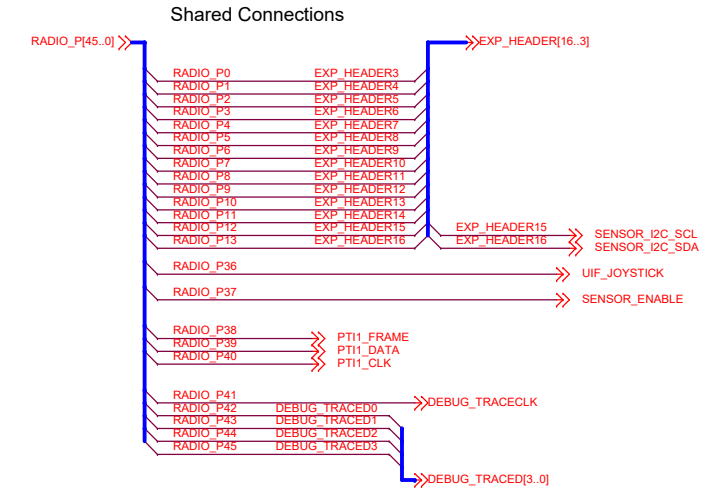
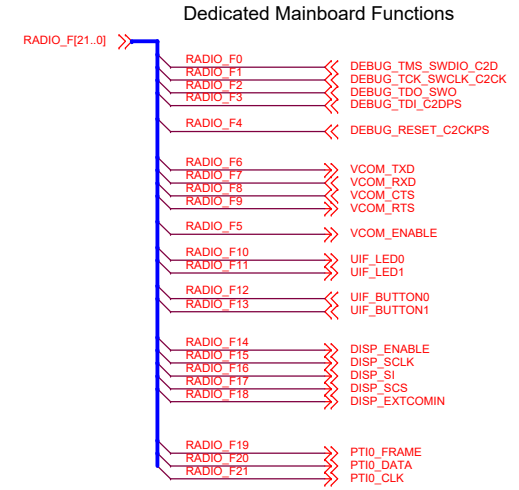

Radio Board Power Selection Switch

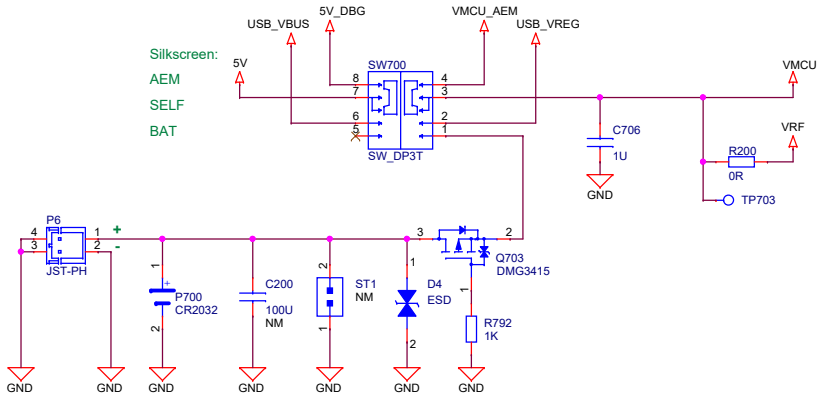

Switch Pos.	VMCU Source	5V Source
AEM	AEM output	5V_DBG from debug USB
SELF	USB_VREG pin on radio board	USB_VBUS pin on radio board
BAT	Coin cell battery, P6 or ST1	Not connected

VCOM Enable Indicator LED

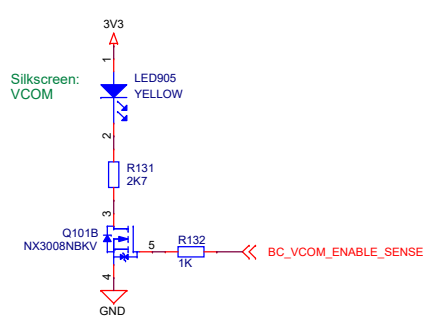

 SILICON LABS		Board Name	
		Wireless Pro Kit Mainboard	
Designed HEL		Page Title	
		Radio Board Interface	
Size A3		Board Number	Revision
Sheet Modified Date Wednesday, May 31, 2023		BRD4002A	A07
COPYRIGHT SILICON LABORATORIES INC. 2023 CONFIDENTIAL - SUBJECT TO TERMS OF USE			
Sheet 2 of 14			

Memory LCD-TFT Display & Multiplexer

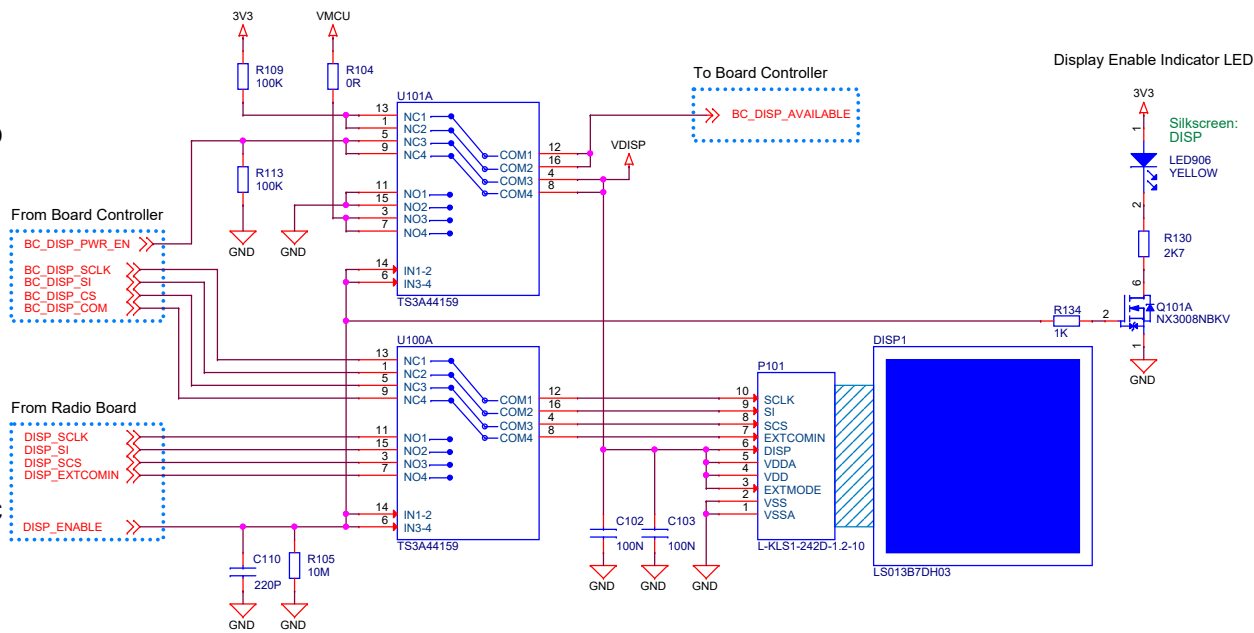

DISP_ENABLE	Display Controller	VDISP source	BC_DISP_AVAILABLE
1	Radio Board Control MCU	VMCU BC_DISP_PWR_EN	0
0	Radio Board Control MCU	VMCU BC_DISP_PWR_EN	1

The radio board always controls ownership of the display using the DISP_ENABLE signal

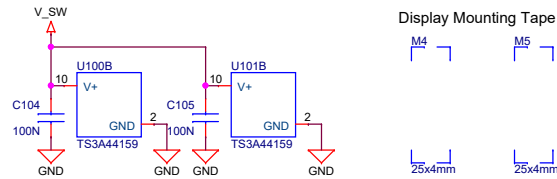

Relative Humidity & Temperature Sensor

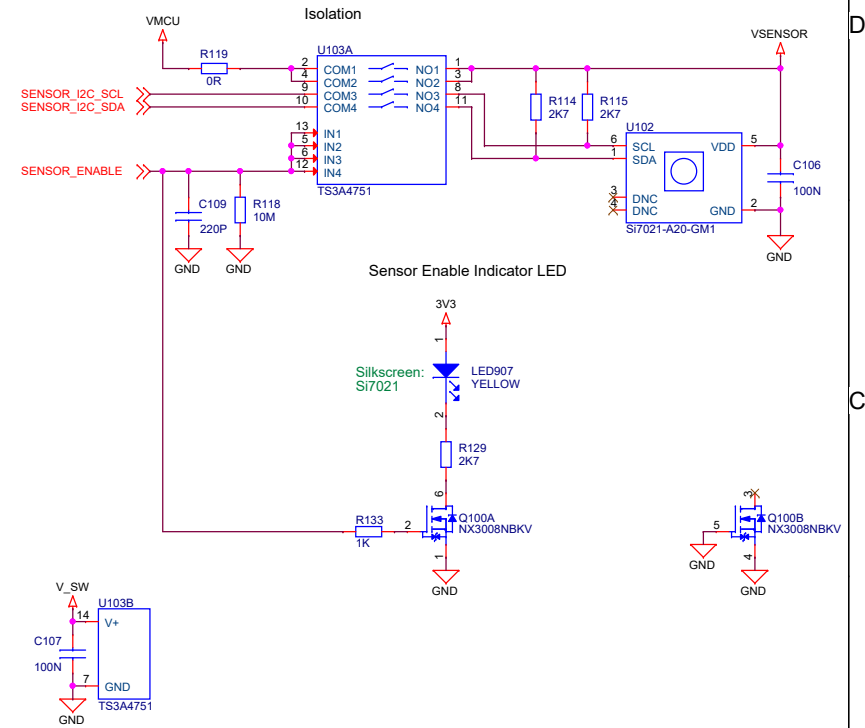

User Buttons & Joystick

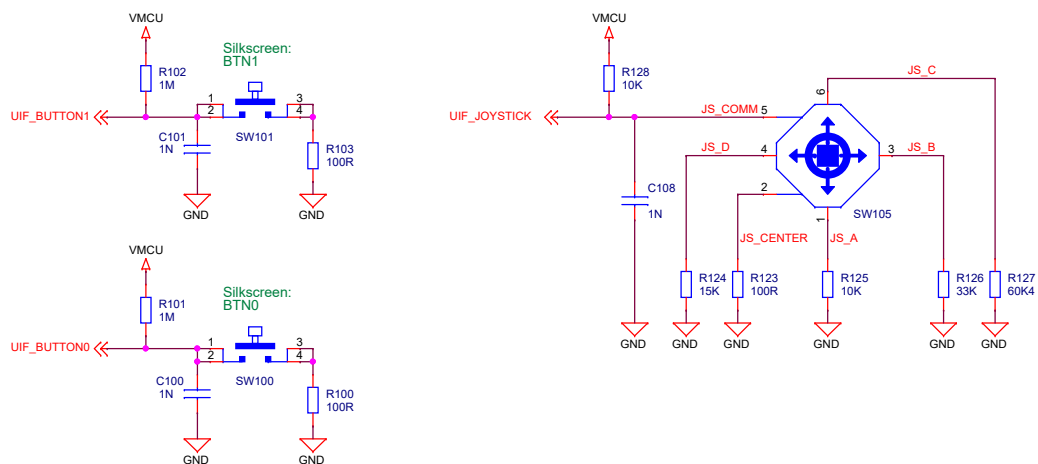

User LEDs

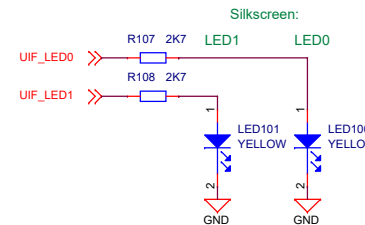

Reset Pushbutton

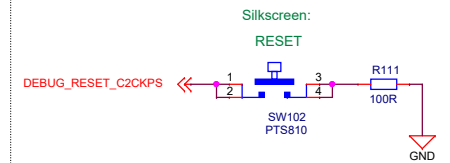

 SILICON LABS		Board Name	
		Wireless Pro Kit Mainboard	
Designed HEL		Page Title	
		User Interface	
Size A3		Board Number	
		BRD4002A	
Sheet Modified Date Wednesday, May 31, 2023		Revision	
		A07	
COPYRIGHT SILICON LABORATORIES INC. 2023 CONFIDENTIAL – SUBJECT TO TERMS OF USE			
		Sheet 3 of 14	

Radio Board Breakout Connections

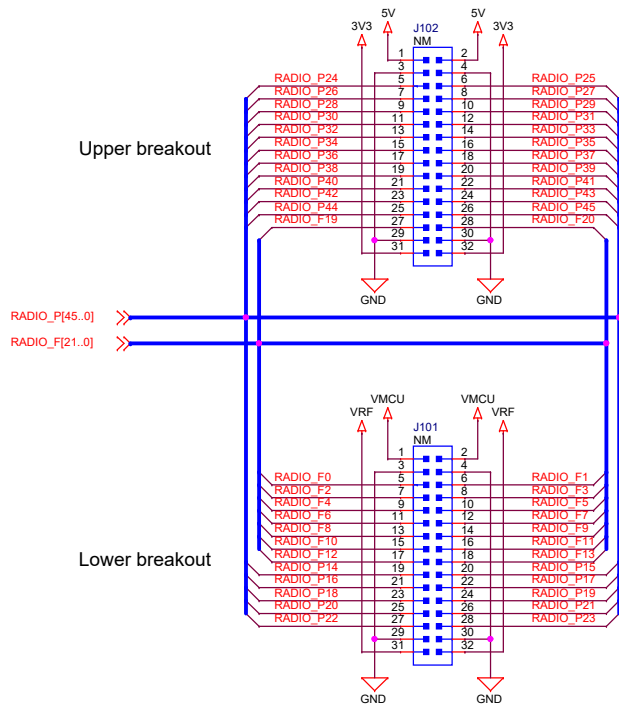

EXP Header

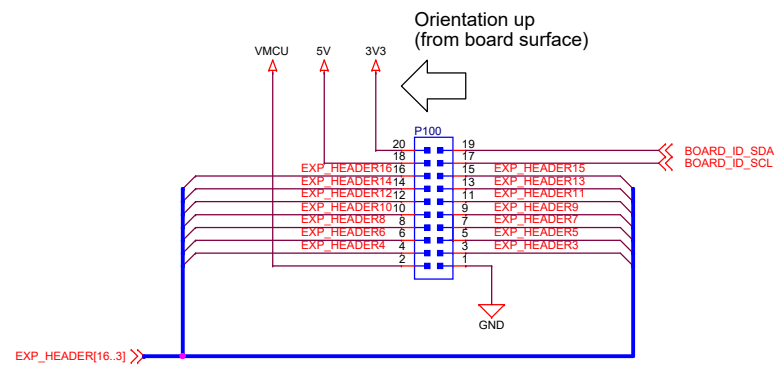



EXP header functionality

1	GND
3	
5	
7	
9	
11	
13	
15	I2C_SCL
17	Reserved for EXP Board ID
19	Reserved for EXP Board ID
2	VMCU
4	SPI_MOSI
6	SPI_MISO
8	SPI_SCLK
10	SPI_CS
12	UART_TX
14	UART_RX
16	I2C_SDA
18	5V
20	3V3

 SILICON LABS		Board Name	
		Wireless Pro Kit Mainboard	
Designed HEL		Page Title	
		EXP Header & Breakout Signals	
Size A3		Board Number	Revision
Sheet Modified Date Wednesday, May 31, 2023		BRD4002A	A07
COPYRIGHT SILICON LABORATORIES INC. 2023 CONFIDENTIAL – SUBJECT TO TERMS OF USE			Sheet 4 of 14

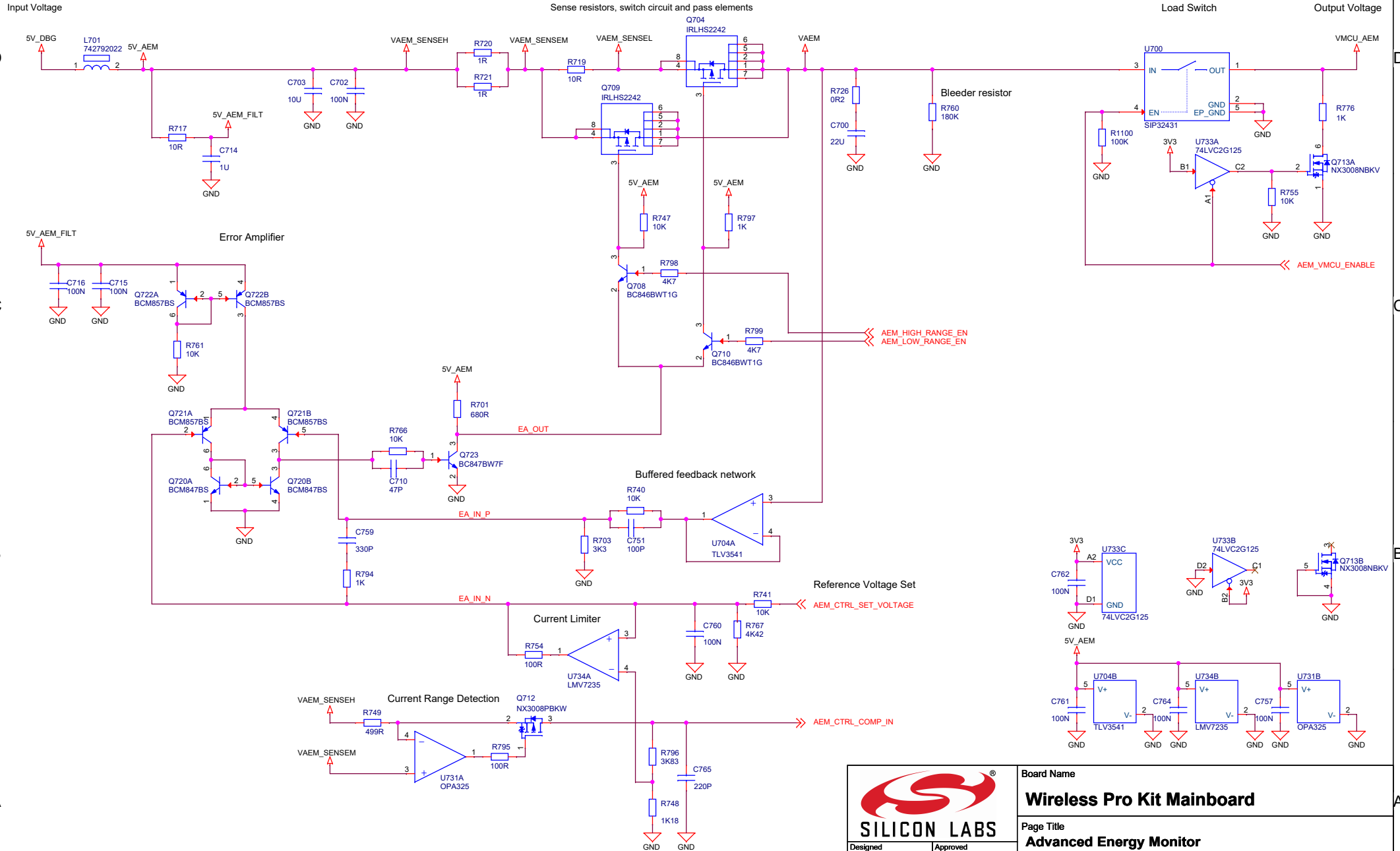
Advanced Energy Monitor



 SILICON LABS		Board Name	
		Wireless Pro Kit Mainboard	
Designed HEL		Page Title	
		Advanced Energy Monitor	
Size A3		Board Number BRD4002A	
Sheet Modified Date Wednesday, May 31, 2023		Revision A07	
COPYRIGHT SILICON LABORATORIES INC. 2023 CONFIDENTIAL – SUBJECT TO TERMS OF USE			
Sheet 5 of 14			

AEM Current Sense

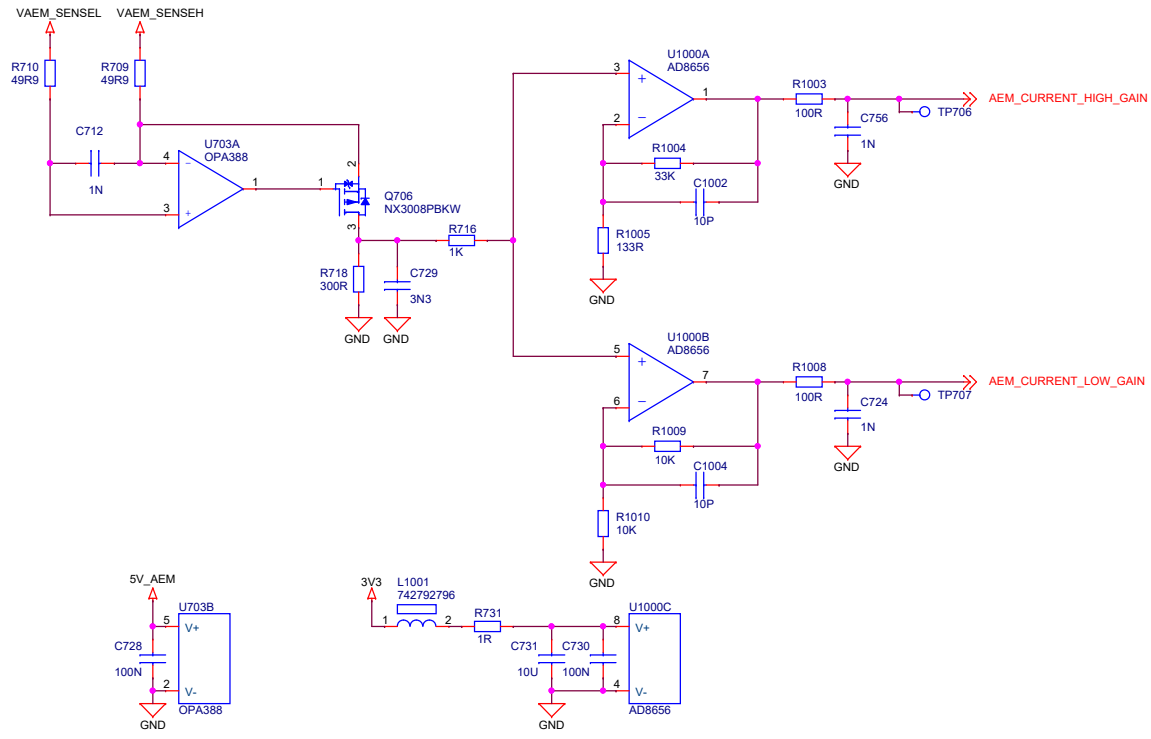

AEM Range Control

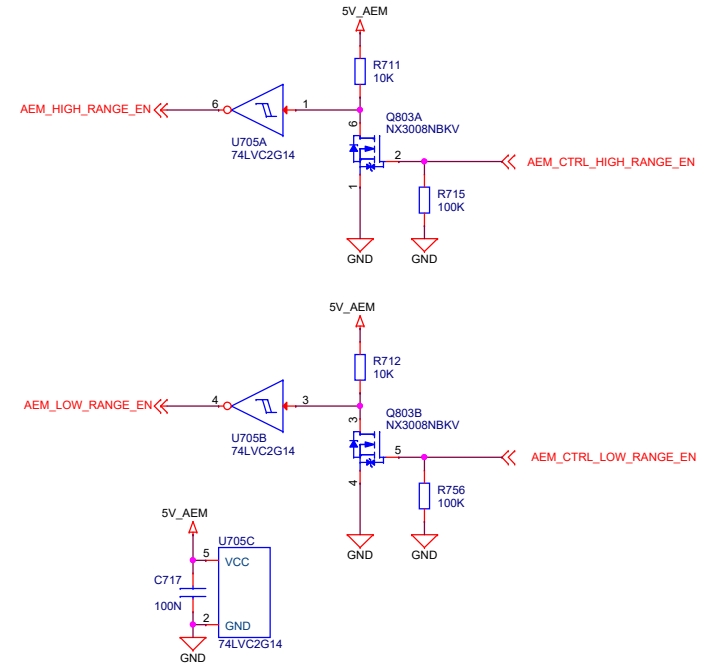

AEM Test Circuit

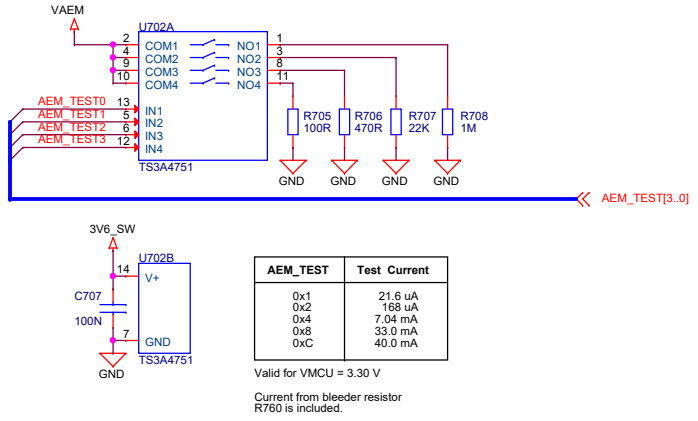

AEM Voltage Sense

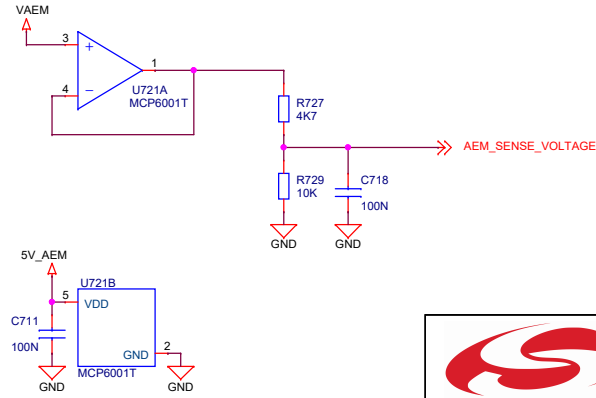

AEM Temperature Sensor

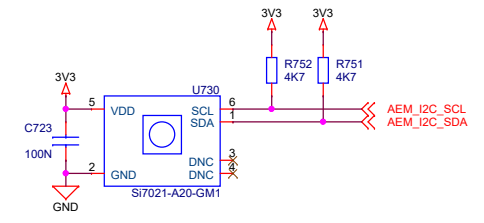

 SILICON LABS		Board Name	
		Wireless Pro Kit Mainboard	
Designed HEL		Approved RGU	
Page Title		Revision	
AEM Range Selection		A07	
Board Number		Revision	
BRD4002A		A07	
Size A3		Sheet Modified Date Wednesday, May 31, 2023	
COPYRIGHT SILICON LABORATORIES INC. 2023		CONFIDENTIAL – SUBJECT TO TERMS OF USE	
Sheet 6 of 14			

3V3 Regulator

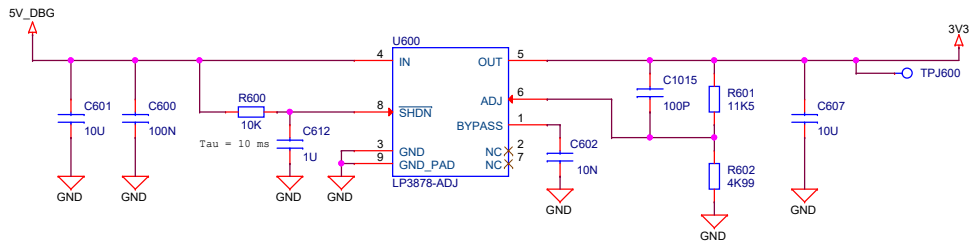

5V Misc.

Supply for Isolation Switches

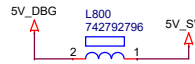

Control Signal for Isolation Switches

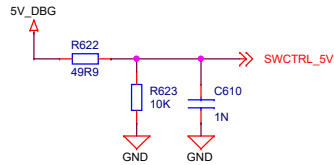

VMCU Voltage Mirror

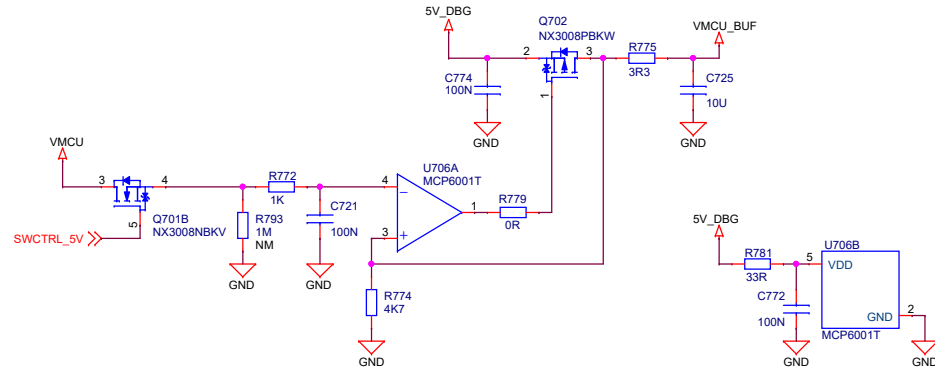

VTarget Voltage Mirror

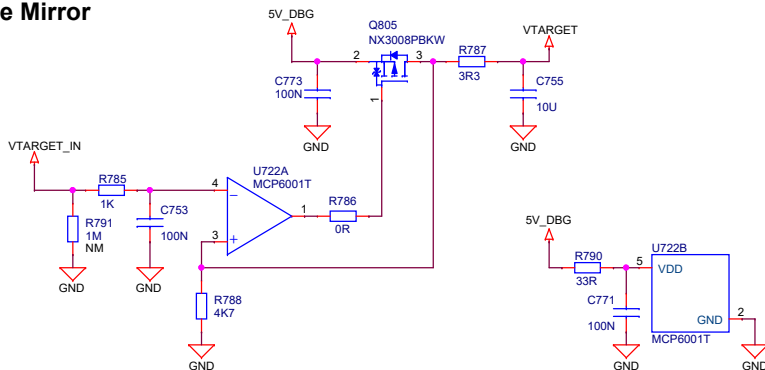

Power Supply for Isolation Switches

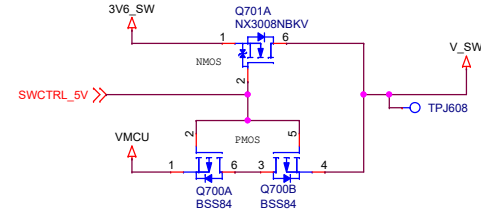
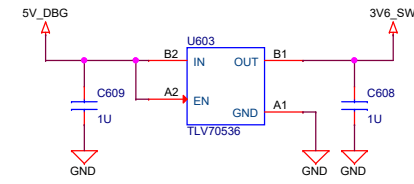

J-Link USB Cable	Q700 State	Q701A State	V_SW	VMCU_SENSE
Connected	OFF	ON	3.6V	VMCU
Disconnected	ON	OFF	VMCU	Isolated

Isolation switches are powered by 3V6_SW when the USB cable is connected, otherwise by VMCU.

Voltage Sensing

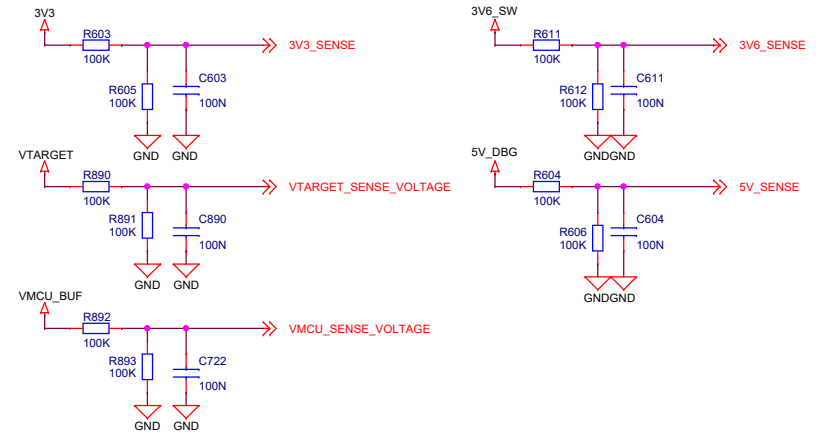

 SILICON LABS		Board Name	
		Wireless Pro Kit Mainboard	
Designed HEL		Page Title	
		Voltage Regulators	
Size A3		Board Number	Revision
Sheet Modified Date Wednesday, May 31, 2023		BRD4002A	A07
COPYRIGHT SILICON LABORATORIES INC. 2023 CONFIDENTIAL - SUBJECT TO TERMS OF USE			Sheet 7 of 14

Debug Interface

Debug Connector

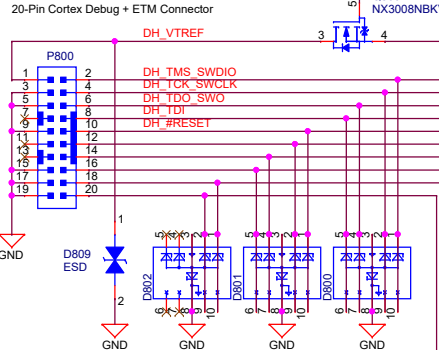

To Radio Board Socket (p.2)

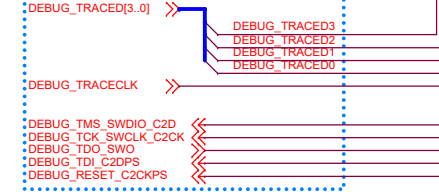

Mini Simplicity Connector

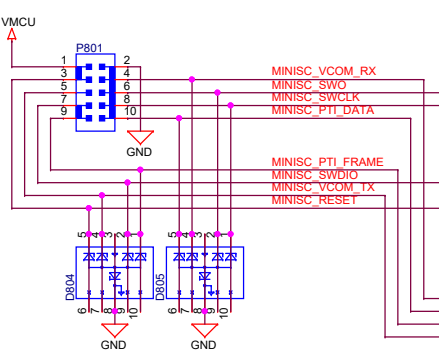

Mini Simplicity PTI & VCOM (p.9)



Isolation Switch Power

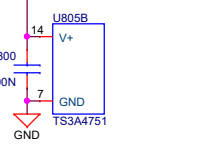

Debug Mux Switch Power

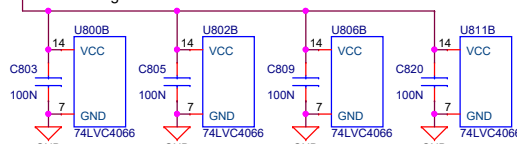

Debug Mux

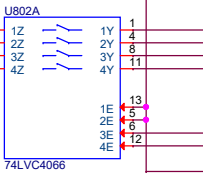
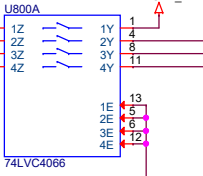

Debug Mux

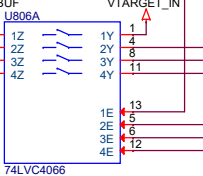

Debug Mux

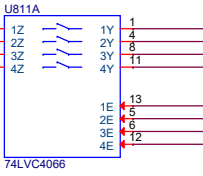

Debug Signals



Debug Mux Control Signals (p. 10)

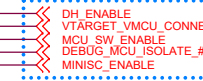

Debug Mode	DH_ENABLE	MCU_SW_ENABLE	MINI_SW_ENABLE
MCU	0	1	0
Debug Out	1	0	0
Mini Out	0	0	1
Debug In	1	1	0
Debug Off	0	0	0

Debug Mode	VTARGET Source	VTREF Source
MCU	VMCU	None
Debug Out	VTREF (EXT)	External
Mini Out	VMCU	None
Debug In	VMCU	VMCU_BUF
Debug Off	VMCU	None

Indicator LEDs

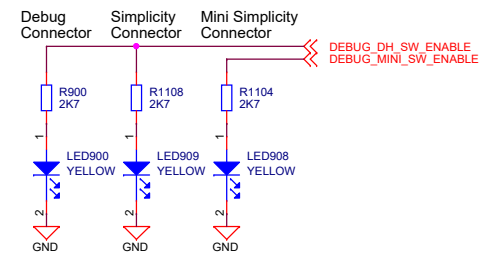



SILICON LABS

Designed HEL Approved RGU

Size A3 Sheet Modified Date Wednesday, May 31, 2023

COPYRIGHT SILICON LABORATORIES INC. 2023 CONFIDENTIAL – SUBJECT TO TERMS OF USE

Board Name
Wireless Pro Kit Mainboard

Page Title
Debug Interface

Board Number
BRD4002A

Revision
A07

Sheet 8 of 14

Simplicity Interface

Simplicity Connector

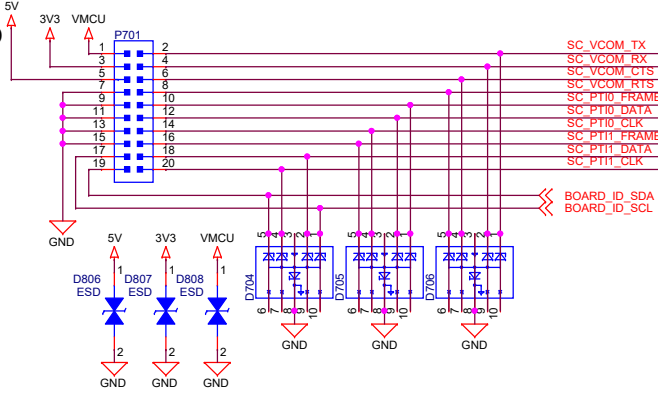

Mini Simplicity Connector (p.8)

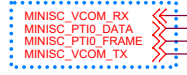

To Radio Board Socket (p.2)

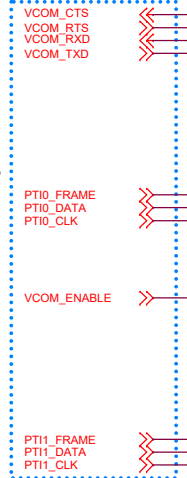

Isolation Switch Power

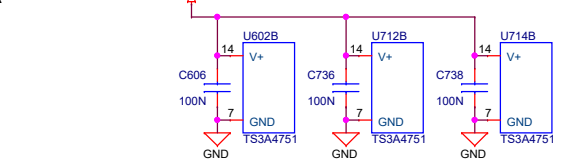

Debug Mux Power

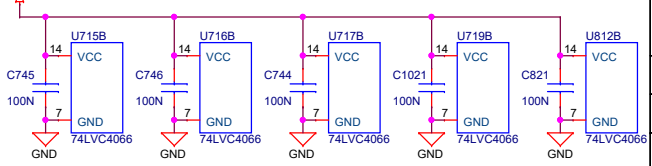

Debug Mux

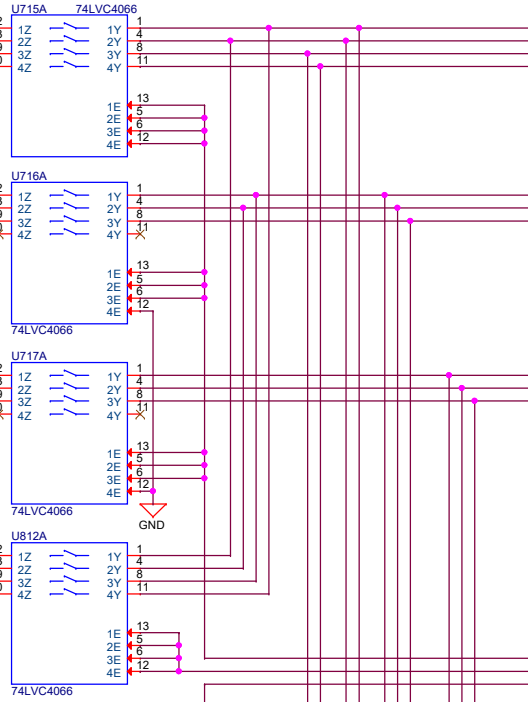

VCOM & PTI Signals (p. 10)

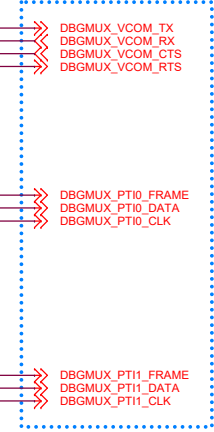

Debug Mux Control Signals (p.10)

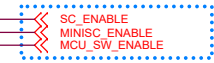

Debug Mode	SC_ENABLE	MCU_SW_ENABLE	MINI_SW_ENABLE
MCU	0	1	0
Debug Out	1	0	0
Mini Out	0	0	1
Debug In	1	1	0
Debug Off	0	0	0



SILICON LABS

Board Name
Wireless Pro Kit Mainboard

Page Title
Simplicity Interface

Board Number
BRD4002A

Revision
A07

Designed
HEL

Approved
RGU

Size
A3

Sheet Modified Date
Wednesday, May 31, 2023

COPYRIGHT SILICON LABORATORIES INC. 2023 CONFIDENTIAL – SUBJECT TO TERMS OF USE

Sheet
9 of 14

Debug Interface Level Shifting

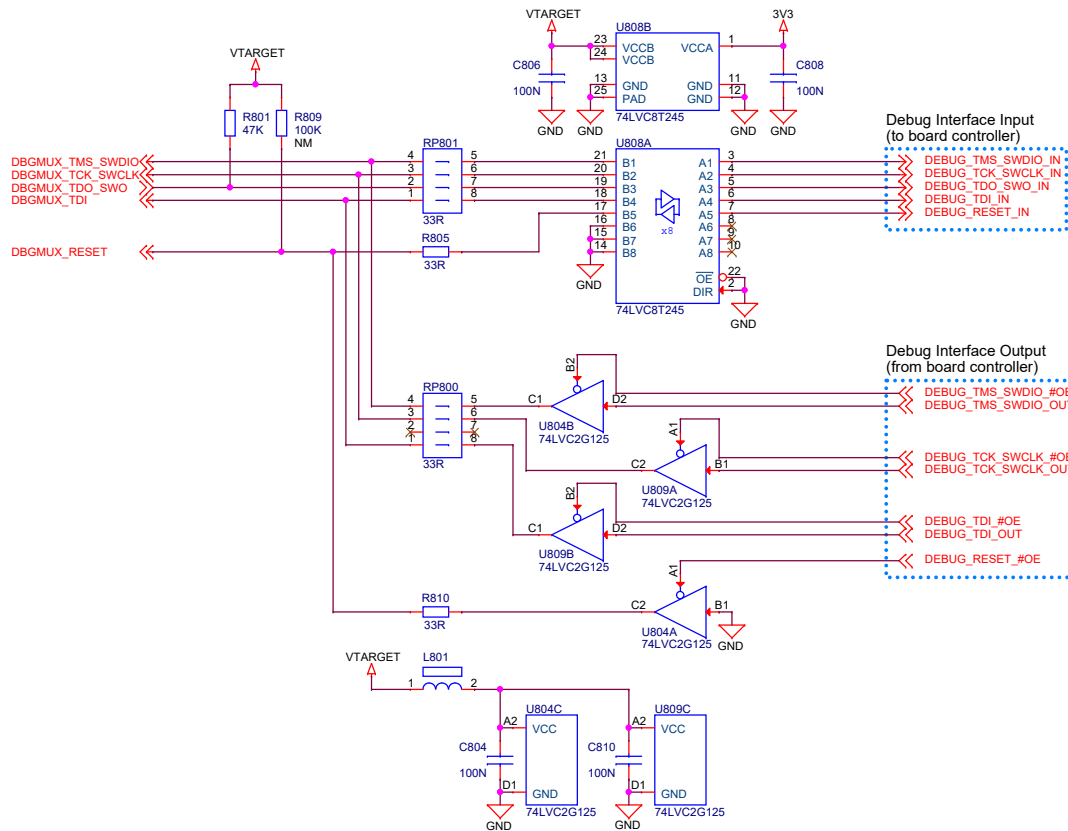

Simplicity Interface Level Shifting

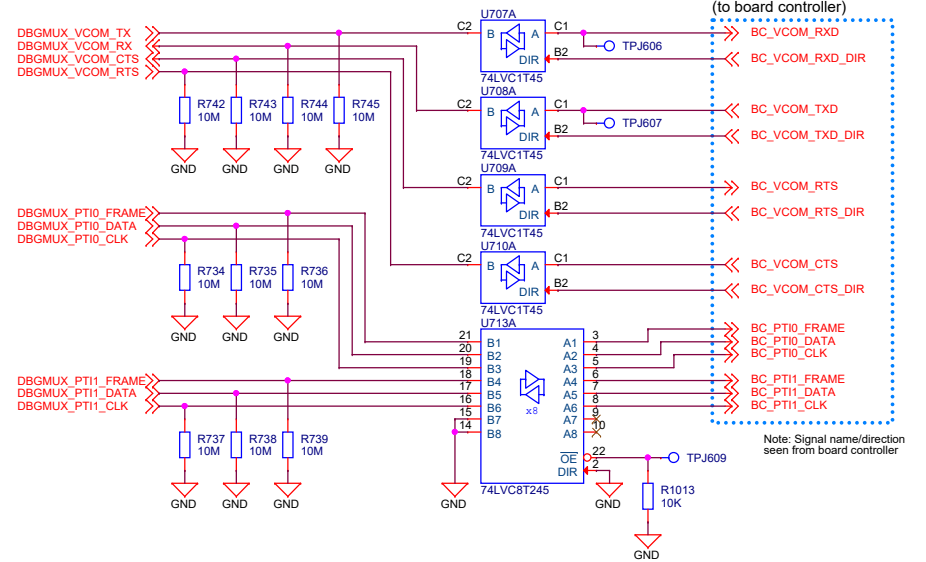

Level Shifter Power

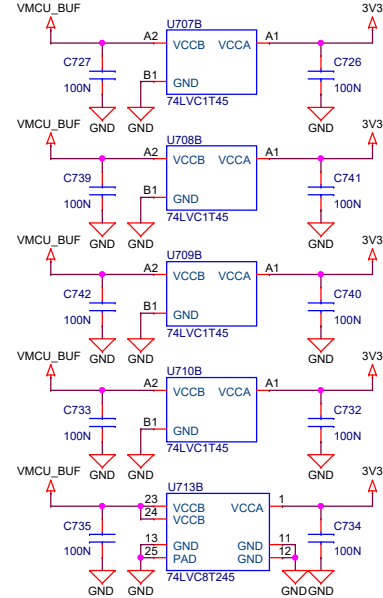

Debug Mode	BC_VCOM_TX_DIR	BC_VCOM_RX_DIR
MCU	1	0
Debug Out	1	0
Mini Out	1	0
Debug In	0	0
Debug Off	0	0

Debug Mode	BC_VCOM_RTS_DIR	BC_VCOM_CTS_DIR
MCU	1	0
Debug Out	1	0
Mini Out	0	0
Debug In	0	0
Debug Off	0	0

Debug Mux Control Signal Level Shifting

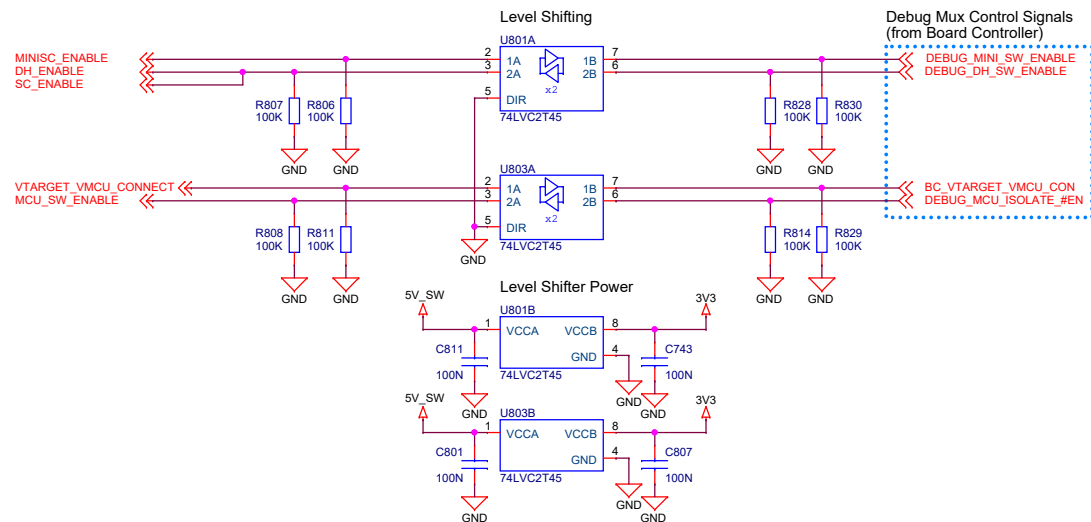



SILICON LABS

Board Name
Wireless Pro Kit Mainboard

Page Title
Debug Mux Level Shifting

Board Number
BRD4002A

Revision
A07

Designed HEL	Approved RGU
Size A3	Sheet Modified Date Wednesday, May 31, 2023

COPYRIGHT SILICON LABORATORIES INC. 2023 CONFIDENTIAL – SUBJECT TO TERMS OF USE

Sheet 10 of 14

Logic Analyzer Front End

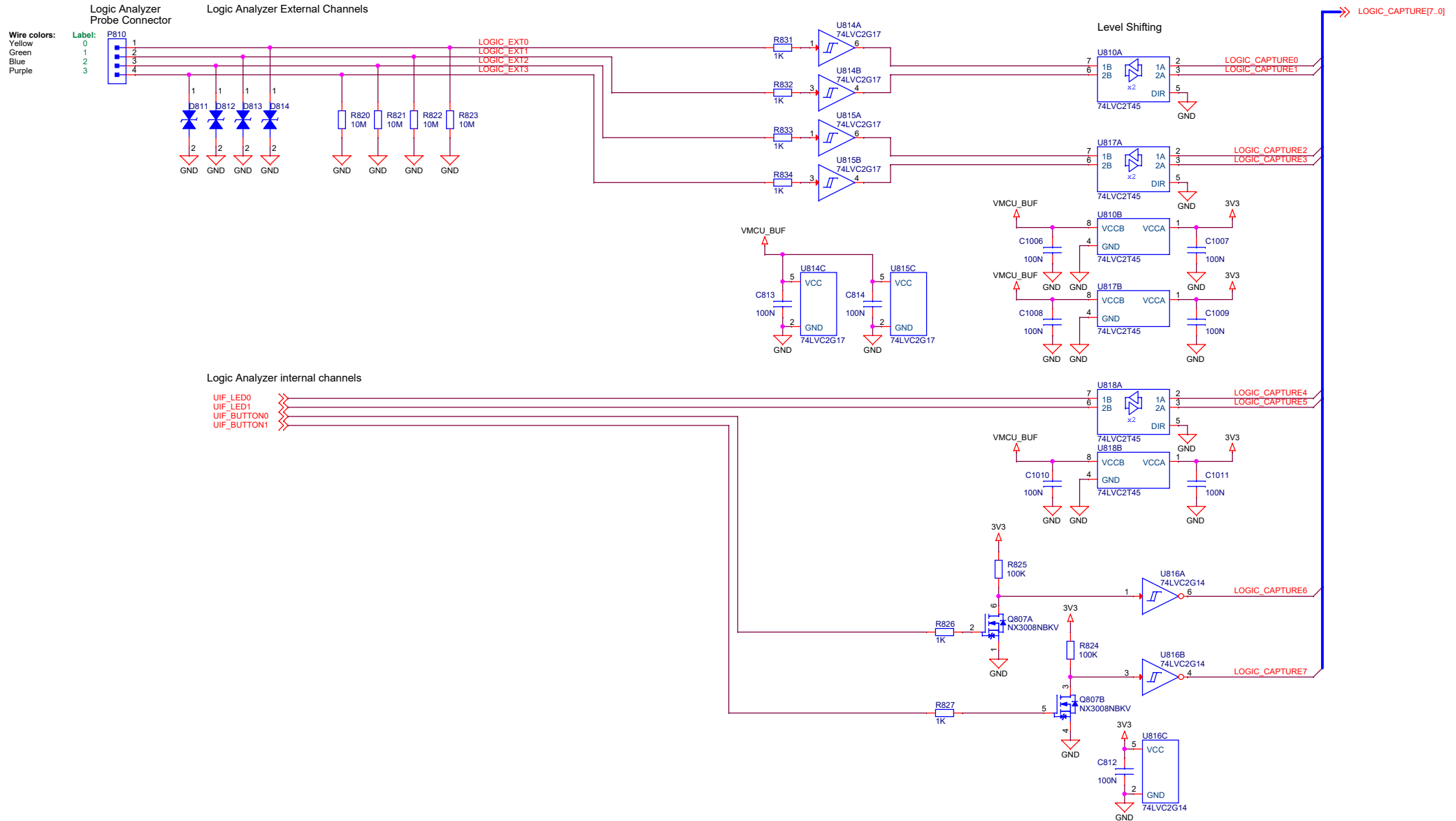

 SILICON LABS		Board Name	
		Wireless Pro Kit Mainboard	
Designed		Page Title	
HEL		Logic Analyzer Front End	
Approved		Board Number	
RGU		BRD4002A	
Size	Sheet Modified Date	Revision	
A3	Wednesday, May 31, 2023	A07	
COPYRIGHT SILICON LABORATORIES INC. 2023 CONFIDENTIAL – SUBJECT TO TERMS OF USE			
Sheet 11 of 14			

Board Controller Crystal

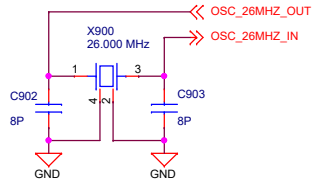

Board Controller ADC Reference

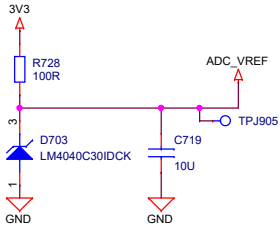

Board Controller Serial Flash Memory

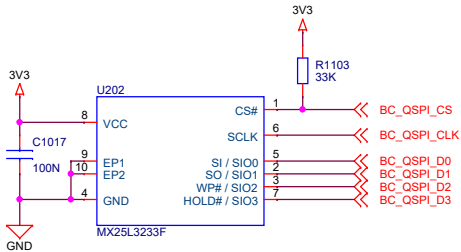

Board Controller Indicator LEDs

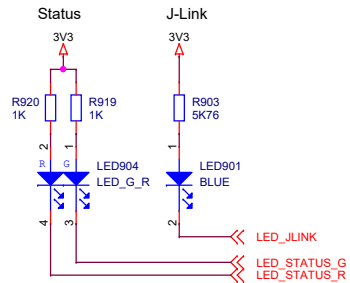

Board Controller I/O

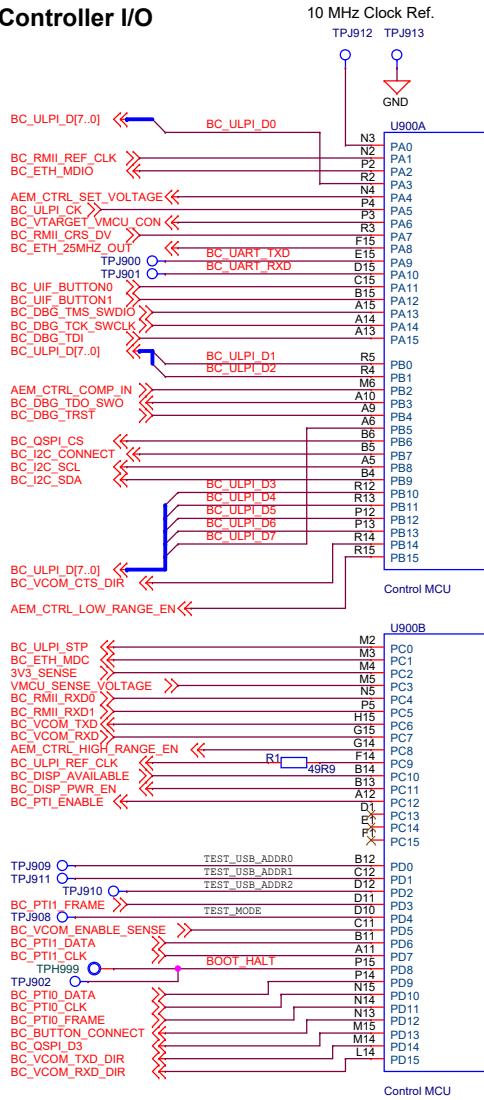

Board Controller Test Points

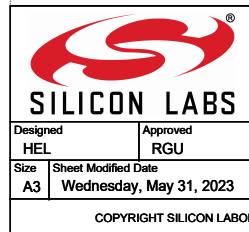
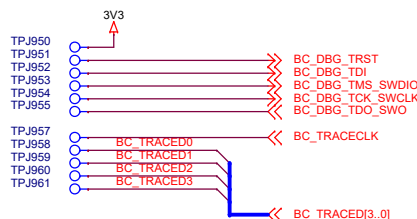

Board Name		Wireless Pro Kit Mainboard	
Page Title		Board Controller I/O	
Board Number		BRD4002A	
Revision		A07	
Sheet		12 of 14	

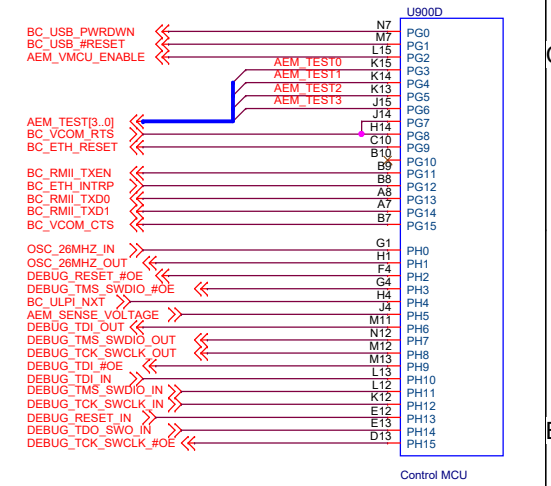
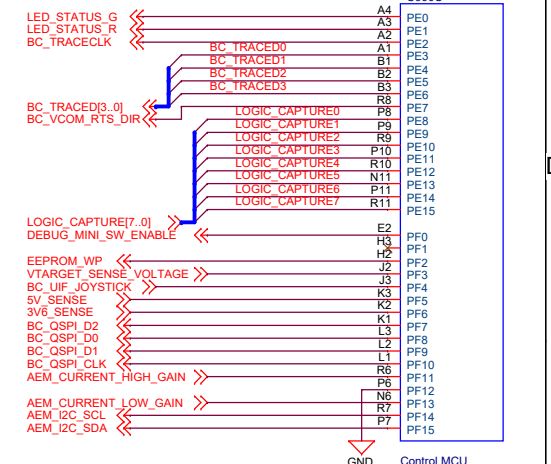

Board Controller Joystick Connection

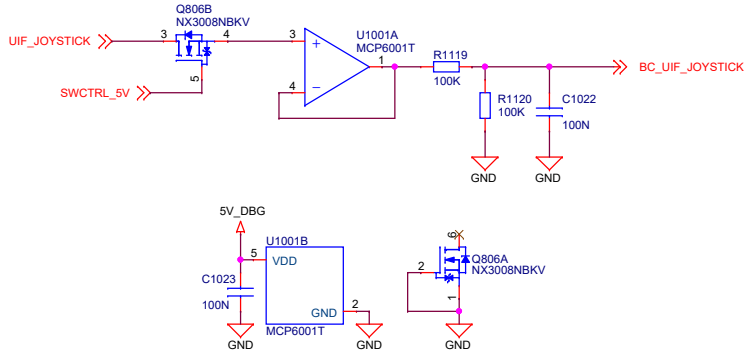

Board Controller Button Connection

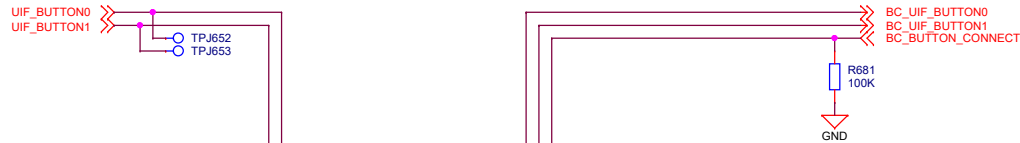

Board ID

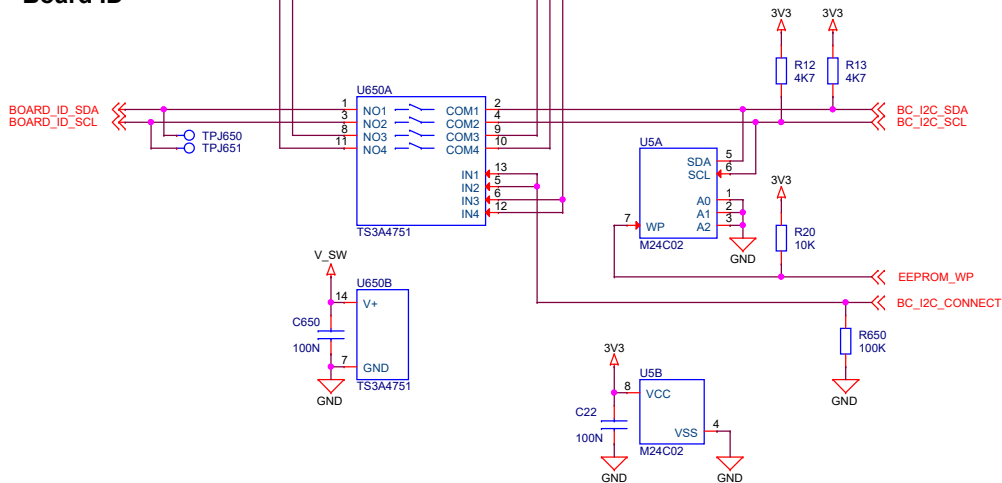

Board Controller Power & Decoupling

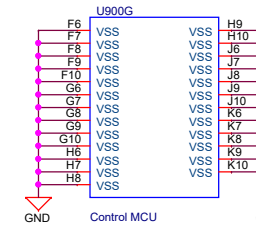
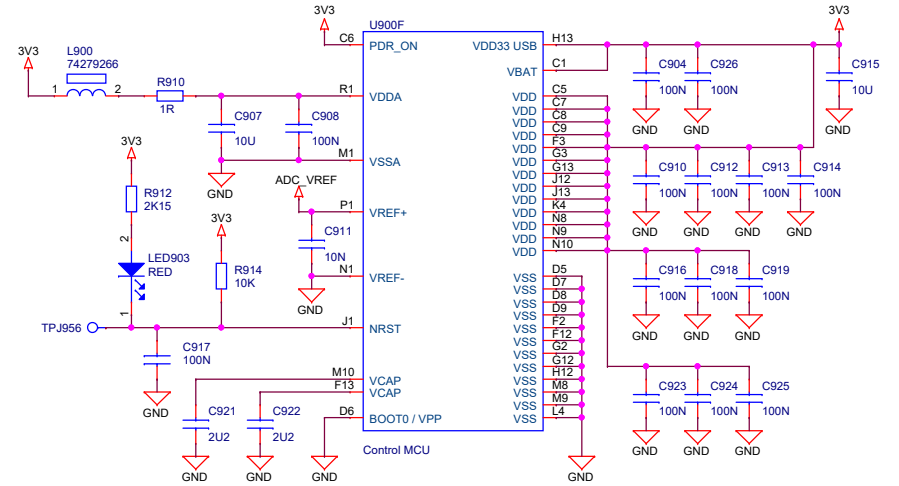

Mounting Holes

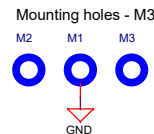

		Board Name	
		Wireless Pro Kit Mainboard	
Designed HEL		Page Title	
		Board Controller Power & Misc	
Size A3		Board Number	
		BRD4002A	
Sheet Modified Date Wednesday, May 31, 2023		Revision	
		A07	
COPYRIGHT SILICON LABORATORIES INC. 2023		CONFIDENTIAL – SUBJECT TO TERMS OF USE	
Sheet 13 of 14			

10/100 Mbit Ethernet PHY

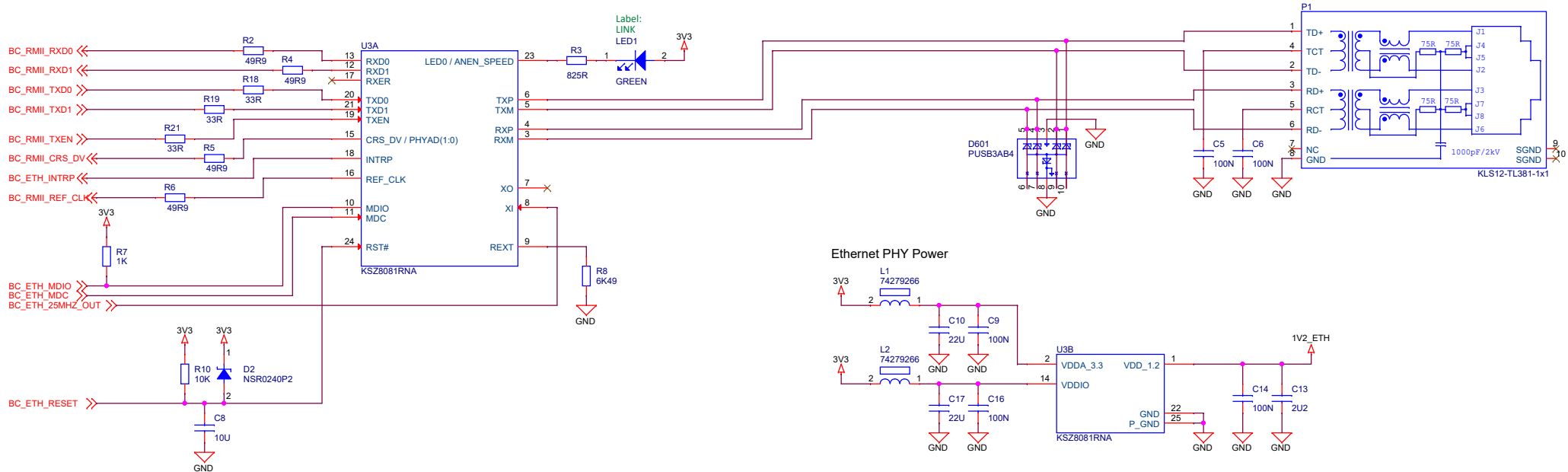

USB High Speed

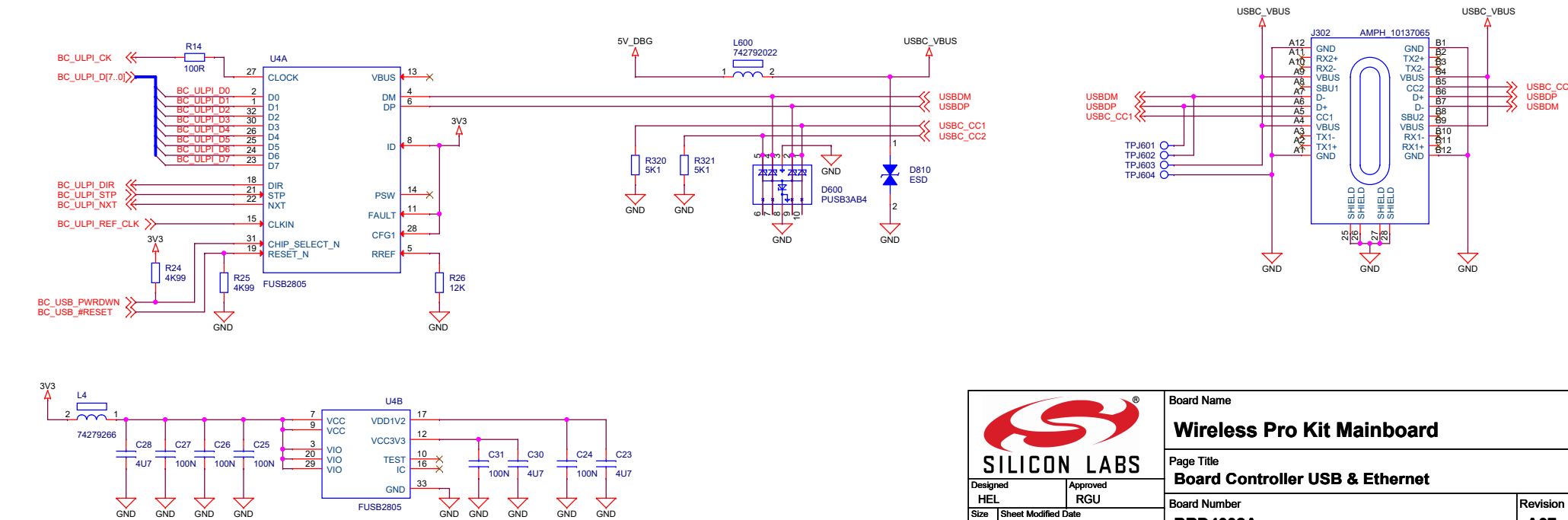

 SILICON LABS		Board Name	
		Wireless Pro Kit Mainboard	
Designed HEL		Approved	
		RGU	
Size	Sheet Modified Date	Board Number	
A3	Wednesday, May 31, 2023	BRD4002A	
COPYRIGHT SILICON LABORATORIES INC. 2023 CONFIDENTIAL – SUBJECT TO TERMS OF USE			Revision
			A07
			Sheet
			14 of 14