



EFR32 Mighty Gecko Radio Board

2.4 GHz / 868 MHz 10 dBm, VDCDC to PAVDD

Board Function	Page
Title Page	1
RF, Antenna & Power	2
EFR32 Signal Assignments	3
WSTK Connectors & Board ID	4

LEGAL NOTICE:
 SILICON LABORATORIES INC. ("SILICON LABS") AND/OR ITS LICENSORS DO NOT WARRANT THE ACCURACY OR COMPLETENESS OF THIS SCHEMATIC OR ANY INFORMATION CONTAINED WITHIN THIS SCHEMATIC. IT IS PROVIDED "AS-IS" FOR REFERENCE ONLY. SILICON LABS DOES NOT WARRANT THAT THIS DESIGN WILL MEET THE SPECIFICATIONS, BE SUITABLE FOR YOUR APPLICATION OR FIT FOR ANY PARTICULAR PURPOSE, OR WILL OPERATE IN YOUR IMPLEMENTATION. SILICON LABS AND ITS LICENSORS DO NOT WARRANT THAT THE DESIGN IMPLIED IN THIS SCHEMATIC IS PRODUCTION-WORTHY. YOU SHOULD COMPLETELY VALIDATE AND TEST YOUR DESIGN IMPLEMENTATION TO CONFIRM SYSTEM FUNCTIONALITY FOR YOUR APPLICATION.



Revision History	
Rev.	Description
A00	Initial version.
A01	Updated EFR32 chip revision and 32 kHz crystal part number.
A02	Fixing EFR32 pin names; Updated PCB revision.
A03	Updated EFR32 to Rev. C. Fixed 32 kHz crystal P/N.
A04	Fixed P/N for C5.

<Schematic Path>
SCHEMATIC1

		Schematic Title	
		EFR32MG12 Dual Band 2400/868 MHz Radio	
Designed: TAB Size: A3 Design Created Date: Monday, April 02, 2012		Page Title	
		Title Page	
BOM Doc No: <Cage Code> Design Created Date: Monday, April 02, 2012		Document number	Revision
		BRD4163A	A04
Sheet Created Date: Monday, April 02, 2012		Sheet Modified Date: Thursday, January 11, 2018	Sheet: 1 of 4

Antenna & Radio Interface

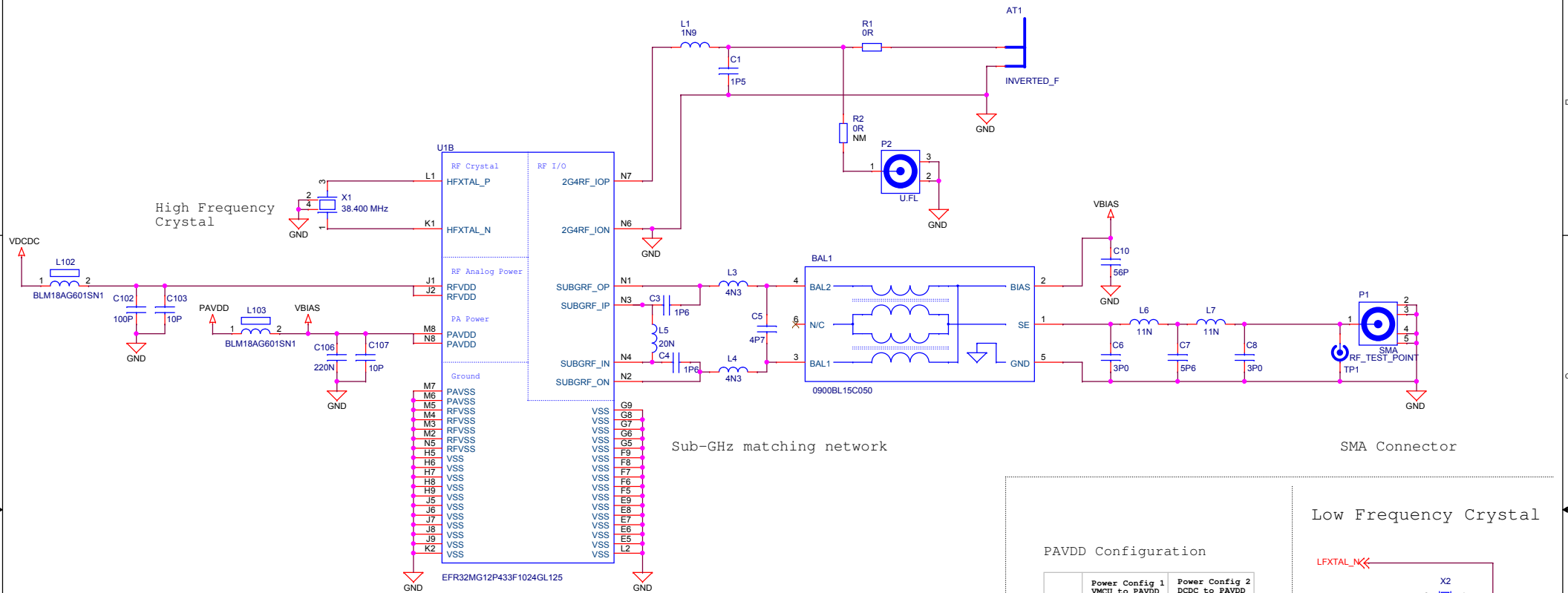

Power & Decoupling

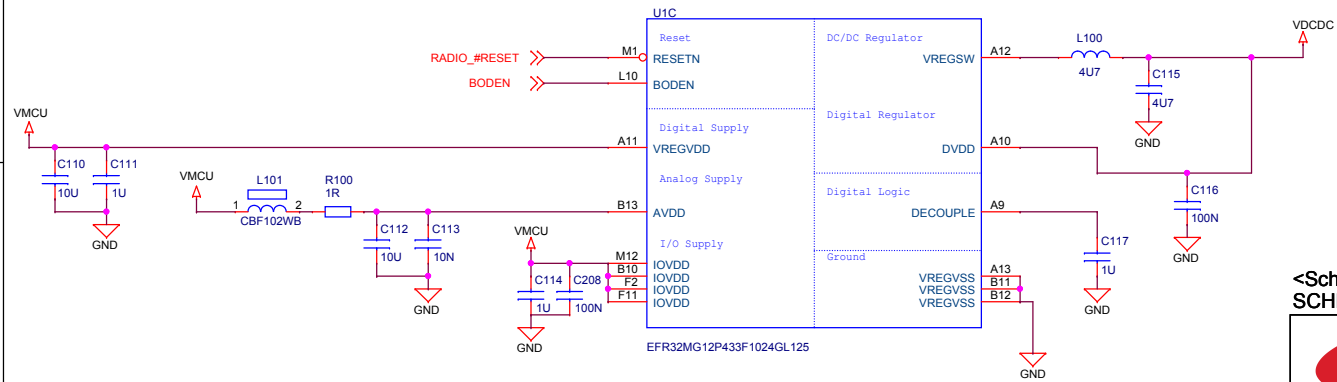

PAVDD Configuration

	Power Config 1 VMCU to PAVDD	Power Config 2 DCDC to PAVDD
R210	Mount	Not mount
R211	Not mount	Mount

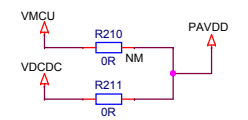

Low Frequency Crystal

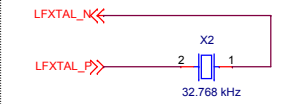

RF Shielding

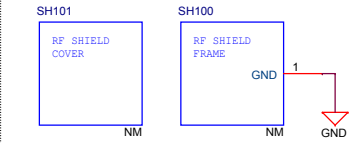

<Schematic Path>
SCHEMATIC1

<p>SILICON LABS</p>		Schematic Title	
		EFR32MG12 Dual Band 2400/868 MHz Radio Bo	
Designed: TAB		Page Title	
Approved: <OrgAddr2>		RF, Antenna & Power	
Size: A3	BOM Doc No: <Cage Code>	Document number	Revision
Design Created Date: Monday, April 02, 2012		BRD4163A	A04
Sheet Created Date: Monday, April 02, 2012	Sheet Modified Date: Thursday, January 11, 2018	Sheet 2 of 4	

EFR32 Pin Mapping

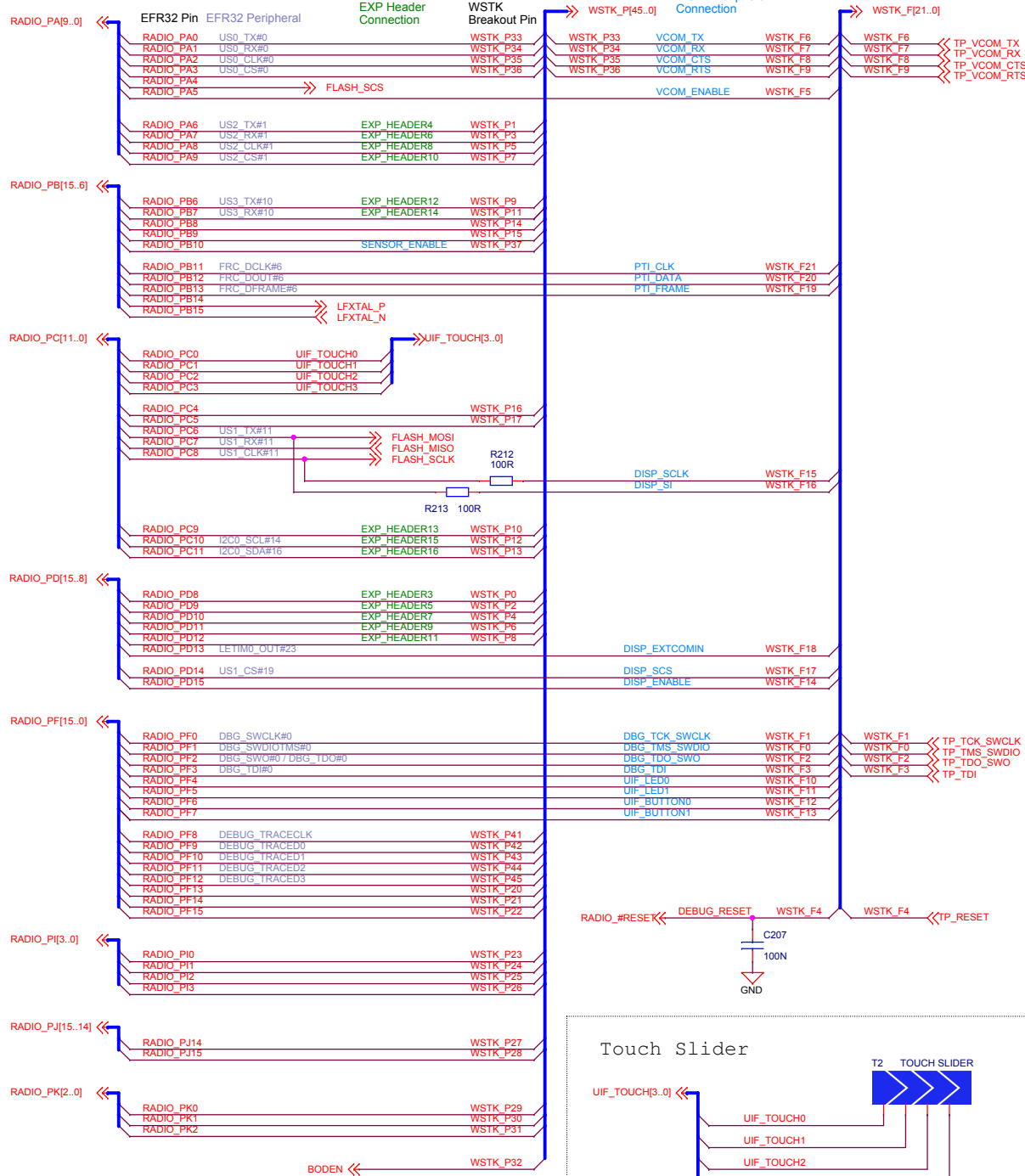

EFR32 I/O Port Pins

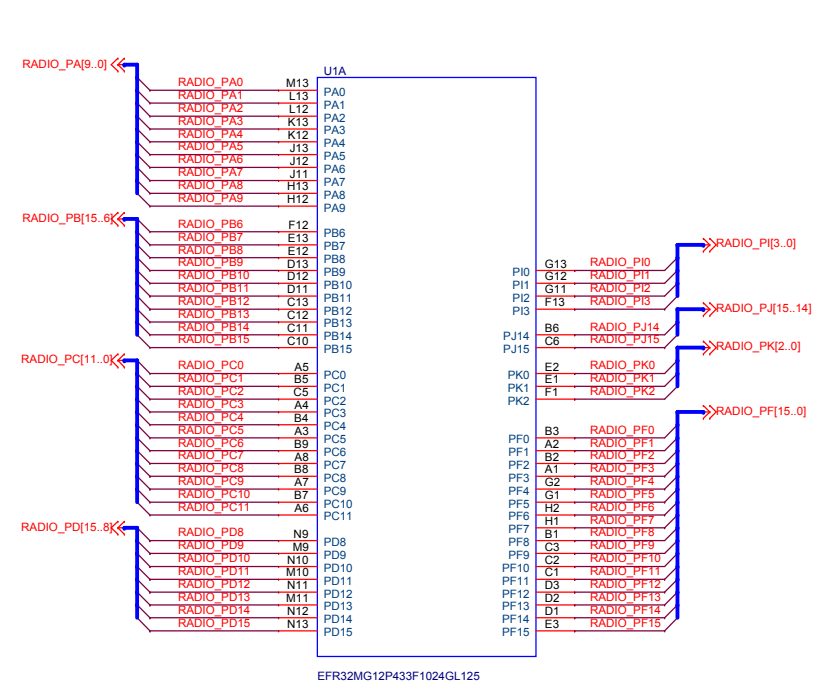

Serial Flash

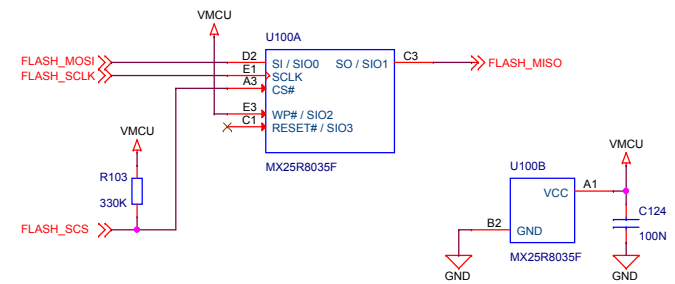

<Schematic Path> SCHEMATIC1

		Schematic Title	
		EFR32MG12 Dual Band 2400/868 MHz Radio Bo	
Designed: TAB Size: A3 Design Created Date: Monday, April 02, 2012		Page Title	
		EFR32 I/O Port Connections	
Approved: <OrgAddr2> BOM Doc No: <Cage Code>		Document number	Revision
		BRD4163A	A04
		Sheet Created Date	Sheet Modified Date
		Wednesday, April 11, 2012	Thursday, January 11, 2018
		Sheet	of 4
		3	4

WSTK Connectors

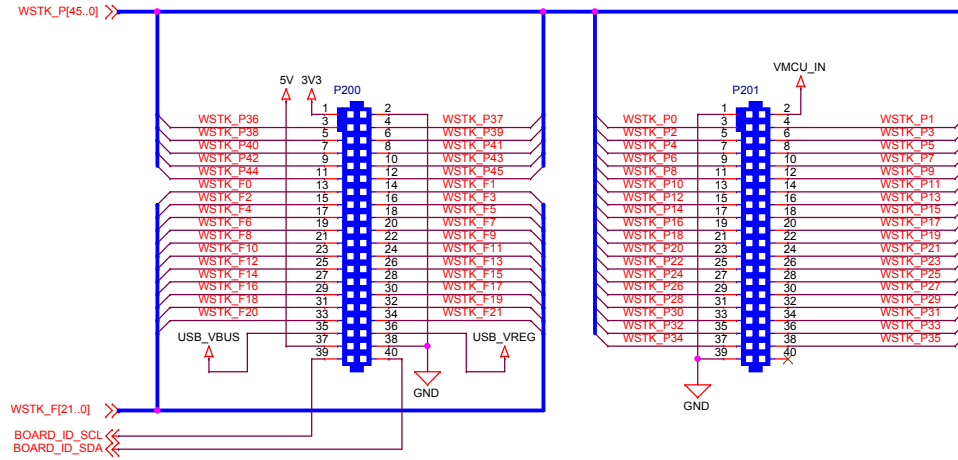

WSTK Power Decoupling

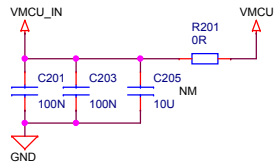

Board Identification

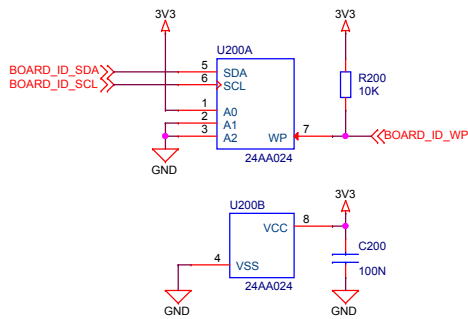

Test Points

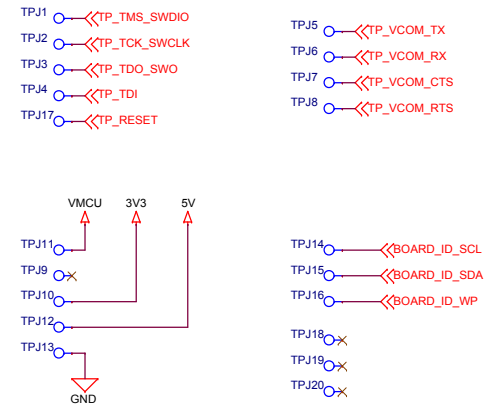

<Schematic Path>
SCHEMATIC1

		Schematic Title	
		EFR32MG12 Dual Band 2400/868 MHz Radio Board	
Designed: TAB Size: A3 Design Created Date: Monday, April 02, 2012		Page Title	
		WSTK Connectors & Board ID	
Approved: <OrgAddr2> BOM Doc No: <Cage Code>		Document number	
		BRD4163A	
Sheet Created Date: Tuesday, April 03, 2012		Sheet Modified Date: Thursday, January 11, 2018	
Revision: A04		Sheet 4 of 4	