



## EFR32 Mighty Gecko Radio Board

2.4 GHz / 868-915 MHz 19 dBm, VMCU to PAVDD

Board Function	Page
Title Page	1
RF, Antenna & Power	2
EFR32 Signal Assignments	3
WSTK Connectors & Board ID	4

LEGAL NOTICE:  
 SILICON LABORATORIES INC. ("SILICON LABS") AND/OR ITS LICENSORS DO NOT WARRANT THE ACCURACY OR COMPLETENESS OF THIS SCHEMATIC OR ANY INFORMATION CONTAINED WITHIN THIS SCHEMATIC. IT IS PROVIDED "AS-IS" FOR REFERENCE ONLY. SILICON LABS DOES NOT WARRANT THAT THIS DESIGN WILL MEET THE SPECIFICATIONS, BE SUITABLE FOR YOUR APPLICATION OR FIT FOR ANY PARTICULAR PURPOSE, OR WILL OPERATE IN YOUR IMPLEMENTATION. SILICON LABS AND ITS LICENSORS DO NOT WARRANT THAT THE DESIGN IMPLIED IN THIS SCHEMATIC IS PRODUCTION-WORTHY. YOU SHOULD COMPLETELY VALIDATE AND TEST YOUR DESIGN IMPLEMENTATION TO CONFIRM SYSTEM FUNCTIONALITY FOR YOUR APPLICATION.



Revision History	
Rev.	Description
A00	Initial revision.
A01	Updated U1 P/N.

<Schematic Path>  
SCHEMATIC1

		Schematic Title	
		<b>EFR32MG12 WSTK Radio Board</b>	
Designed: TAB Approved: DDB		Page Title	
		<b>Title Page</b>	
Size A3	BOM Doc No: <Cage Code>	Document number	Revision
Design Created Date: Monday, April 02, 2012		BRD4170A	A01
Sheet Created Date Monday, April 02, 2012		Sheet Modified Date Monday, November 19, 2018	Sheet 1 of 4

Antenna & Radio Interface

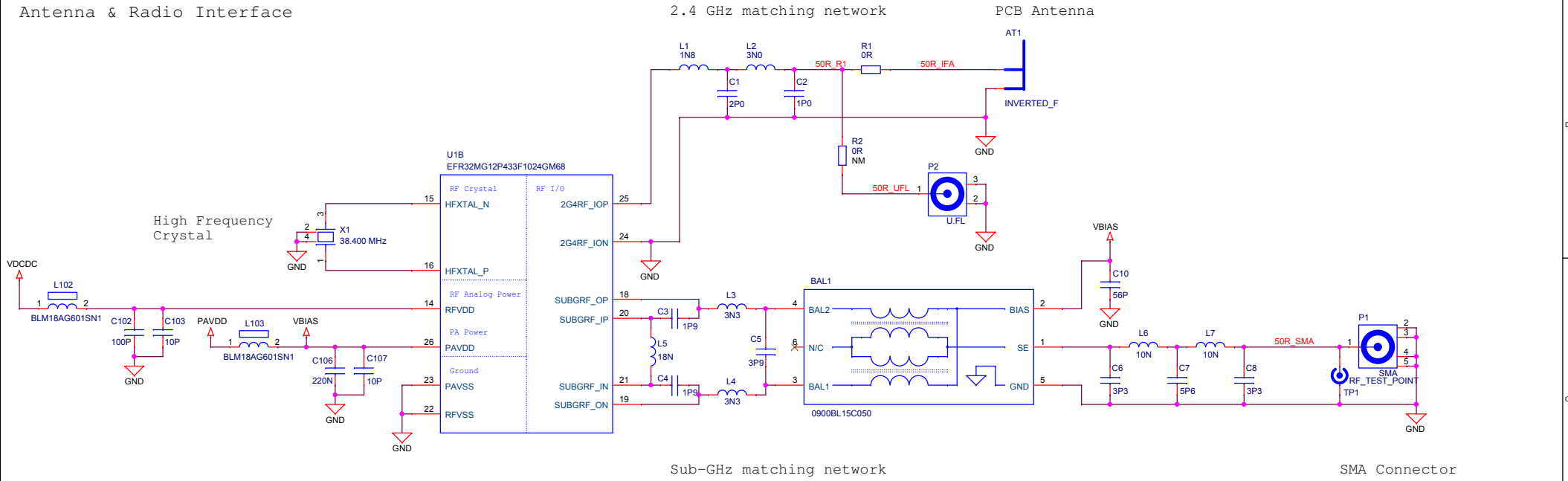

Power & Decoupling

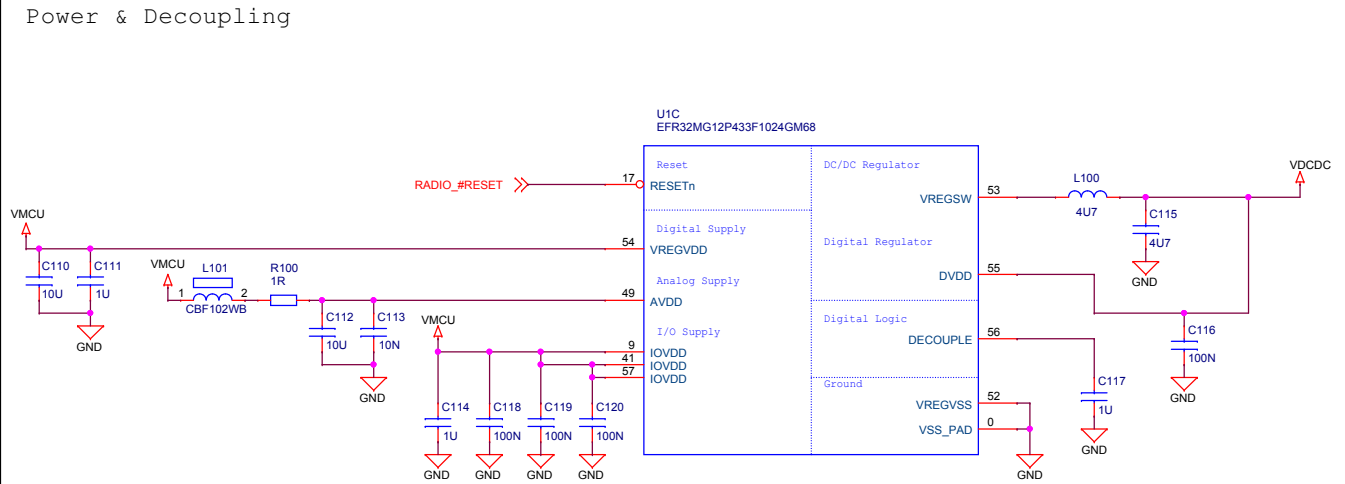

PAVDD Configuration

	Power Config 1 VMCU to PAVDD	Power Config 2 DCDC to PAVDD
R210	Mount	Not mount
R211	Not mount	Mount

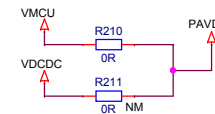

Low Frequency Crystal

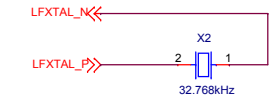

RF Shielding

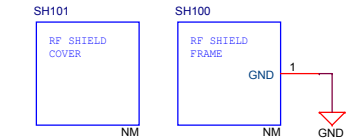

<Schematic Path>  
SCHEMATIC1

		Schematic Title	
		<b>EFR32MG12 WSTK Radio Board</b>	
Designed: TAB Approved: DDB		Page Title	
		<b>RF, Antenna &amp; Power</b>	
Size: A3	BOM Doc No: <Cage Code>	Document number	Revision
Design Created Date: Monday, April 02, 2012	Sheet Created Date: Monday, April 02, 2012	Document number: <b>BRD4170A</b>	Revision: <b>A01</b>
	Sheet Modified Date: Monday, November 19, 2018	Sheet 2 of 4	

# EFR32 Pin Mapping

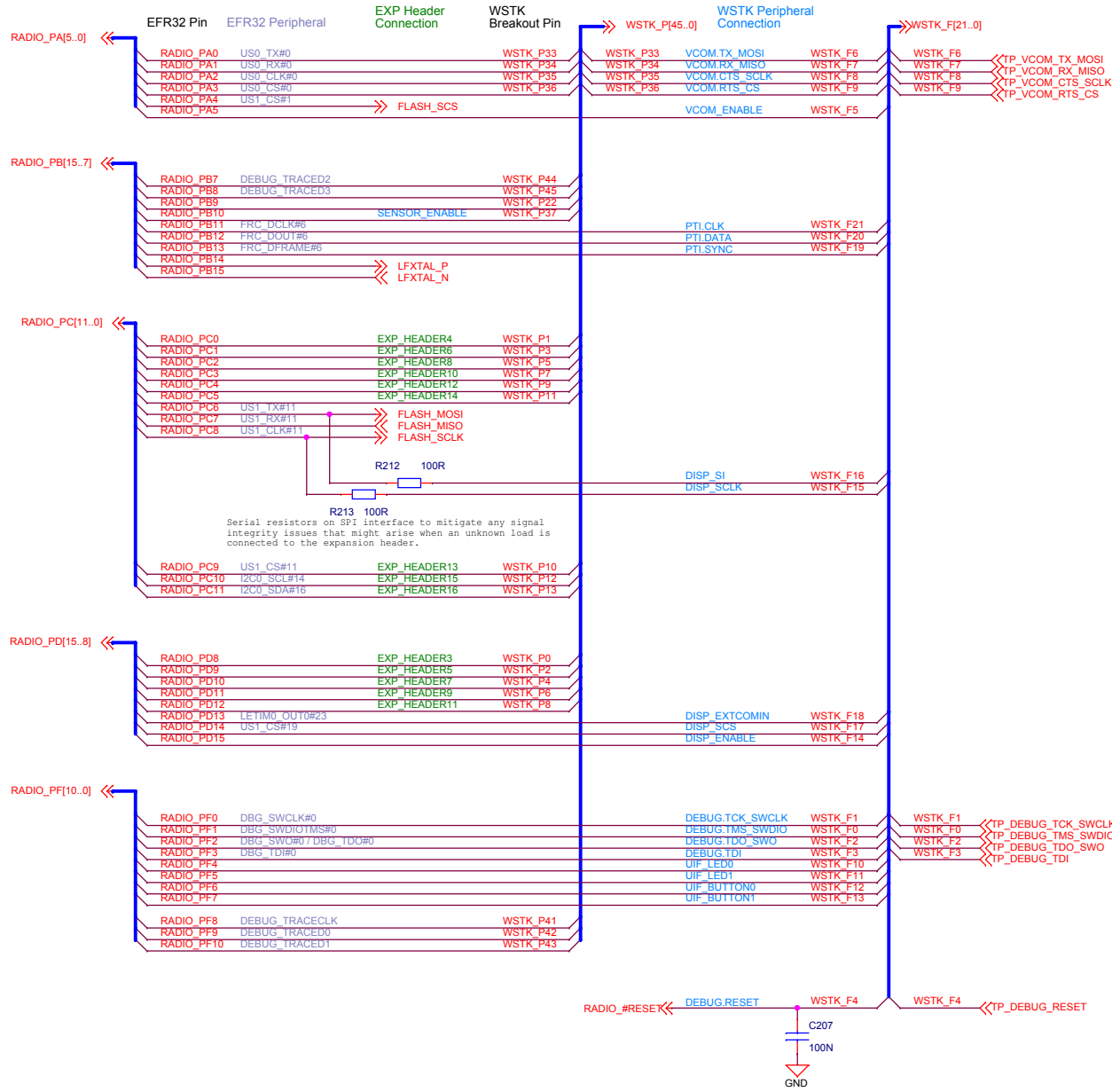

# EFR32 I/O Port Pins

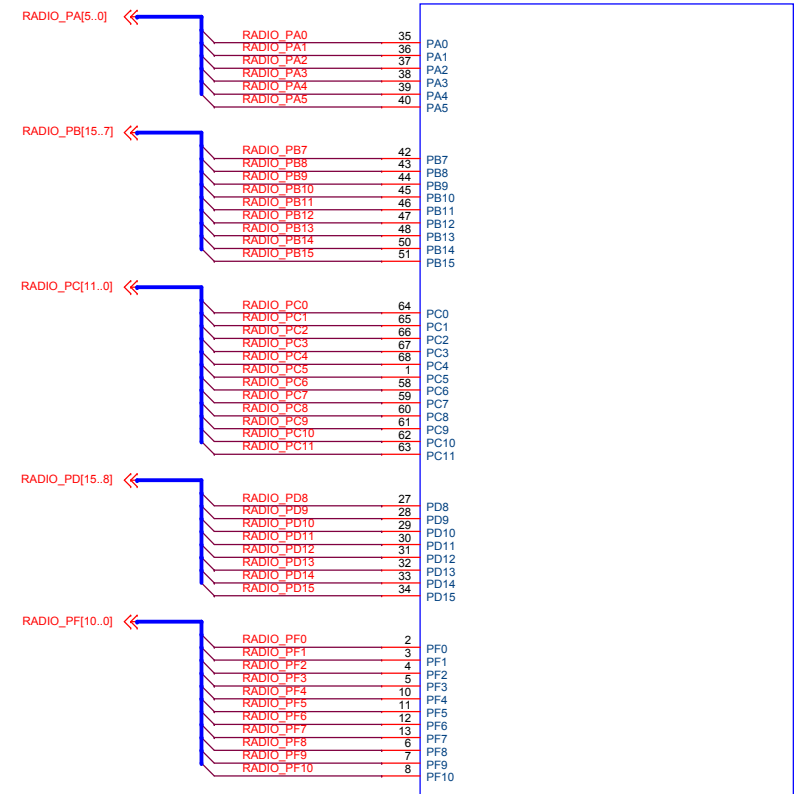

# Serial Flash

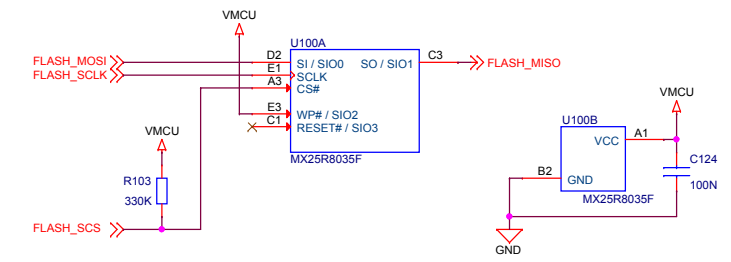

# <Schematic Path> SCHEMATIC1

		Schematic Title	
		<b>EFR32MG12 WSTK Radio Board</b>	
Designed: TAB Size: A3 Design Created Date: Monday, April 02, 2012		Page Title	
		<b>EFR32 I/O Port Connections</b>	
Approved: DDB BOM Doc No: <Cage Code>		Document number	Revision
		<b>BRD4170A</b>	<b>A01</b>
Sheet Created Date: Wednesday, April 11, 2012		Sheet Modified Date: Monday, November 19, 2018	Sheet 3 of 4

# WSTK Connectors

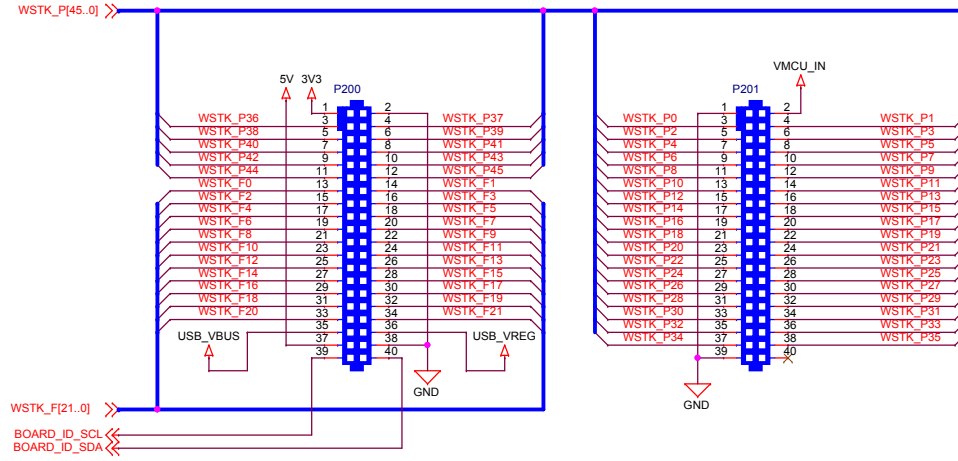

## WSTK Power Decoupling

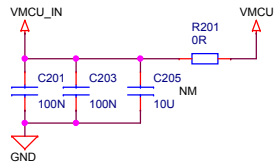

## Board Identification

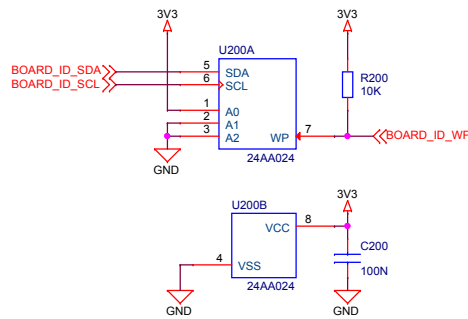

## Test Points

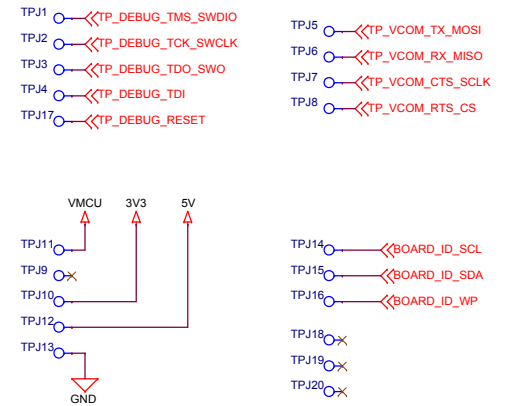

<Schematic Path>  
SCHEMATIC1

		Schematic Title	
		<b>EFR32MG12 WSTK Radio Board</b>	
Designed: TAB Size: A3 Design Created Date: Monday, April 02, 2012		Page Title	
		<b>WSTK Connectors &amp; Board ID</b>	
Approved: DDB BOM Doc No: <Cage Code>		Document number	Revision
Monday, April 02, 2012		<b>BRD4170A</b>	<b>A01</b>
Sheet Created Date: Tuesday, April 03, 2012		Sheet Modified Date: Monday, November 19, 2018	Sheet 4 of 4