

Antenna & Radio Interface

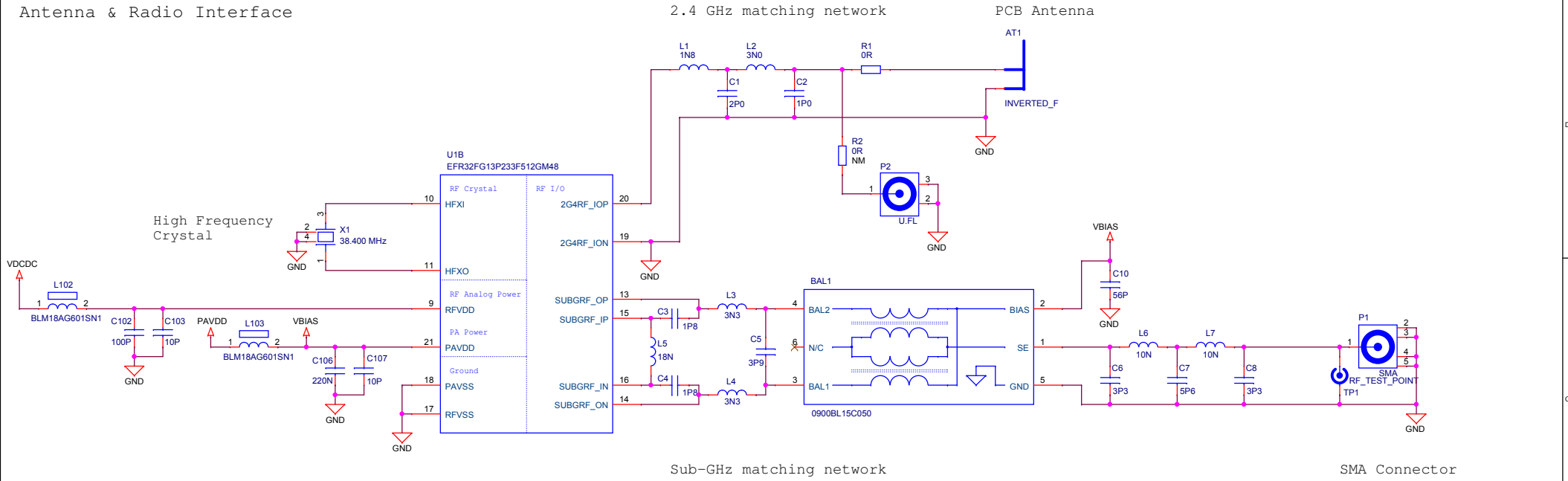

Power & Decoupling

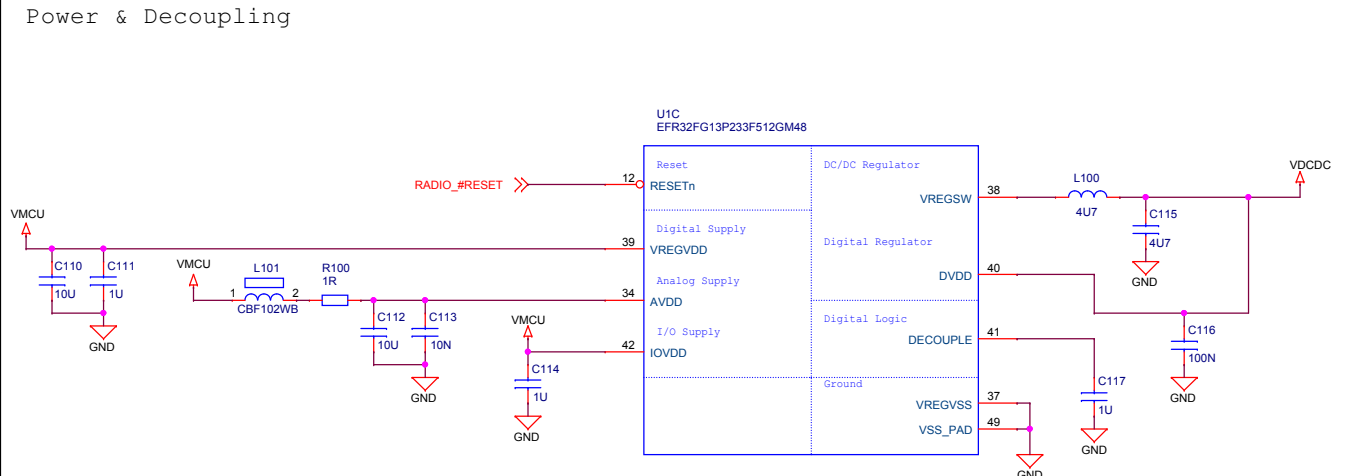

PAVDD Configuration

	Power Config 1 VMCU to PAVDD	Power Config 2 DCDC to PAVDD
R210	Mount	Not mount
R211	Not mount	Mount

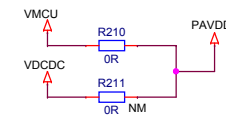

Low Frequency Crystal

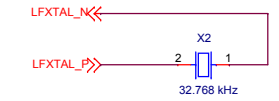

RF Shielding

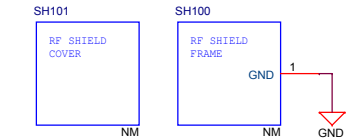

<Schematic Path>
SCHEMATIC1

		Schematic Title	
		EFR32FG13 Dual Band 2400/915 MHz Radio Boa	
Designed: JSH Approved: JNO		Page Title	
		RF, Antenna & Power	
Size: A3 BOM Doc No: <Cage Code>		Document number BRD4255A	
Design Created Date: Monday, April 02, 2012		Sheet Created Date Monday, April 02, 2012	
		Sheet Modified Date Friday, October 20, 2017	
		Revision A01	
		Sheet 2 of 4	

EFR32 Pin Mapping

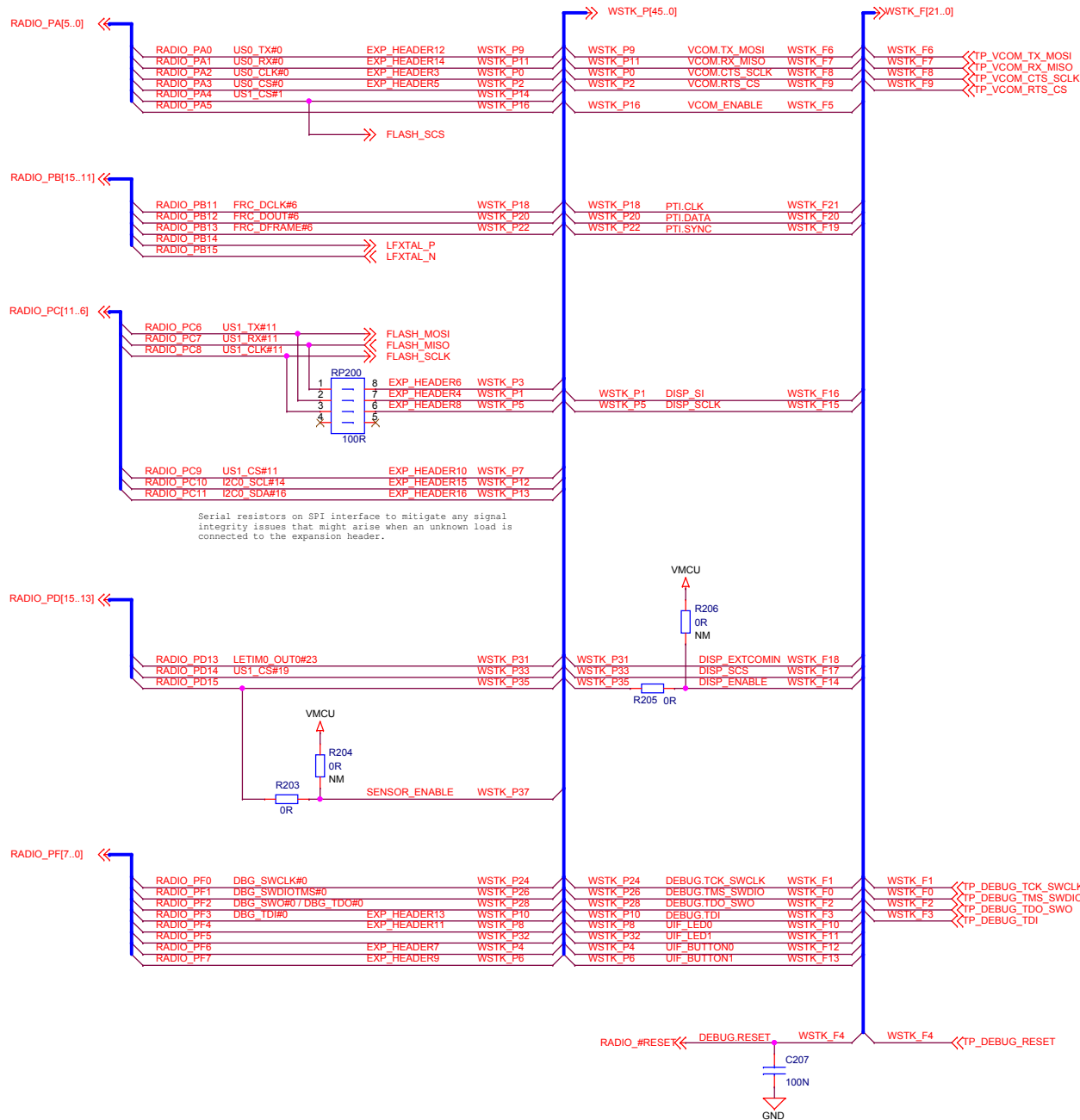

EFR32 I/O Port Pins

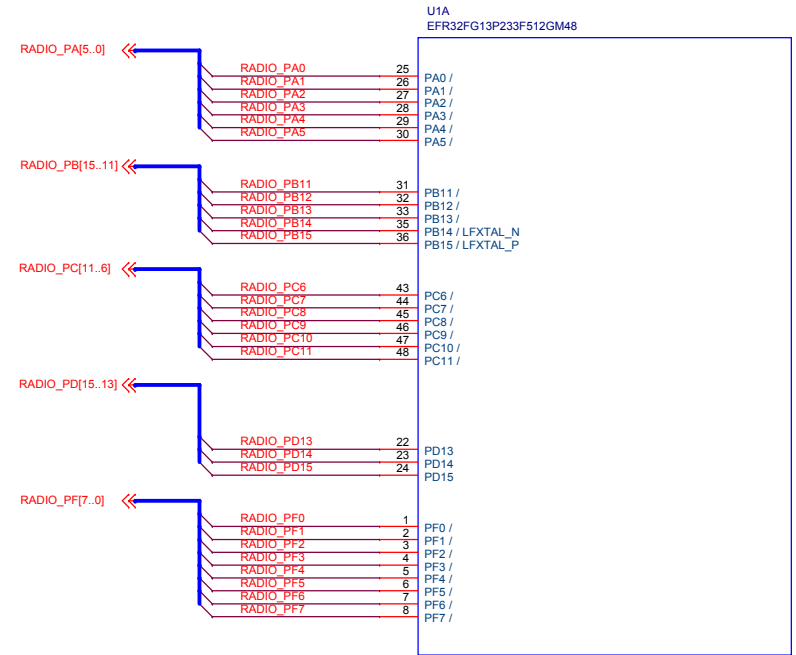

Serial Flash

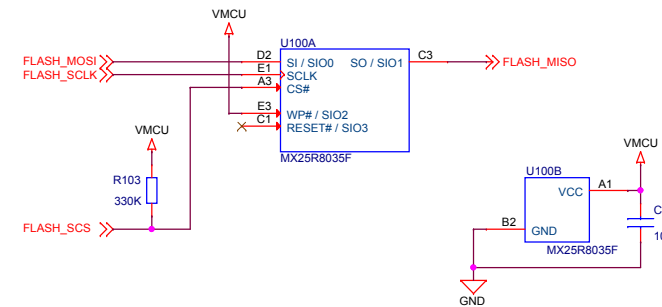

<Schematic Path>
SCHEMATIC1

		Schematic Title	
		EFR32FG13 Dual Band 2400/915 MHz Radio Boa	
Designed: JSH Approved: JNO		Page Title	
		EFR32 I/O Port Connections	
Size: A3 BOM Doc No: <Cage Code>		Document number BRD4255A	
Design Created Date: Monday, April 02, 2012		Sheet Created Date Wednesday, April 11, 2012	
		Sheet Modified Date Friday, October 20, 2017	
		Revision A01	
		Sheet 3 of 4	

WSTK Connectors

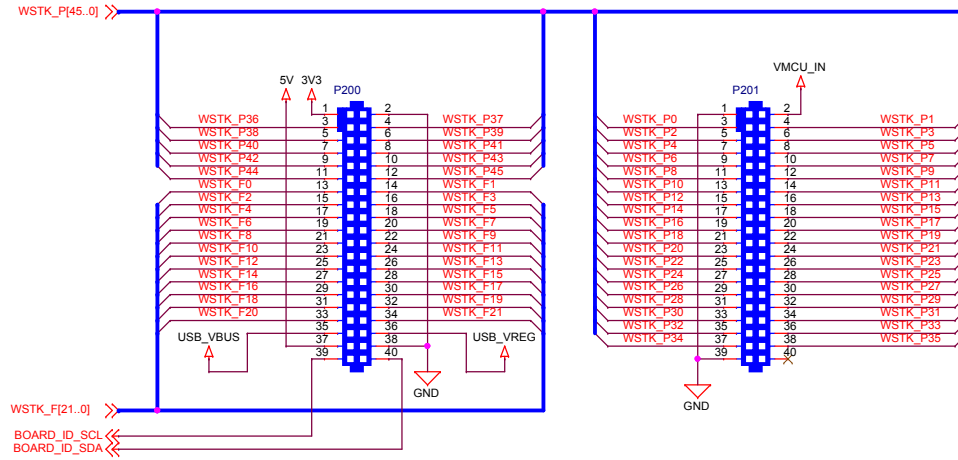

WSTK Power Decoupling

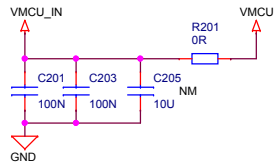

Board Identification

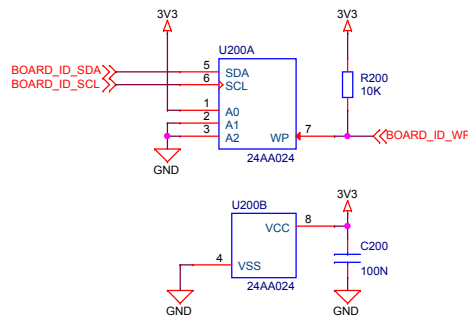

Test Points

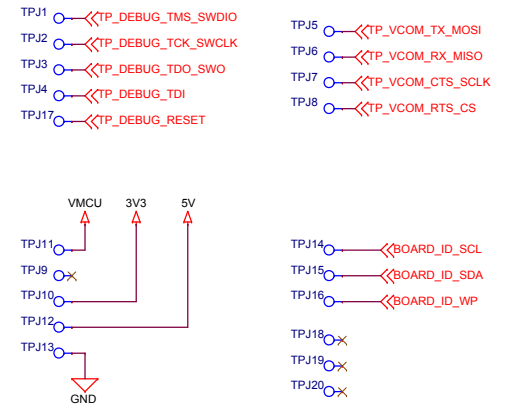

<Schematic Path>
SCHEMATIC1

		Schematic Title	
		EFR32FG13 Dual Band 2400/915 MHz Radio Boa	
Designed: JSH Approved: JNO		Page Title	
		WSTK Connectors & Board ID	
Size: A3	BOM Doc No: <Cage Code>	Document number	Revision
Design Created Date: Monday, April 02, 2012	Sheet Created Date: Tuesday, April 03, 2012	Document number: BRD4255A	Revision: A01
	Sheet Modified Date: Friday, October 20, 2017		Sheet 4 of 4