



## EFR32FG13 Dual Band Radio Board

2.4 GHz / 915 MHz 19 dBm, VMCU to PAVDD

Board Function	Page
Title Page	1
RF, Antenna & Power	2
EFR32 Signal Assignments	3
WSTK Connectors & Board ID	4

Revision History	
Rev.	Description
A00	Initial revision.
A01	Updated EFR32 revision to Rev. C. Fixing 32 kHz crystal P/N.
A02	Updated EFR32 revision to Rev. D.

LEGAL NOTICE:  
 SILICON LABORATORIES INC. ("SILICON LABS") AND/OR ITS LICENSORS DO NOT WARRANT THE ACCURACY OR COMPLETENESS OF THIS SCHEMATIC OR ANY INFORMATION CONTAINED WITHIN THIS SCHEMATIC. IT IS PROVIDED "AS-IS" FOR REFERENCE ONLY. SILICON LABS DOES NOT WARRANT THAT THIS DESIGN WILL MEET THE SPECIFICATIONS, BE SUITABLE FOR YOUR APPLICATION OR FIT FOR ANY PARTICULAR PURPOSE, OR WILL OPERATE IN YOUR IMPLEMENTATION. SILICON LABS AND ITS LICENSORS DO NOT WARRANT THAT THE DESIGN IMPLIED IN THIS SCHEMATIC IS PRODUCTION-WORTHY. YOU SHOULD COMPLETELY VALIDATE AND TEST YOUR DESIGN IMPLEMENTATION TO CONFIRM SYSTEM FUNCTIONALITY FOR YOUR APPLICATION.



<Schematic Path>  
 SCHEMATIC1

		Schematic Title	
		<b>EFR32FG13 Dual Band 2400/915 MHz Radio Bo</b>	
Designed: JSH Approved: JNO		Page Title	
		<b>Title Page</b>	
Size A3	BOM Doc No: <Cage Code>	Document number <b>BRD4255A</b>	Revision A02
Design Created Date: Monday, April 02, 2012		Sheet Created Date Monday, April 02, 2012	Sheet Modified Date Wednesday, May 15, 2019
		Sheet 1 of 4	

Antenna & Radio Interface

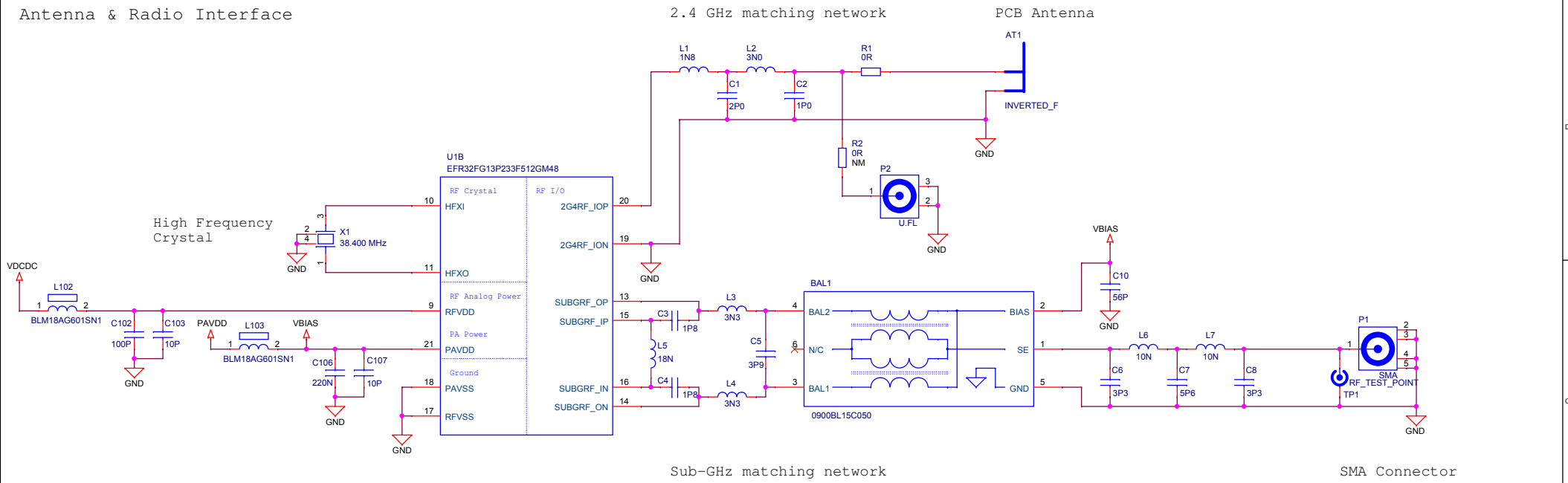

Power & Decoupling

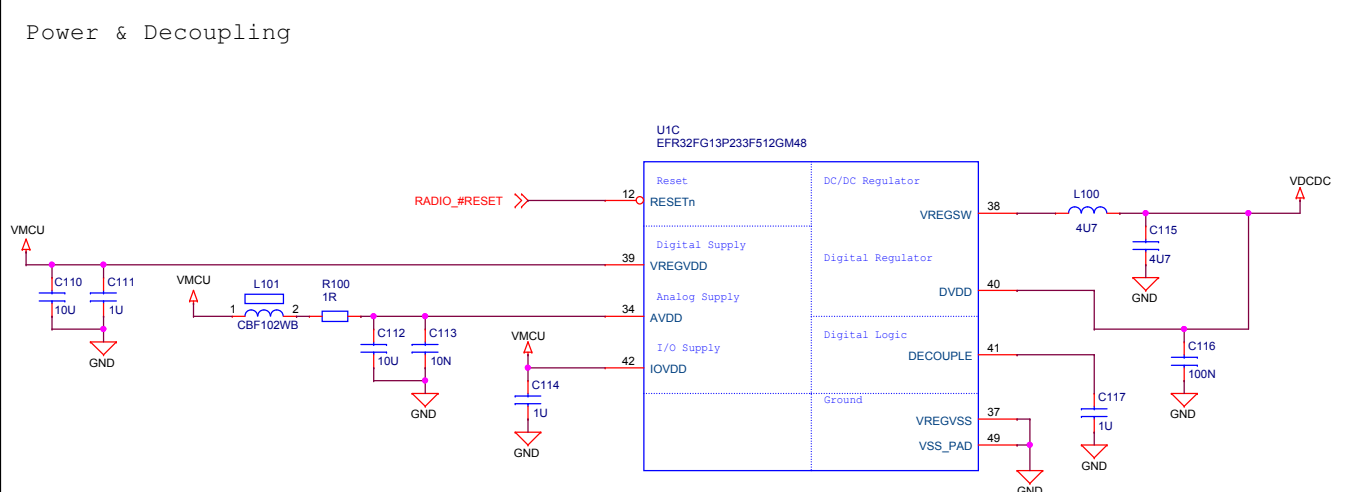

PAVDD Configuration

	Power Config 1 VMCU to PAVDD	Power Config 2 DCDC to PAVDD
R210	Mount	Not mount
R211	Not mount	Mount

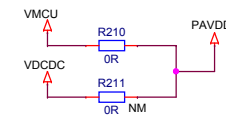

Low Frequency Crystal

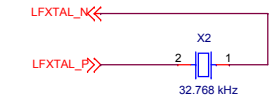

RF Shielding

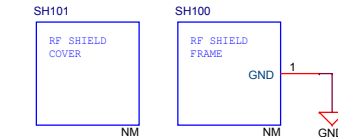

<Schematic Path>  
SCHEMATIC1

<p><b>SILICON LABS</b></p>	Schematic Title	
	<b>EFR32FG13 Dual Band 2400/915 MHz Radio Boa</b>	
Page Title		Revision
<b>RF, Antenna &amp; Power</b>		<b>A02</b>
Designed: JSH	Approved: JNO	Document number
Size A3	BOM Doc No: <Cage Code>	<b>BRD4255A</b>
Design Created Date: Monday, April 02, 2012	Sheet Created Date Monday, April 02, 2012	Sheet Modified Date Wednesday, May 15, 2019
		Sheet 2 of 4

# EFR32 Pin Mapping

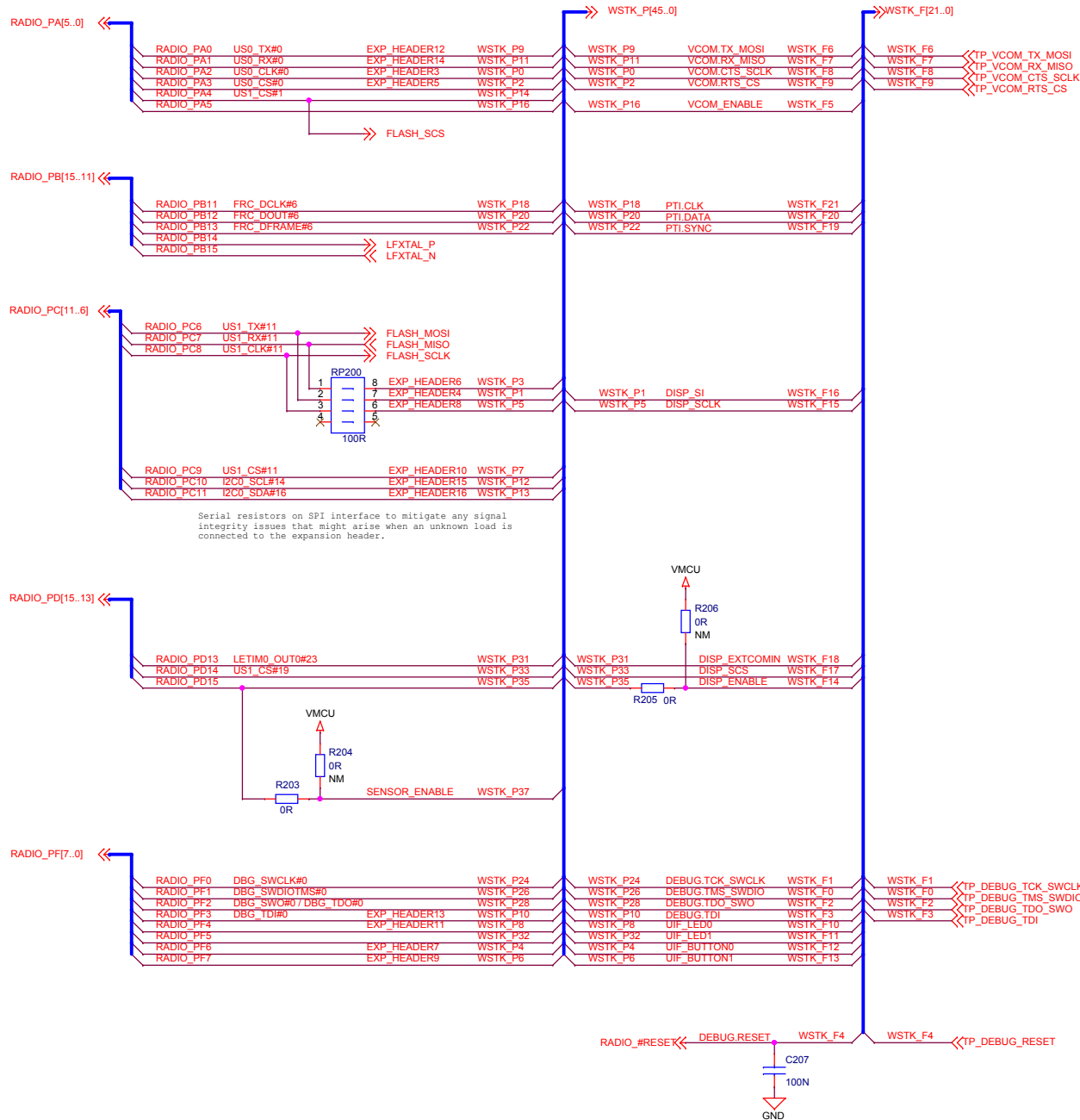

# EFR32 I/O Port Pins

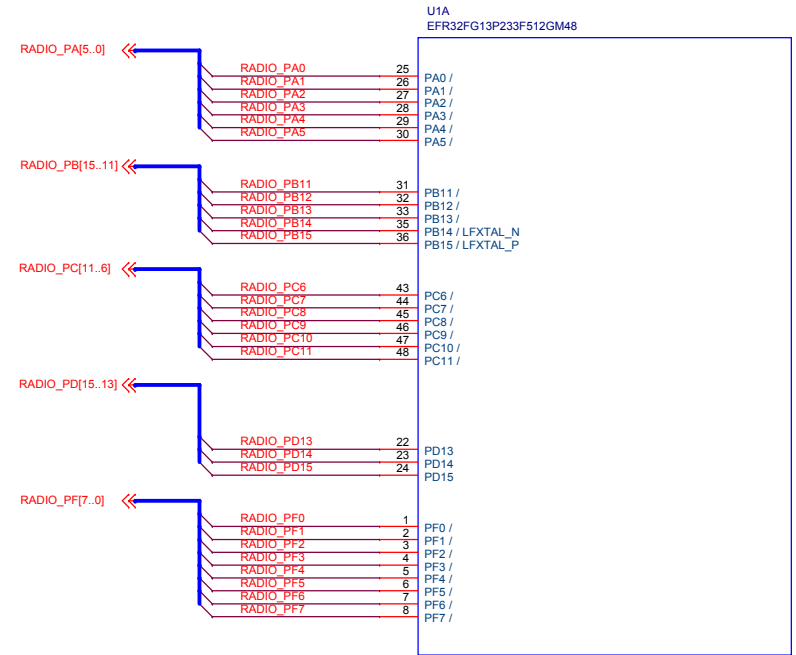

# Serial Flash

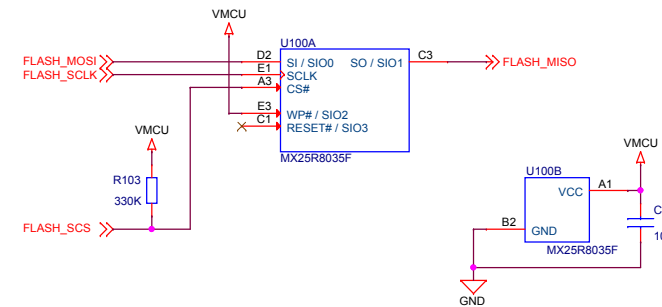

<Schematic Path>  
SCHEMATIC1

		Schematic Title	
		<b>EFR32FG13 Dual Band 2400/915 MHz Radio Boa</b>	
Designed: JSH Approved: JNO		Page Title	
		<b>EFR32 I/O Port Connections</b>	
Size: A3 BOM Doc No: <Cage Code>		Document number <b>BRD4255A</b>	
Design Created Date: Monday, April 02, 2012		Sheet Created Date Wednesday, April 11, 2012	
		Sheet Modified Date Wednesday, May 15, 2019	
		Revision <b>A02</b>	
		Sheet 3 of 4	

# WSTK Connectors

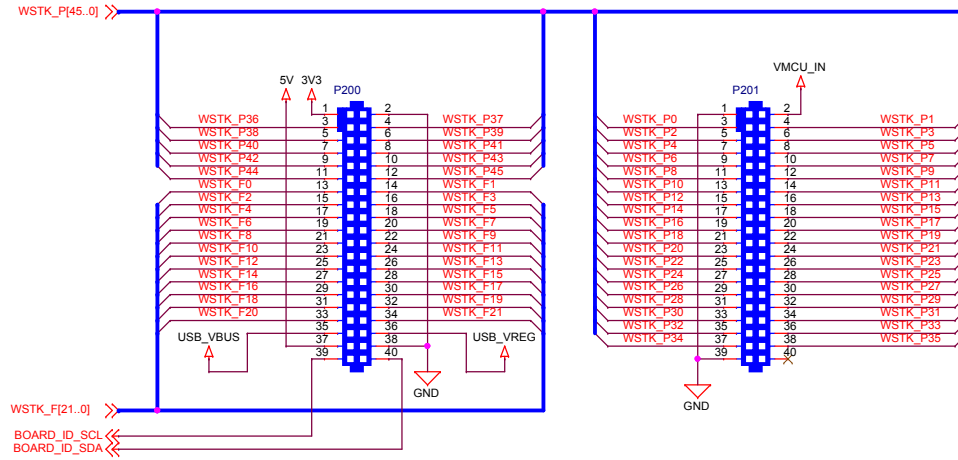

## WSTK Power Decoupling

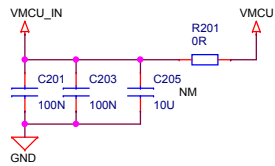

## Board Identification

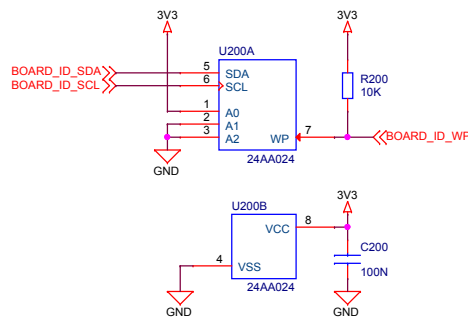

## Test Points

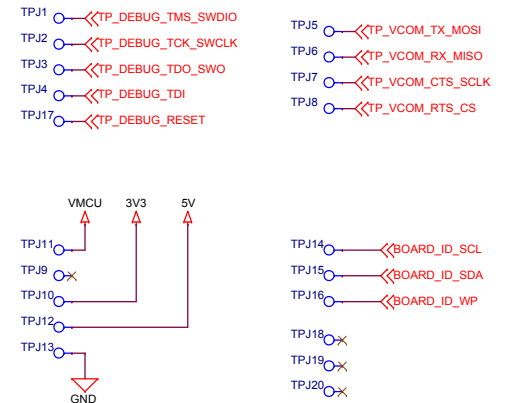

<Schematic Path>  
SCHEMATIC1

		Schematic Title	
		<b>EFR32FG13 Dual Band 2400/915 MHz Radio Boa</b>	
Designed: JSH Approved: JNO		Page Title	
		<b>WSTK Connectors &amp; Board ID</b>	
Size: A3	BOM Doc No: <Cage Code>	Document number	Revision
Design Created Date: Monday, April 02, 2012	Sheet Created Date: Tuesday, April 03, 2012	Document number: <b>BRD4255A</b>	Revision: <b>A02</b>
	Sheet Modified Date: Wednesday, May 15, 2019		Sheet 4 of 4