



EFR32FG14 Flex Gecko Radio Board

2.4 GHz / 434 MHz 10 dBm, VDCDC to PAVDD

Board Function	Page
Title Page	1
RF, Antenna & Power	2
EFR32 Signal Assignments	3
WSTK Connectors & Board ID	4

Revision History	
Rev.	Description
A00	Initial revision.
A01	Updating EFR revision to Rev. B.

LEGAL NOTICE:
 SILICON LABORATORIES INC. ("SILICON LABS") AND/OR ITS LICENSORS DO NOT WARRANT THE ACCURACY OR COMPLETENESS OF THIS SCHEMATIC OR ANY INFORMATION CONTAINED WITHIN THIS SCHEMATIC. IT IS PROVIDED "AS-IS" FOR REFERENCE ONLY. SILICON LABS DOES NOT WARRANT THAT THIS DESIGN WILL MEET THE SPECIFICATIONS, BE SUITABLE FOR YOUR APPLICATION OR FIT FOR ANY PARTICULAR PURPOSE, OR WILL OPERATE IN YOUR IMPLEMENTATION. SILICON LABS AND ITS LICENSORS DO NOT WARRANT THAT THE DESIGN IMPLIED IN THIS SCHEMATIC IS PRODUCTION-WORTHY. YOU SHOULD COMPLETELY VALIDATE AND TEST YOUR DESIGN IMPLEMENTATION TO CONFIRM SYSTEM FUNCTIONALITY FOR YOUR APPLICATION.



<Schematic Path>
 SCHEMATIC1

		Schematic Title	
		EFR32FG14 2.4 GHz / 434 MHz 10 dBm Radio B	
Designed: JSH Approved: JNO		Page Title	
		Title Page	
Size A3	BOM Doc No: <Cage Code>	Document number	Revision
Design Created Date: Monday, April 02, 2012		BRD4259A	A01
Sheet Created Date Monday, April 02, 2012		Sheet Modified Date Tuesday, August 29, 2017	Sheet 1 of 4

Antenna & Radio Interface

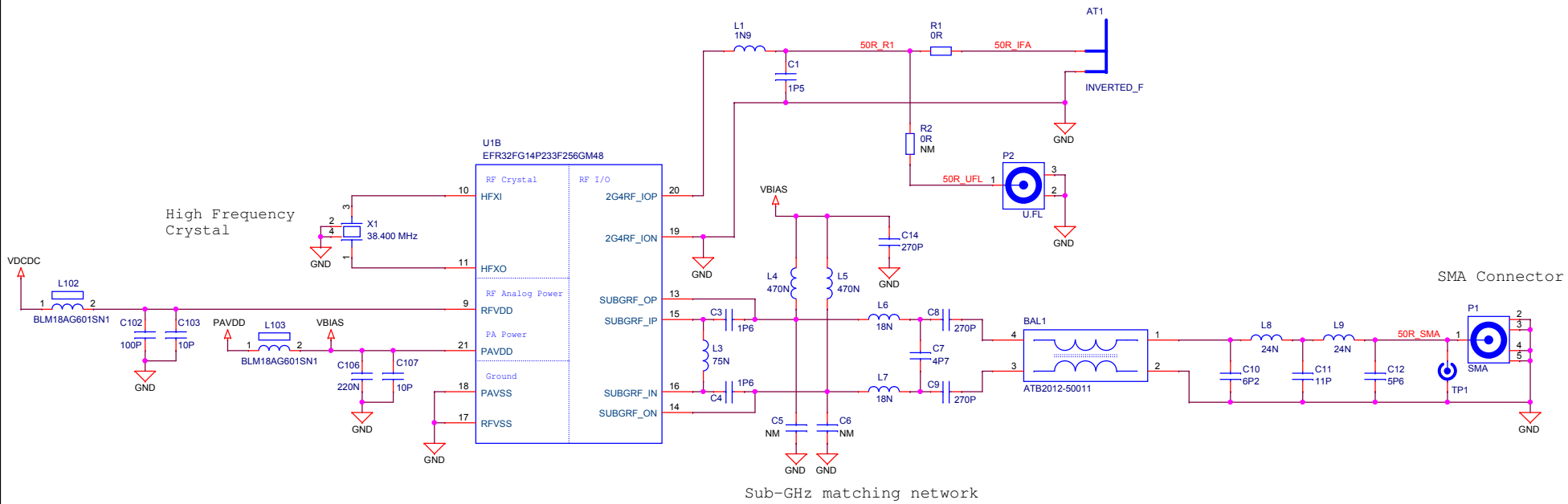

Power & Decoupling

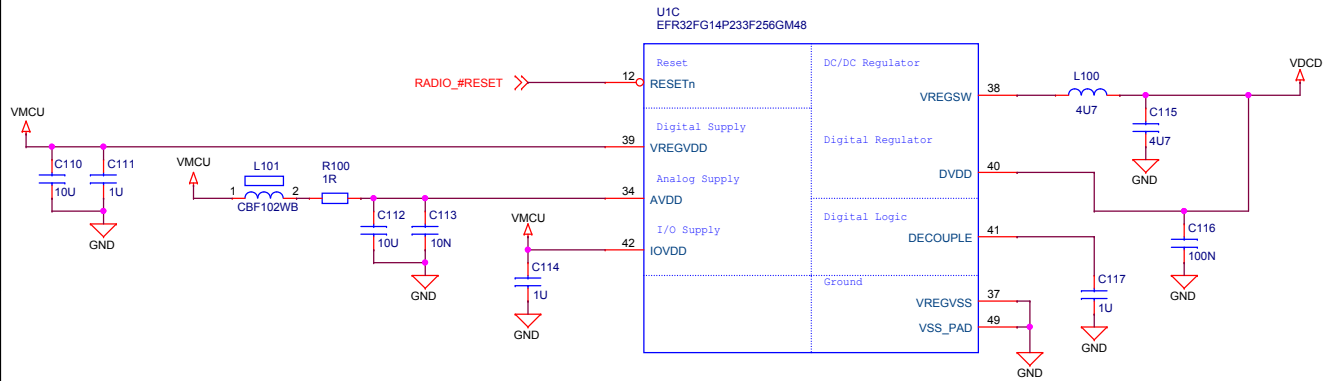

PAVDD Configuration

	Power Config 1 VMCU to PAVDD	Power Config 2 DCDC to PAVDD
R210	Mount	Not mount
R211	Not mount	Mount

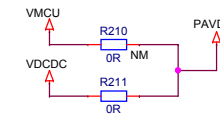

Low Frequency Crystal

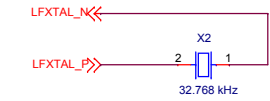

RF Shielding

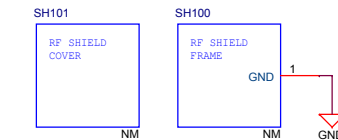

<Schematic Path>
SCHEMATIC1

		Schematic Title	
		EFR32FG14 2.4 GHz / 434 MHz 10 dBm Radio Bc	
Designed: JSH Approved: JNO		Page Title	
		RF, Antenna & Power	
Size: A3	BOM Doc No: <Cage Code>	Document number	Revision
Design Created Date: Monday, April 02, 2012	Sheet Created Date: Monday, April 02, 2012	Document number: BRD4259A	Revision: A01
	Sheet Modified Date: Tuesday, August 29, 2017		Sheet 2 of 4

EFR32 Pin Mapping

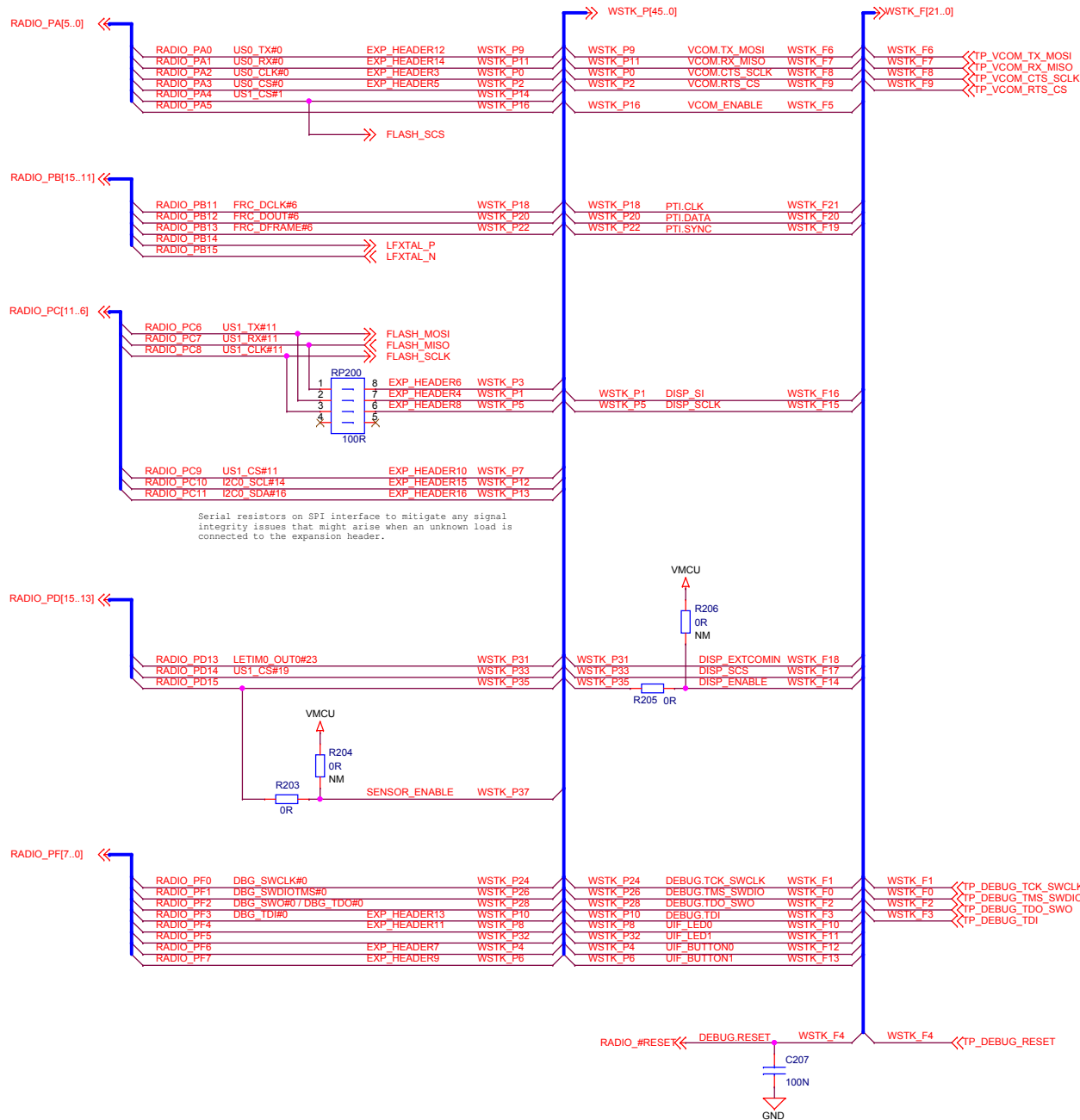

EFR32 I/O Port Pins

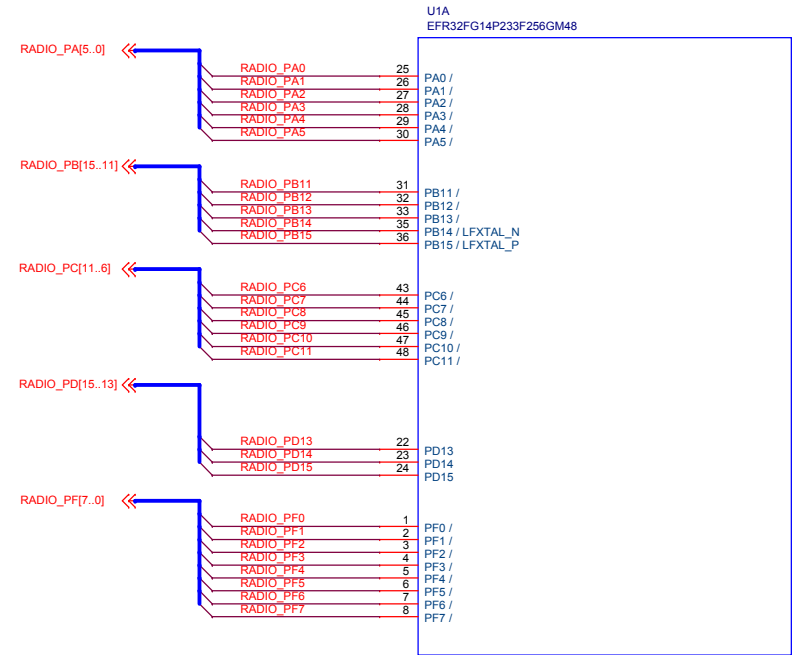

Serial Flash

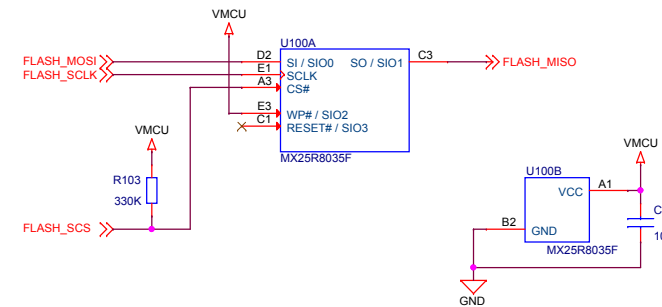

<Schematic Path> SCHEMATIC1

		Schematic Title	
		EFR32FG14 2.4 GHz / 434 MHz 10 dBm Radio Bc	
Designed: JSH Approved: JNO		Page Title	
		EFR32 I/O Port Connections	
Size: A3	BOM Doc No: <Cage Code>	Document number	Revision
Design Created Date: Monday, April 02, 2012	Sheet Created Date: Wednesday, April 11, 2012	BRD4259A	A01
	Sheet Modified Date: Tuesday, August 29, 2017		Sheet 3 of 4

WSTK Connectors

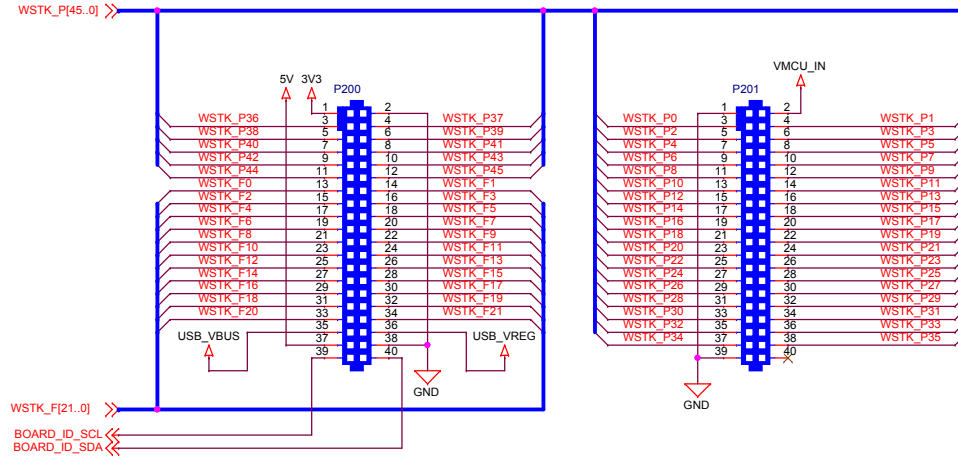

WSTK Power Decoupling

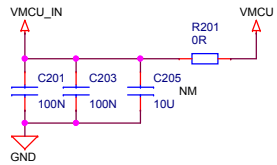

Board Identification

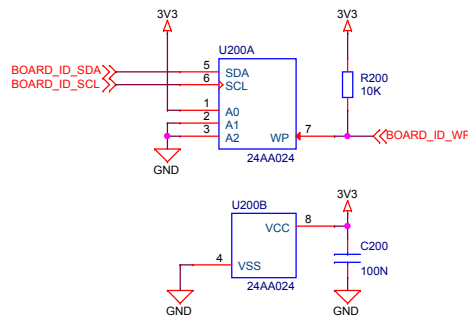

Test Points

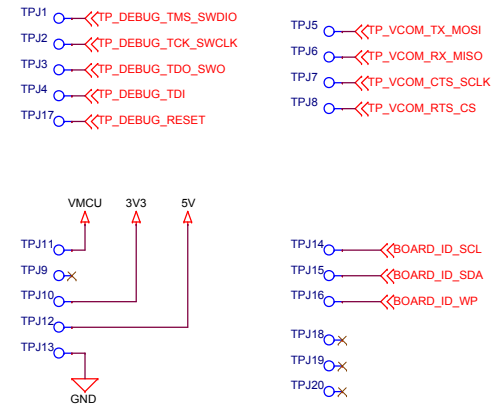

<Schematic Path>
SCHEMATIC1

 SILICON LABS		Schematic Title	
		EFR32FG14 2.4 GHz / 434 MHz 10 dBm Radio Bc	
Designed: JSH Approved: JNO		Page Title	
		WSTK Connectors & Board ID	
Size: A3	BOM Doc No: <Cage Code>	Document number	Revision
Design Created Date: Monday, April 02, 2012	Sheet Created Date: Tuesday, April 03, 2012	Document number: BRD4259A	Revision: A01
	Sheet Modified Date: Tuesday, August 29, 2017		Sheet 4 of 4