



**MGM220PC22 Wireless Gecko Module
Wireless Starter Kit Radio Board**

Board Function	Page
Title Page	1
Module Pin Assignments	2
WSTK Connectors & Board ID	3

Revision History

Rev.	Description
A00	Initial production release.
A01	Updated PCB silkscreen, variant ID, schematic file.
A02	Updated P200, P201, U200 OPNs.



LEGAL NOTICE:
SILICON LABORATORIES INC. ("SILICON LABS") AND/OR ITS LICENSORS DO NOT WARRANT THE ACCURACY OR COMPLETENESS OF THIS SCHEMATIC OR ANY INFORMATION CONTAINED WITHIN THIS SCHEMATIC. IT IS PROVIDED "AS-IS" FOR REFERENCE ONLY. SILICON LABS DOES NOT WARRANT THAT THIS DESIGN WILL MEET THE SPECIFICATIONS, BE SUITABLE FOR YOUR APPLICATION OR FIT FOR ANY PARTICULAR PURPOSE, OR WILL OPERATE IN YOUR IMPLEMENTATION. SILICON LABS AND ITS LICENSORS DO NOT WARRANT THAT THE DESIGN IMPLIED IN THIS SCHEMATIC IS PRODUCTION-WORTHY. YOU SHOULD COMPLETELY VALIDATE AND TEST YOUR DESIGN IMPLEMENTATION TO CONFIRM SYSTEM FUNCTIONALITY FOR YOUR APPLICATION.

 SILICON LABS		Board Name	
		MGM220PC22 Wireless Gecko Module Radio Board	
Designed TAB		Page Title	
		Title Page	
Approved JSH		Board Number	
BRD4311B		Revision	
Size	Sheet Modified Date	Revision	
A3	Saturday, April 10, 2021	A02	
COPYRIGHT SILICON LABORATORIES INC. 2020		CONFIDENTIAL – SUBJECT TO TERMS OF USE	
		Sheet 1 of 3	

Module Pin Mapping

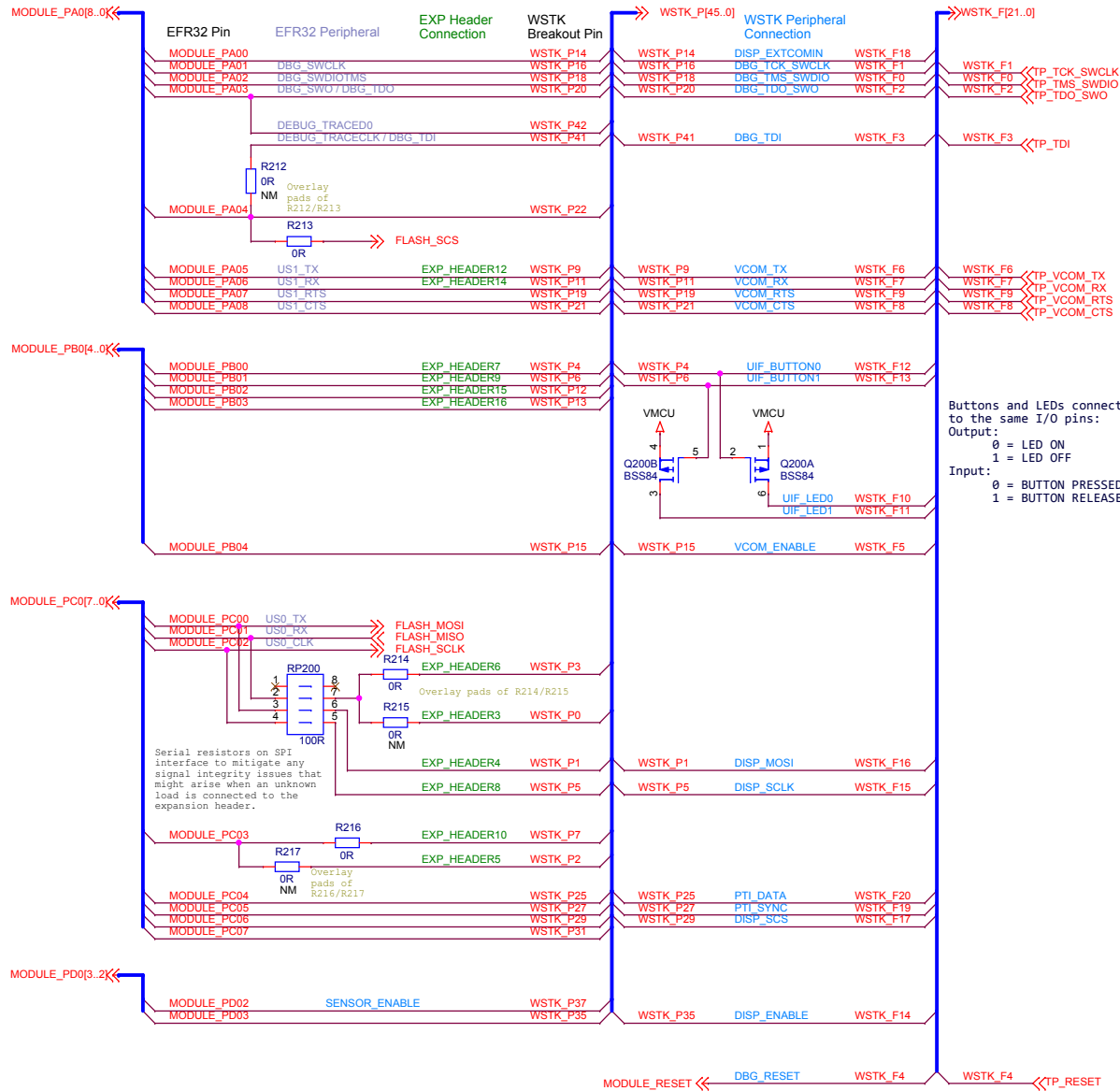

Module Footprint

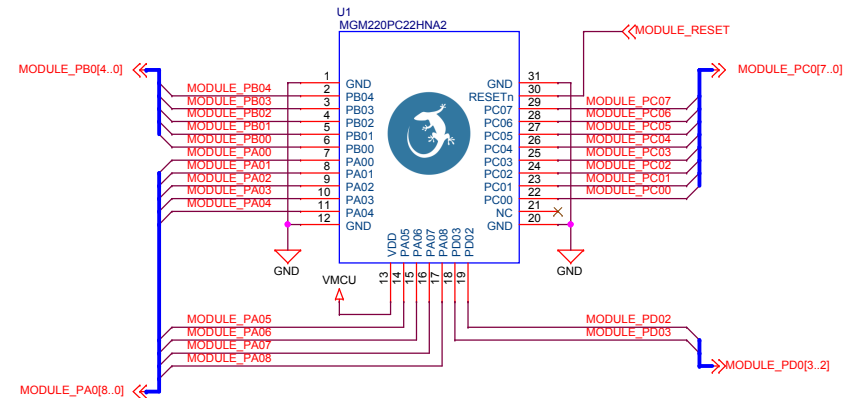

Serial Flash

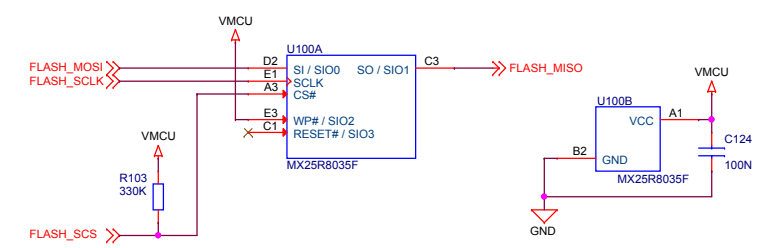

		Board Name	
		MGM220PC22 Wireless Gecko Module Radio Board	
Designed TAB		Page Title	
		Module Pin Assignments	
Approved JSH		Board Number	
Size A3		Sheet Modified Date Saturday, April 10, 2021	
		Board Number BRD4311B	
		Revision A02	
COPYRIGHT SILICON LABORATORIES INC. 2020 CONFIDENTIAL – SUBJECT TO TERMS OF USE			
Sheet 2 of 3			

WSTK Connectors

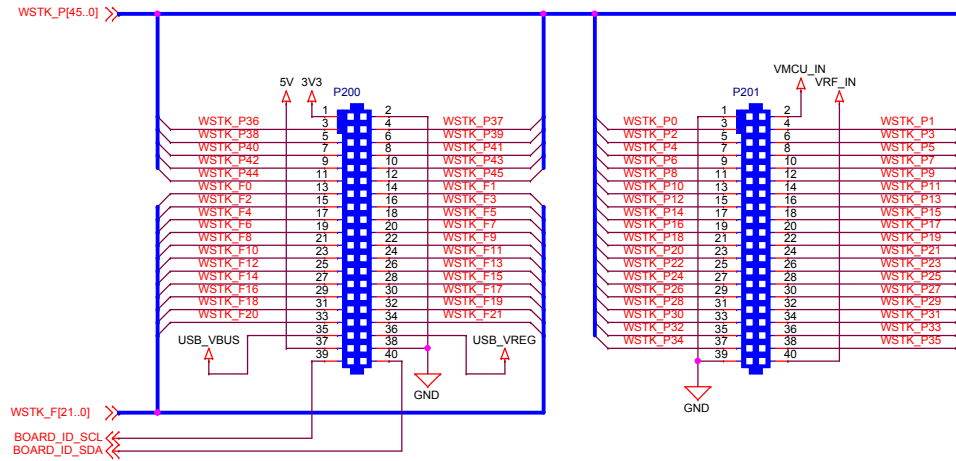

WSTK Power Decoupling

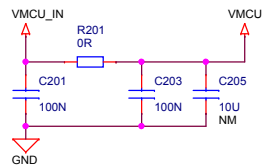

Board Identification

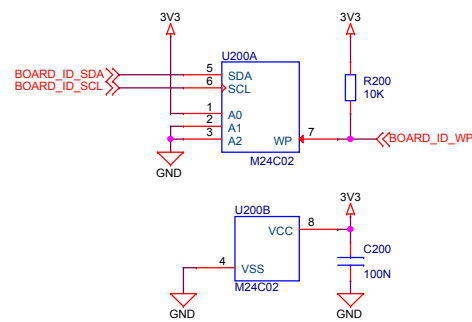

Test Points

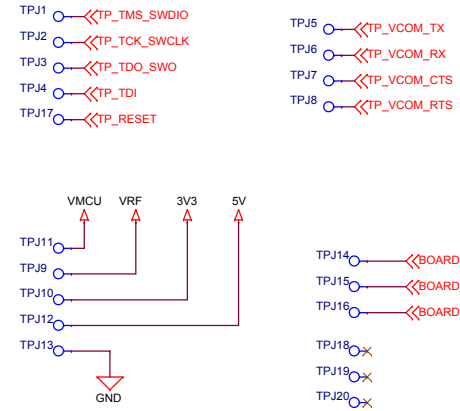

		Board Name	
		MGM220PC22 Wireless Gecko Module Radio Board	
Designed TAB		Page Title	
		WSTK Connectors & Board ID	
Approved JSH		Board Number	Revision
Size A3	Sheet Modified Date Saturday, April 10, 2021	BRD4311B	A02
COPYRIGHT SILICON LABORATORIES INC. 2020 CONFIDENTIAL – SUBJECT TO TERMS OF USE			Sheet 3 of 3