



EFM8LB1 Laser Bee STK	
Board Function	Page
Title Page	1
User Interfaces	2
Signal Assignments	3
EFM8 I/O & Power	4
STK Common Platform	5
1 kHz Signal Generator	6
Advanced Energy Monitor	7
Board Controller	8
Debug Interface	9
Power & Misc.	10

Revision History	
Rev.	Description
A00	Initial release.
A01	Changed to surface mounted joystick and smaller reset switch.
A02	Cleaned up sine generator circuit. Updated silk print.
A03	Updated revision on EFM8LB1. Moved reset switch. Update: Fixed EXP pinout description (documentation update change only)

LEGAL NOTICE:
SILICON LABORATORIES INC. ("SILICON LABS") AND/OR ITS LICENSORS DO NOT WARRANT THE ACCURACY OR COMPLETENESS OF THIS SCHEMATIC OR ANY INFORMATION CONTAINED WITHIN THIS SCHEMATIC. IT IS PROVIDED "AS-IS" FOR REFERENCE ONLY. SILICON LABS DOES NOT WARRANT THAT THIS DESIGN WILL MEET THE SPECIFICATIONS, BE SUITABLE FOR YOUR APPLICATION OR FIT FOR ANY PARTICULAR PURPOSE, OR WILL OPERATE IN YOUR IMPLEMENTATION. SILICON LABS AND ITS LICENSORS DO NOT WARRANT THAT THE DESIGN IMPLIED IN THIS SCHEMATIC IS PRODUCTION-WORTHY. YOU SHOULD COMPLETELY VALIDATE AND TEST YOUR DESIGN IMPLEMENTATION TO CONFIRM SYSTEM FUNCTIONALITY FOR YOUR APPLICATION.



STK		Schematic Title	
 SILICON LABS		EFM8LB1 Laser Bee Starter Kit	
Page Title		Title Page	
Designed: MRW	Approved: JNO	Document number	Revision
Size: A3	BOM Doc No:	BRD5300A	A03
Design Created Date: Wednesday, December 03, 2008	Sheet Created Date: Thursday, May 15, 2014	Sheet Modified Date: Monday, April 24, 2017	Sheet 1 of 10

5 Breakout Connections

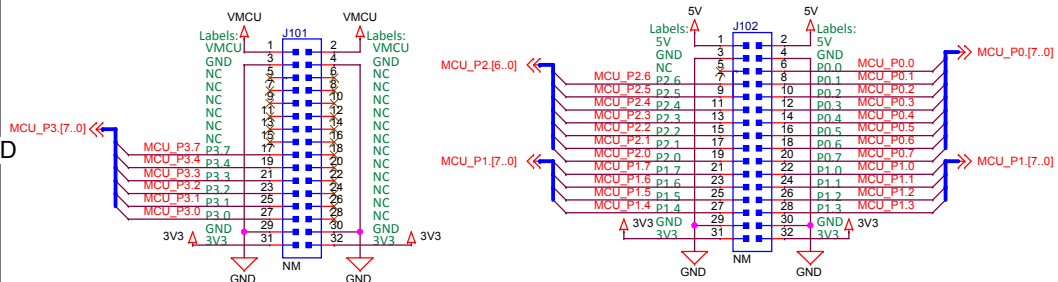

3 RGB LED

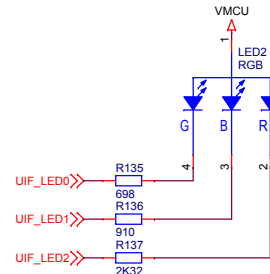

2 Analog Joystick

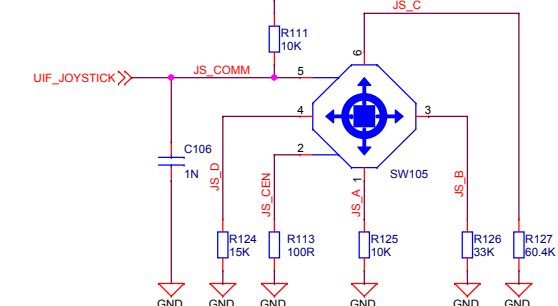

EXP port

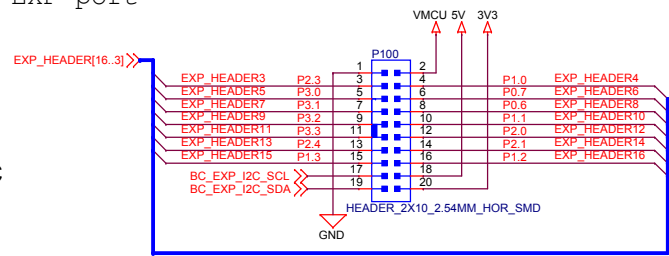

EXP-Header Functionality

1	GND		CMP1.5/ADC0.16
3	P2.3		DAC0
5	P3.0		DAC1
7	P3.1		DAC2
9	P3.2		DAC3
11	P3.3		CMP1.6/ADC0.17
13	P2.4		P1.3
15	P1.3		I2C0_SCL
17			Reserved for EXP Board Identification
19			Reserved for EXP Board Identification
2	VMCU		
4	P1.0	SPI0_MOSI	CMP1.1/ADC0.6
6	P0.7	SPI0_MISO	CMP0.5/ADC0.5
8	P0.6	SPI0_SCK	CMP0.4/ADC0.5
10	P1.1	SPI0_NSS	CMP0.7/ADC0.7
12	P2.0	UART1_TX	CMP1.3/ADC0.14
14	P2.1	UART1_RX	CMP1.4/ADC0.15
16	P1.2	I2C0_SDA	CMP0.8/ADC0.8
18	5V		
20	3V3		

U.F.L. ADC Connection

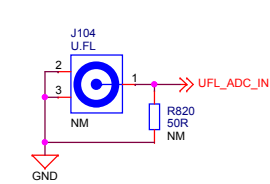

DAC Loopback Analog Switch

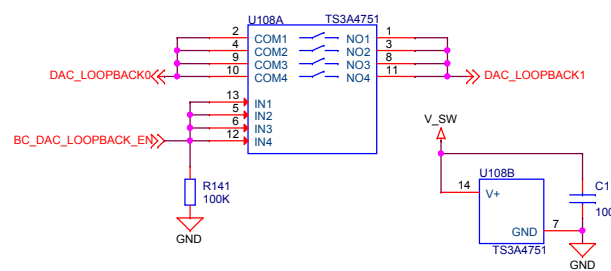

Memory LCD-TFT Display & Multiplexer

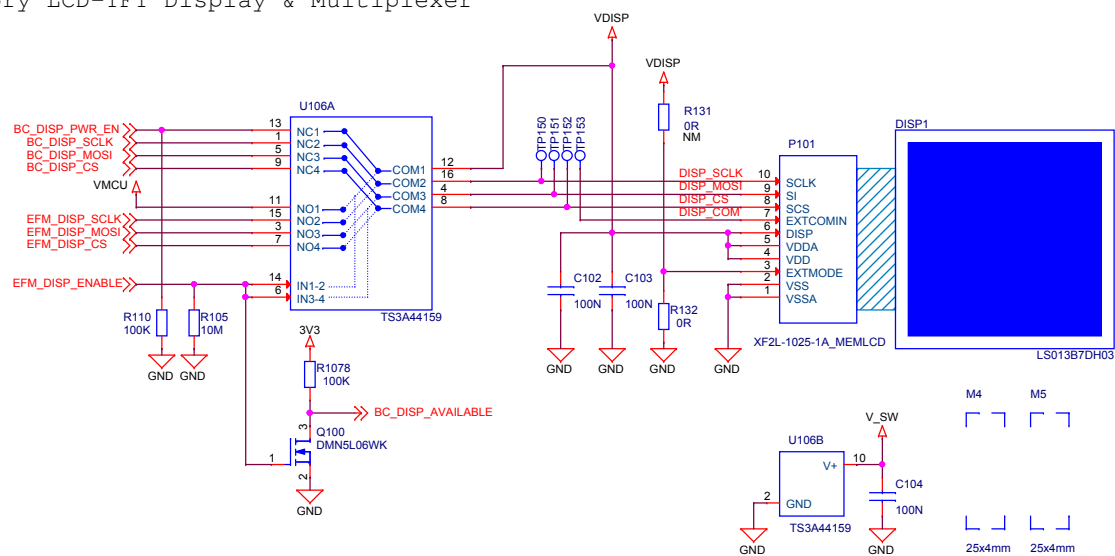

User pushbuttons

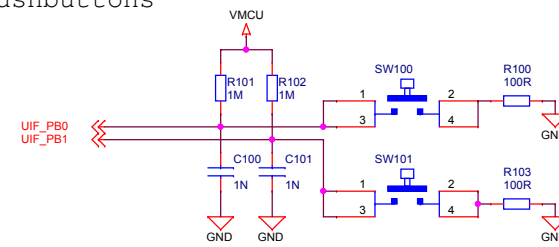

RESET Pushbutton

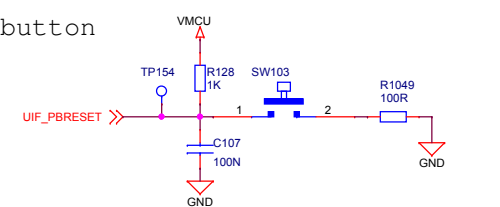

The EFM8 always controls ownership of the display using the EFM_DISP_ENABLE signal.

EFM_DISP_ENABLE	DISP_CTRL	VDISP
0	BC	BC_DISP_PWR_EN
1	EFM	VMCU

STK

		Schematic Title	
		EFM8LB1 Laser Bee Starter Kit	
Designed: MRW Approved: JNO		Page Title	
		User Interfaces	
Size: A3	BOM Doc No:	Document number	Revision
Design Created Date: Wednesday, December 03, 2008		BRD5300A	A03
	Sheet Created Date: Wednesday, August 28, 2013	Sheet Modified Date: Monday, August 01, 2016	Sheet 2 of 10

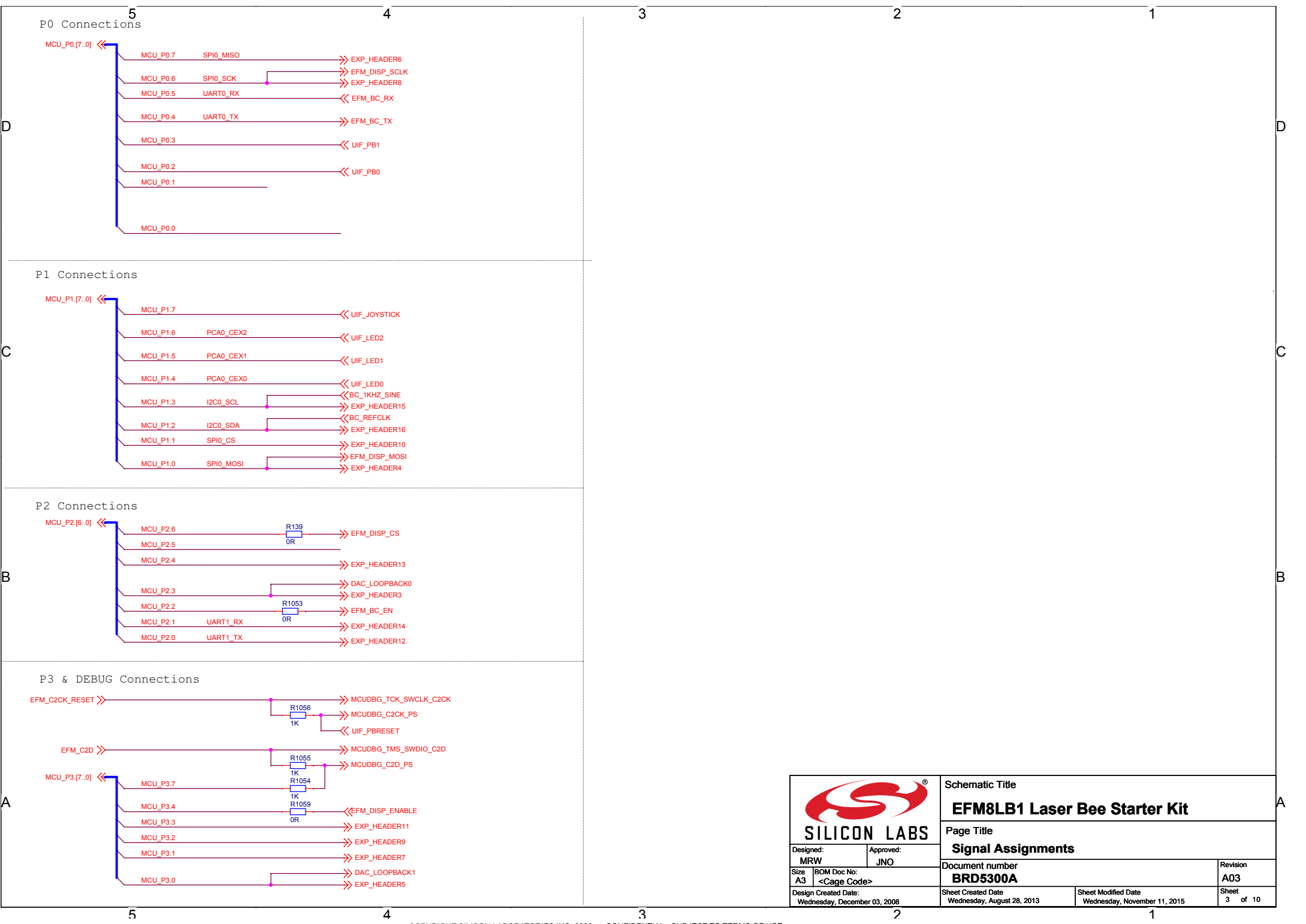

P0 Connections

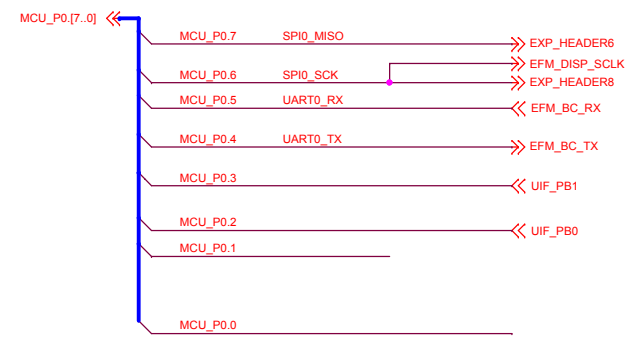

P1 Connections

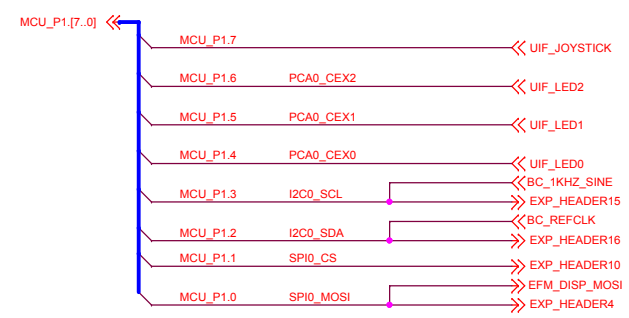

P2 Connections

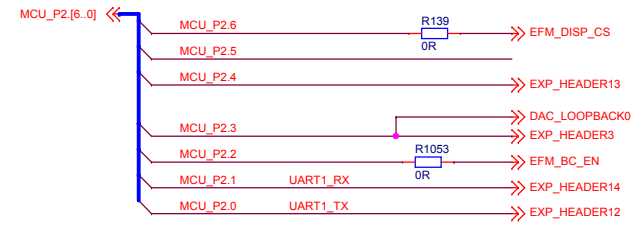

P3 & DEBUG Connections

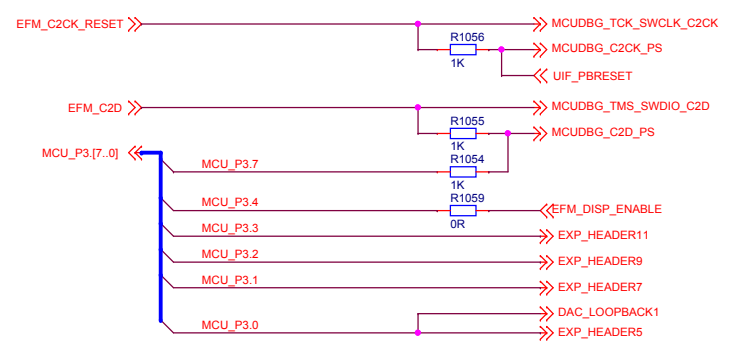

		Schematic Title	
		EFM8LB1 Laser Bee Starter Kit	
Designed: MRW Approved: JNO		Page Title	
		Signal Assignments	
Size: A3	BOM Doc No: <Cage Code>	Document number	Revision
Design Created Date: Wednesday, December 03, 2008	Sheet Created Date: Wednesday, August 28, 2013	BRD5300A	A03
	Sheet Modified Date: Wednesday, November 11, 2015		Sheet 3 of 10

Power Switch

SWITCH POS	MODE DESCRIPTION
AEM	AEM Enabled, VMCU sourced from external 3.3V LDO powered by BC USB 5V supply
BAT	AEM Disabled, VMCU sourced from external coin-cell battery or external power supply

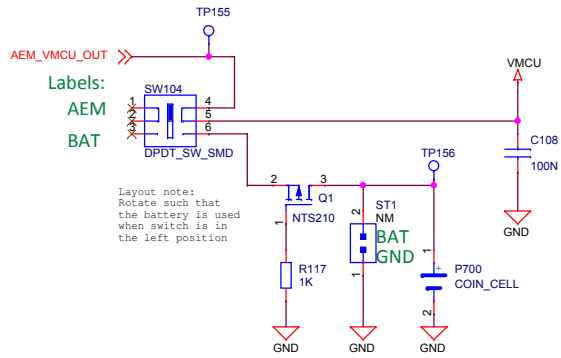

C2 Debug Header

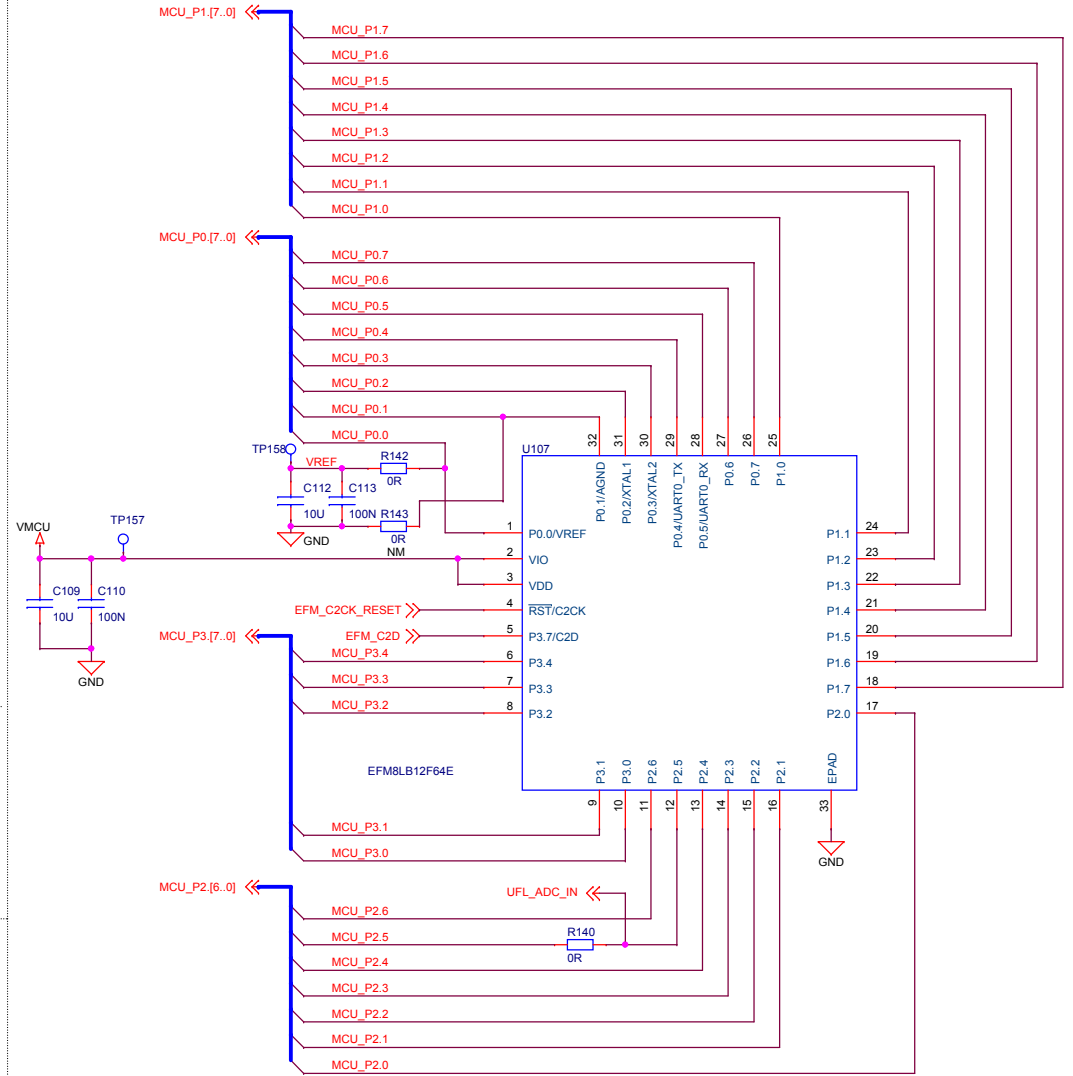

 SILICON LABS		Schematic Title	
		EFM8LB1 Laser Bee Starter Kit	
Designed: MRW Approved: JNO Size: A3 BOM Doc No: <Cage Code>		Page Title	
		EFM8 I/O & Power	
Design Created Date: Wednesday, December 03, 2008		Document number	Revision
Wednesday, December 03, 2008		BRD5300A	A03
Sheet Created Date: Wednesday, August 28, 2013		Sheet Modified Date: Friday, December 04, 2015	Sheet 4 of 10

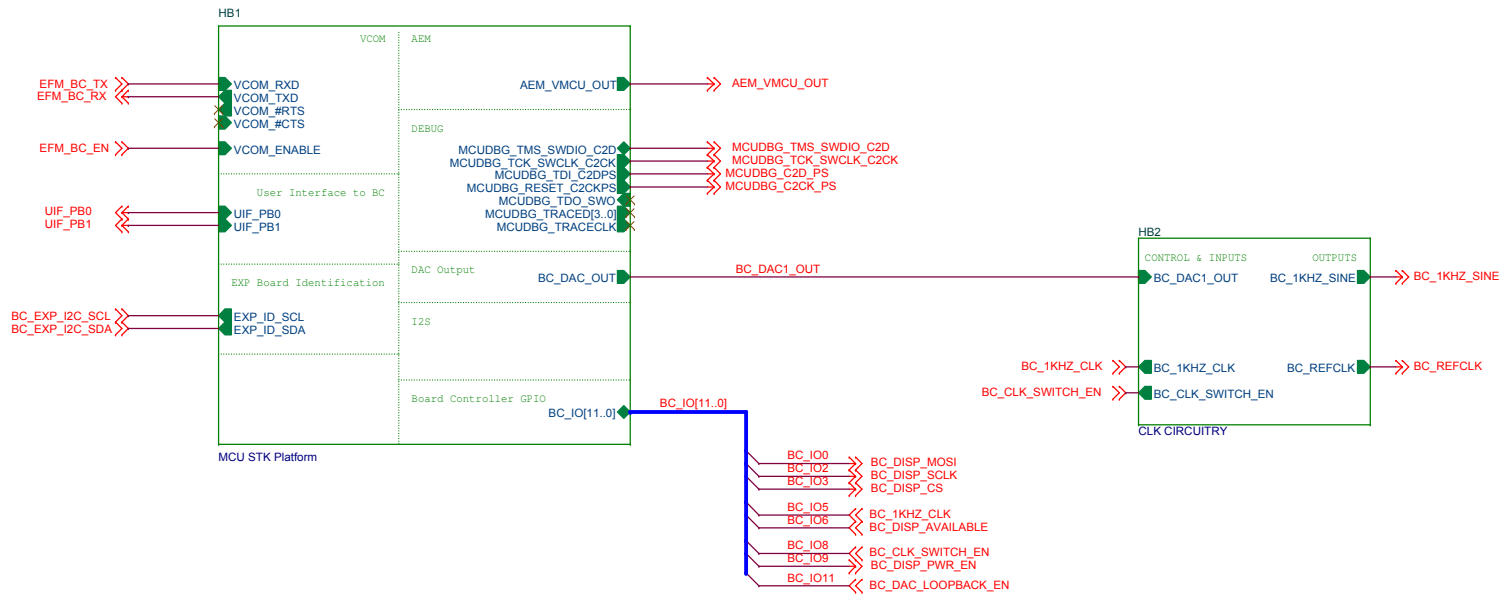

 SILICON LABS		Schematic Title	
		EFM8LB1 Laser Bee Starter Kit	
Designed: MRW Approved: JNO		Page Title	
		STK Common Platform	
Size: A3	BOM Doc No: <Cage Code>	Document number	Revision
Design Created Date: Wednesday, December 03, 2008	Sheet Created Date: Thursday, May 15, 2014	BRD5300A	A03
	Sheet Modified Date: Wednesday, November 11, 2015		Sheet 5 of 10

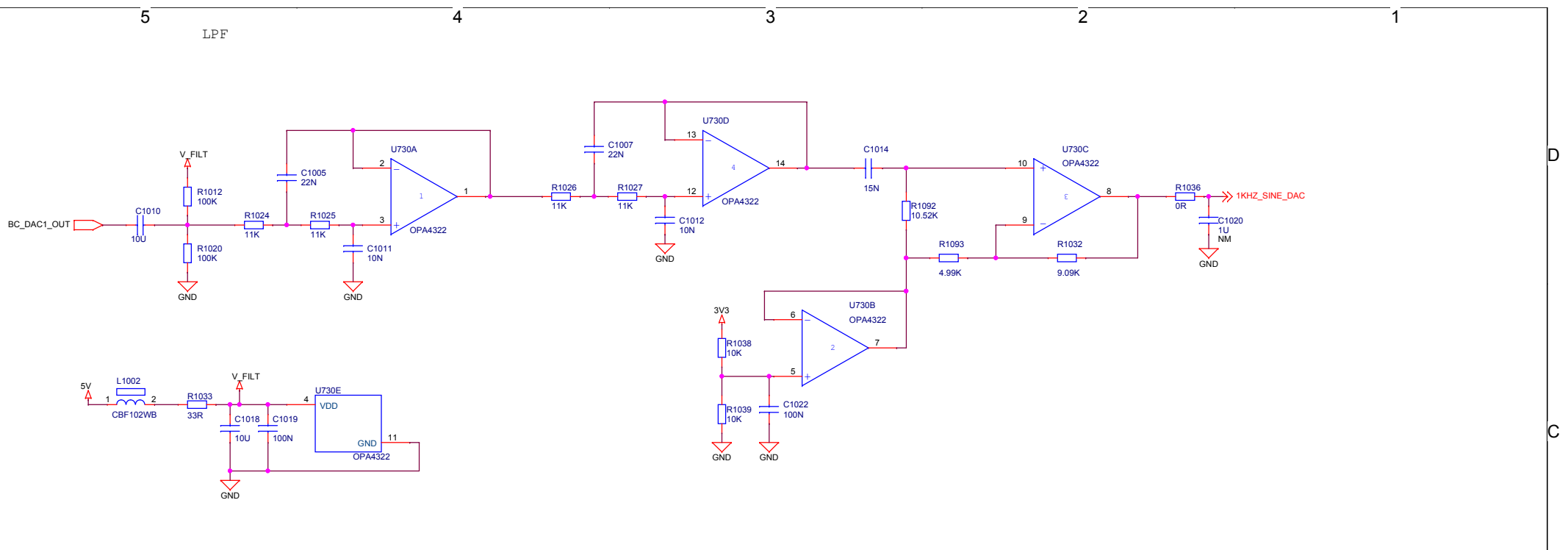

Analog Switch

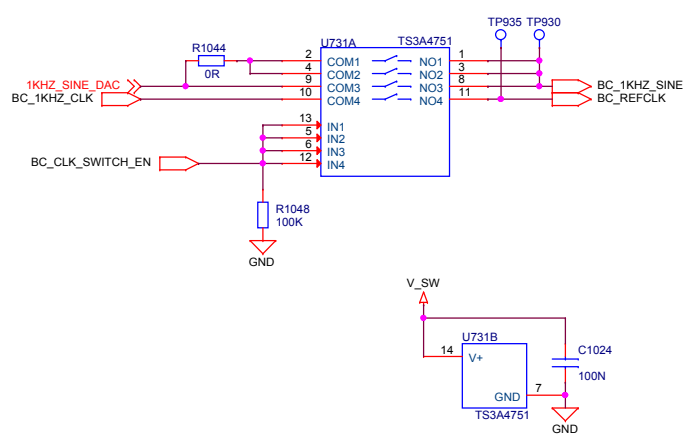

 SILICON LABS		Schematic Title	
		EFM8LB1 Laser Bee Starter Kit	
Designed: MRW Approved: JNO Size: A3 BOM Doc No: <Cage Code> Design Created Date: Wednesday, December 03, 2008		Page Title	
		1 kHz Signal Generator	
Document number BRD5300A		Revision	
		A03	
Sheet Created Date Monday, June 16, 2014		Sheet Modified Date Monday, August 17, 2015	
Sheet 6 of 10			

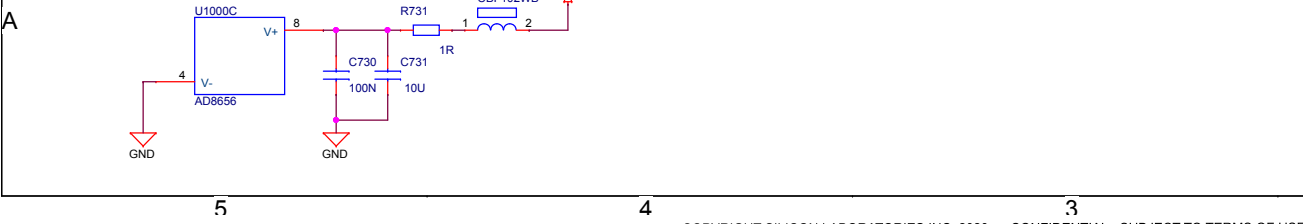
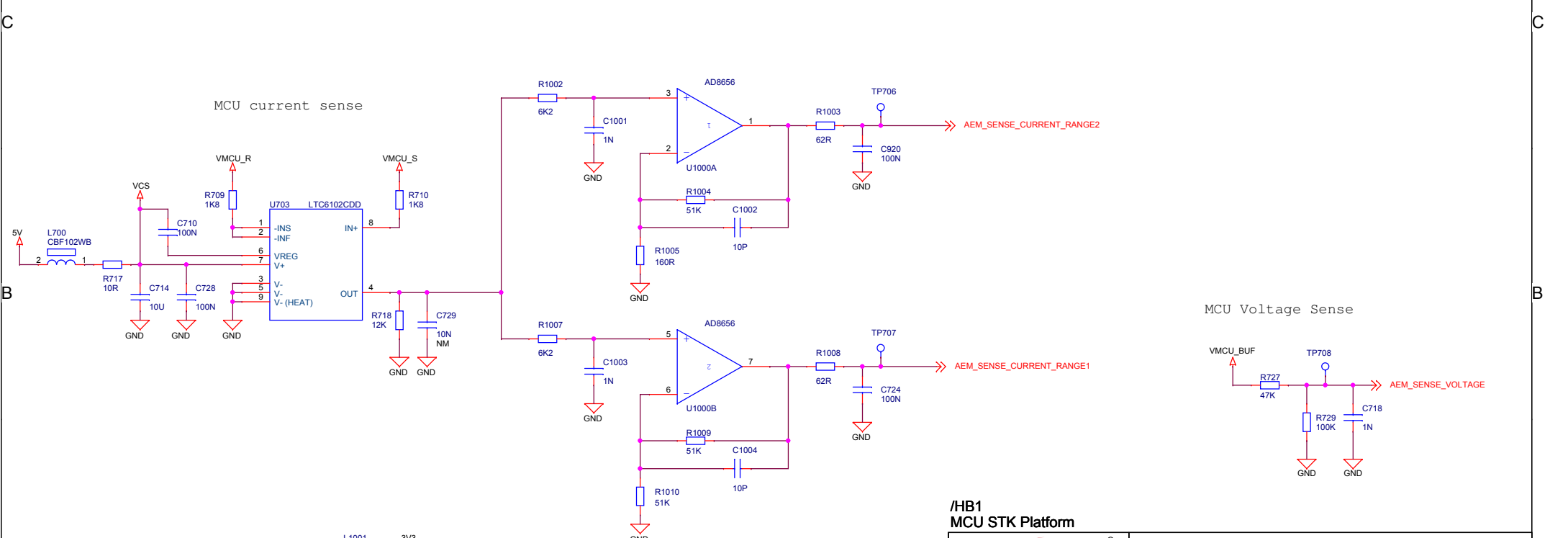
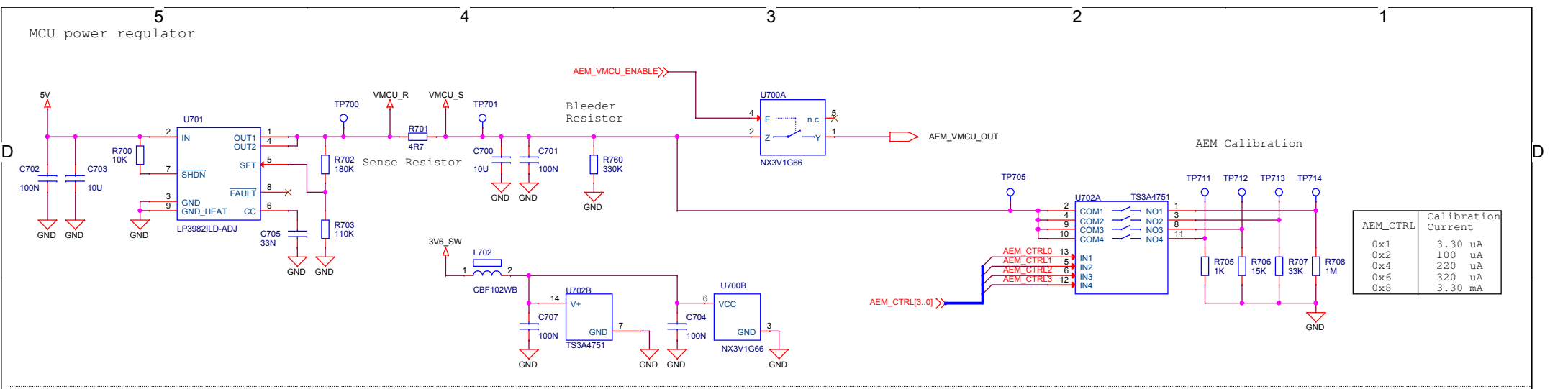

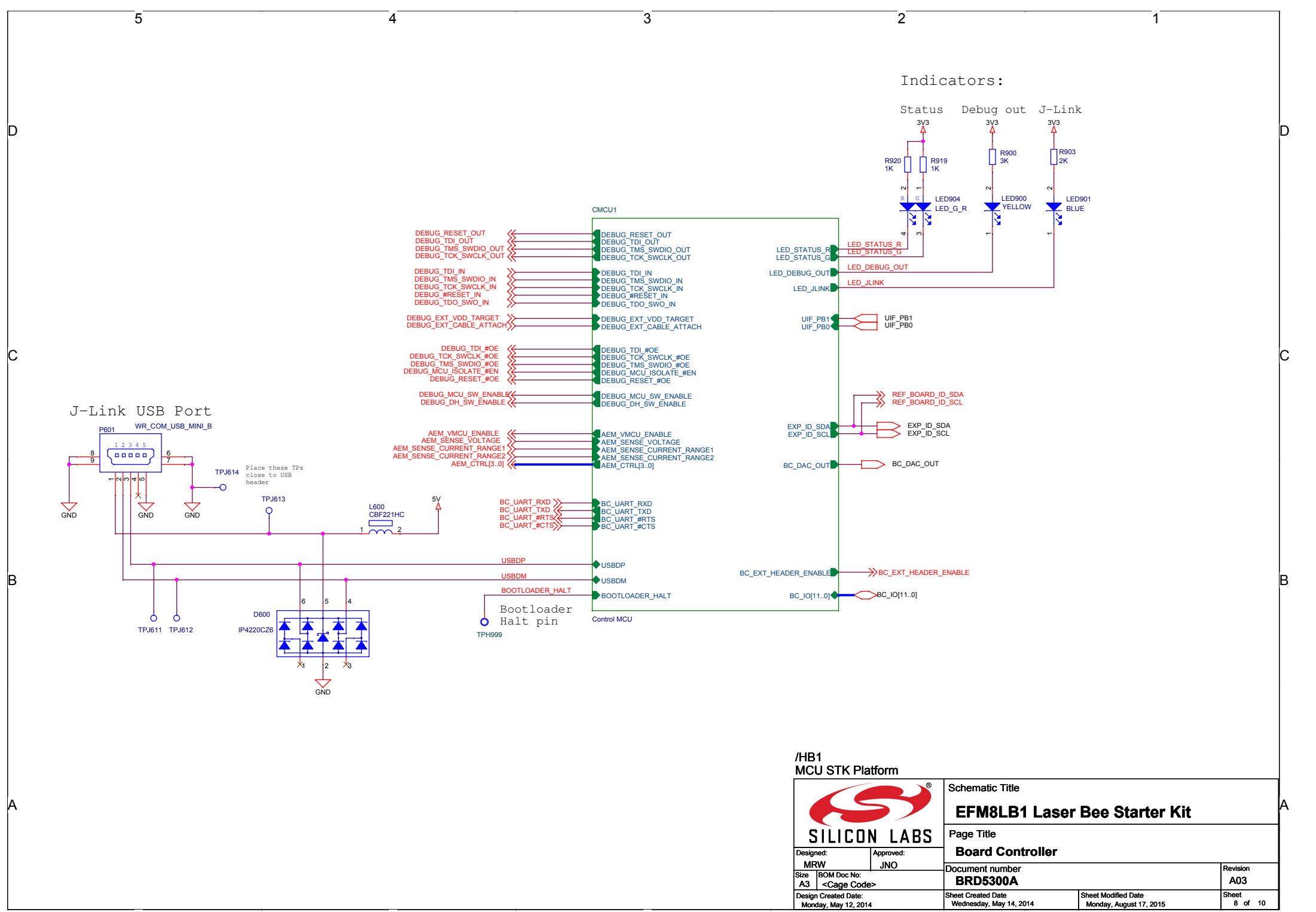

/HB1
MCU STK Platform

Schematic Title		EFM8LB1 Laser Bee Starter Kit	
Page Title		Advanced Energy Monitor	
Designed: MRW	Approved: JNO	Document number	Revision
Size A3	BOM Doc No: <Cage Code>	BRD5300A	A03
Design Created Date: Monday, May 12, 2014	Sheet Created Date Tuesday, May 13, 2014	Sheet Modified Date Monday, August 17, 2015	Sheet 7 of 10

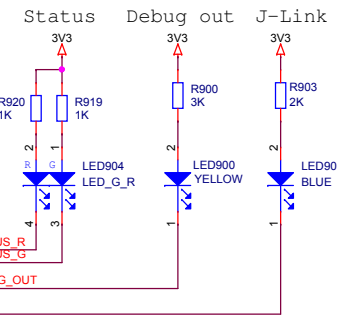

Indicators:



		Schematic Title		
		EFM8LB1 Laser Bee Starter Kit		
Designed: MRW Approved: JNO		Page Title		
		Board Controller		
Size: A3	BOM Doc No: <Cage Code>	Document number		Revision
Design Created Date: Monday, May 12, 2014		BRD5300A		A03
		Sheet Created Date: Wednesday, May 14, 2014	Sheet Modified Date: Monday, August 17, 2015	Sheet 8 of 10

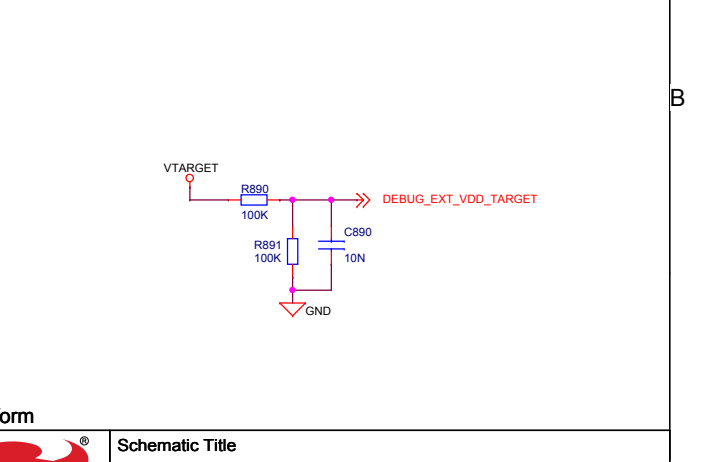
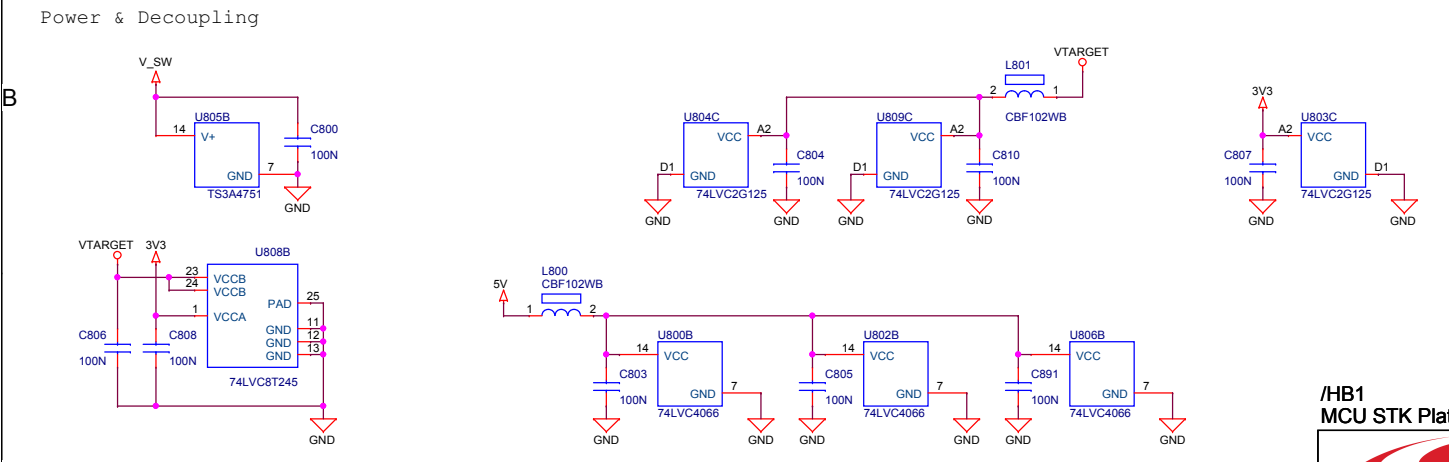
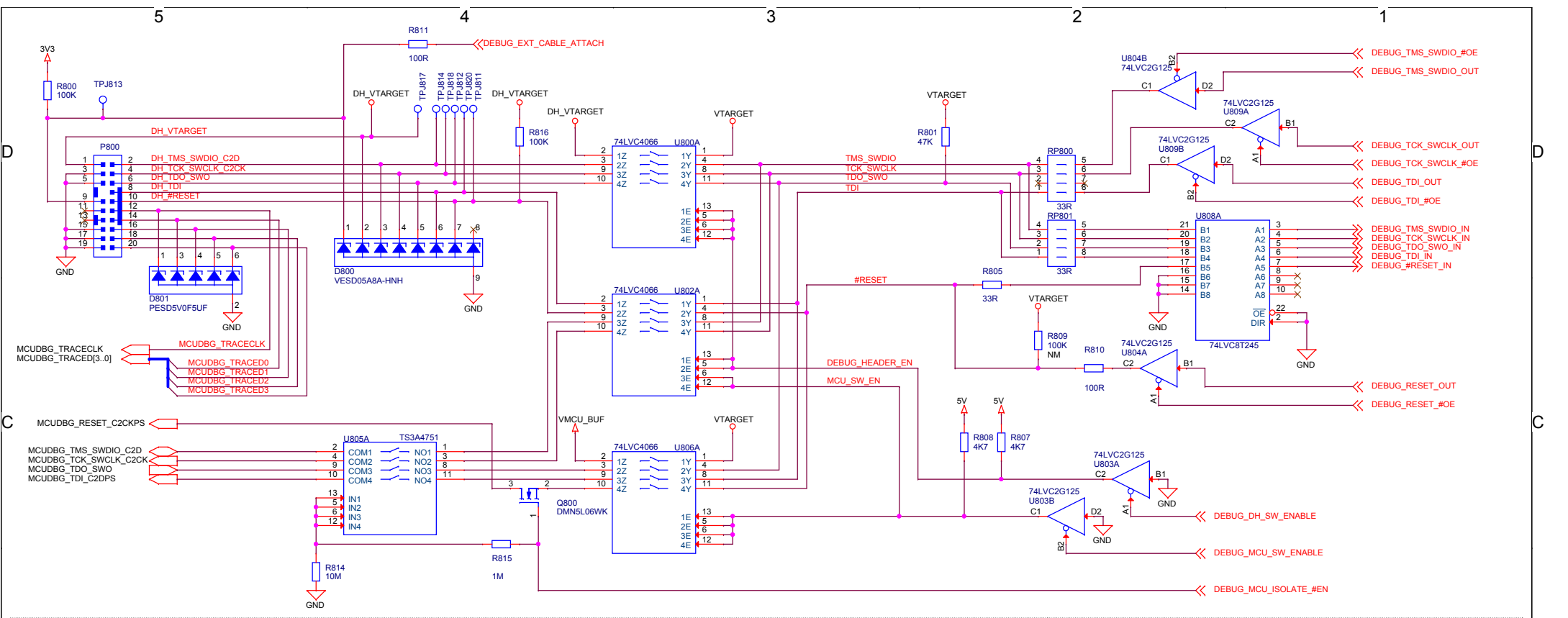

Mode	DEBUG_MCU_SW_ENABLE	DEBUG_DH_SW_ENABLE	DEBUG_BUF_#OE	ISOLATE_#EN	DH_VTARGET	VTARGET
Debug Out	0	1	0	0	External voltage	External voltage
MCU Debug	1	0	0	1	Disconnected	VMCU
Debug In	1	1	1	1	VMCU	VMCU
Debug Off	1	1	1	0	-	-

**/HB1
MCU STK Platform**

Schematic Title
EFM8LB1 Laser Bee Starter Kit

Page Title
Debug Interface

Designed: MRW | Approved: JNO

Size: A3 | BOM Doc No: <Cage Code>

Design Created Date: Monday, May 12, 2014

Document number
BRD5300A

Revision
A03

Sheet Created Date: Monday, May 12, 2014 | Sheet Modified Date: Monday, August 17, 2015 | Sheet 9 of 10

Virtual COM Port Interface

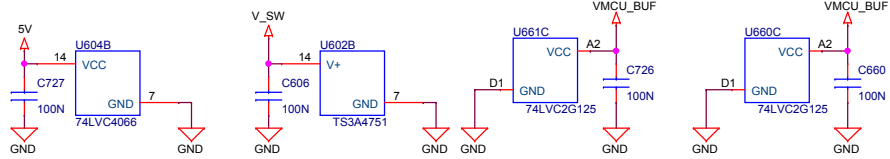
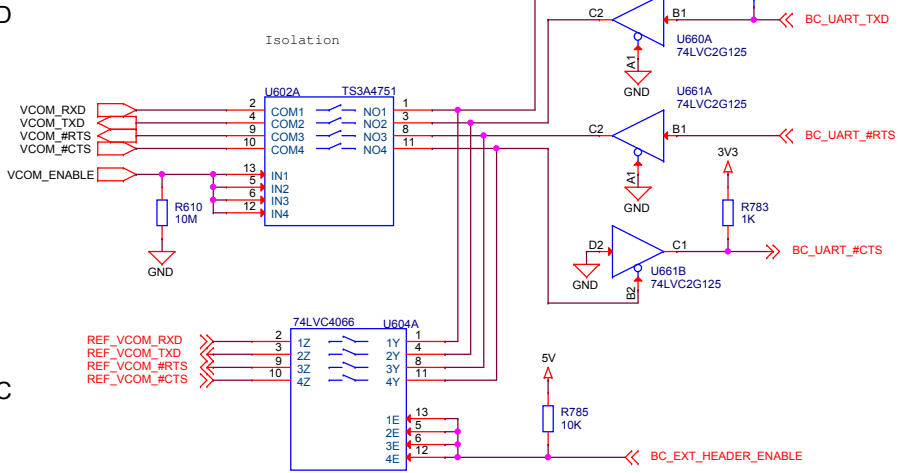

Connector for external reference designs boards

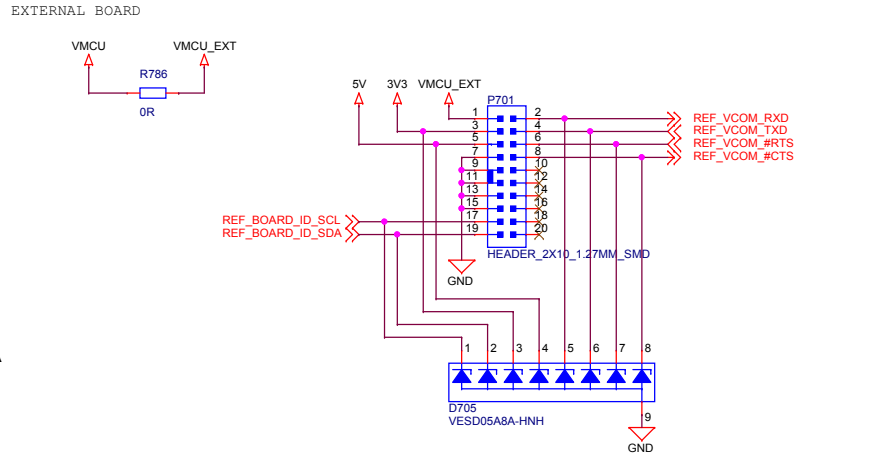

3V3 Regulator

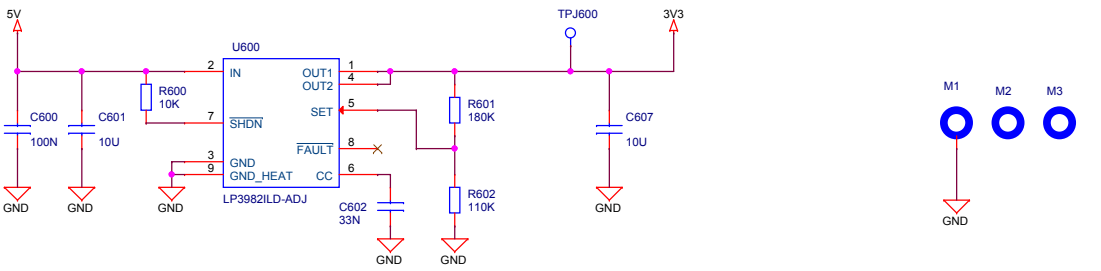

VMCU Voltage Mirror

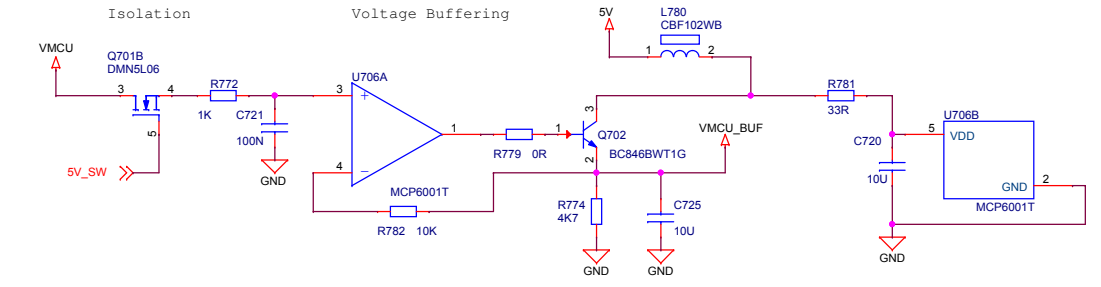

Power Supply for Analog Switches

The USB VBUS voltage is used to bias these transistors, turning the P-Channel MOSFETs (Q700) off, and the N-Channel MOSFETs (Q701) on.

J-Link USB Cable	PMOS State	NMOS State	V_SW	VMCU_SENSE
Connected	Off	ON	3.6V	VMCU
Disconnected	ON	OFF	VMCU	Isolated

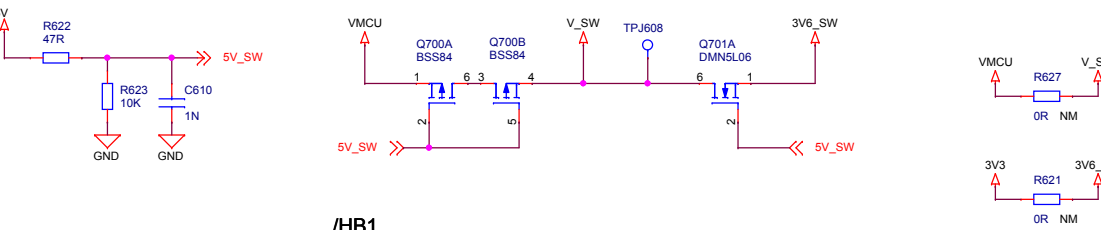
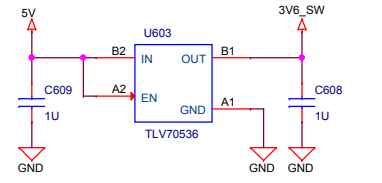

/HB1
MCU STK Platform

		Schematic Title	
		EFM8LB1 Laser Bee Starter Kit	
Designed: MRW Approved: JNO		Page Title	
		Power & Misc	
Size: A3	BOM Doc No: <Cage Code>	Document number	Revision
Design Created Date: Monday, May 12, 2014		BRD5300A	A03
Sheet Created Date: Monday, May 12, 2014	Sheet Modified Date: Monday, August 17, 2015	Sheet 10 of 10	