

# UG596: MGM260P 10 dBm Module Radio Board User's Guide

A Wireless Pro Kit with the BRD4350A Radio Board is an excellent starting point to get familiar with the MGM260P Wireless Gecko PCB Module. It also provides all necessary tools for developing a Silicon Labs wireless application.

BRD4350A is a plug-in board for the Wireless Pro Kit Mainboard (BRD4002A) and the Wireless Starter Kit Mainboard (BRD4001A). It contains the MGM260P Wireless Gecko PCB Module.

The mainboards contain an on-board J-Link debugger with a Packet Trace Interface and a Virtual COM port, enabling application development and debugging of the attached radio board as well as external hardware. The mainboards also contain sensors and peripherals for easy demonstration of some of the MGM260P's many capabilities.

This document describes how to use the BRD4350A Radio Board together with a Wireless Pro Kit Mainboard or a Wireless Starter Kit Mainboard.

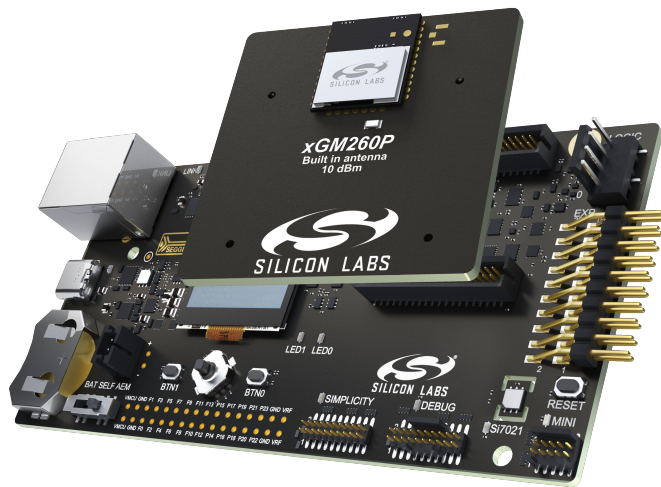

## BRD4350A RADIO BOARD FEATURES

- MGM260P Wireless Gecko Module with built-in PCB Antenna, 3200 kB Flash, and 512 kB RAM (MGM260PD22VNA1)

## MAINBOARD FEATURES

- Advanced Energy Monitor
- Packet Trace Interface
- Logic analyzer (BRD4002A only)
- Virtual COM port
- SEGGER J-Link on-board debugger
- External device debugging
- Ethernet and USB connectivity
- Silicon Labs Si7021 relative humidity and temperature sensor
- Low power 128x128 pixel Memory LCD-TFT
- User LEDs / pushbuttons
- 20-pin 2.54 mm EXP header
- Breakout pads for Module I/O
- CR2032 coin cell battery support

## SOFTWARE SUPPORT

- Simplicity Studio
- Energy Profiler
- Network Analyzer

## ORDERING INFORMATION

- MGM260P-RB4350A

# Table of Contents

<b>1. Introduction . . . . .</b>	<b>4</b>
1.1 Radio Boards . . . . .	4
1.2 Mainboards . . . . .	4
1.3 Ordering Information . . . . .	5
1.4 Getting Started . . . . .	5
<b>2. Hardware Overview . . . . .</b>	<b>6</b>
2.1 Hardware Layout . . . . .	6
2.2 Block Diagram . . . . .	7
<b>3. Connectors . . . . .</b>	<b>8</b>
3.1 J-Link USB Connector . . . . .	8
3.2 Ethernet Connector . . . . .	8
3.3 Breakout Pads . . . . .	9
3.4 EXP Header . . . . .	.10
3.4.1 EXP Header Pinout . . . . .	.11
3.5 Logic Analyzer Connector . . . . .	.12
3.6 Debug Connector . . . . .	.13
3.7 Simplicity Connector . . . . .	.14
3.8 Mini Simplicity Connector . . . . .	.15
3.9 Debug Adapter . . . . .	.16
<b>4. Power Supply and Reset . . . . .</b>	<b>17</b>
4.1 Radio Board Power Selection . . . . .	.17
4.2 Kit Power . . . . .	.18
4.2.1 Board Controller Power . . . . .	.18
4.2.2 AEM Power . . . . .	.18
4.3 Target Reset. . . . .	.18
<b>5. Peripherals . . . . .</b>	<b>19</b>
5.1 Push Buttons and LEDs . . . . .	.19
5.2 Joystick . . . . .	.19
5.3 Memory LCD-TFT Display . . . . .	.20
5.4 Si7021 Relative Humidity and Temperature Sensor . . . . .	.21
5.5 Virtual COM Port . . . . .	.22
5.5.1 Host Interfaces . . . . .	.23
5.5.2 Serial Configuration . . . . .	.23
5.5.3 Hardware Handshake . . . . .	.24
<b>6. Board Controller . . . . .</b>	<b>25</b>
6.1 Introduction . . . . .	.25

6.2 Admin Console . . . . .	.25
6.2.1 Connecting . . . . .	.25
6.2.2 Built-in Help . . . . .	.26
6.2.3 Command Examples . . . . .	.26
6.3 Virtual UART . . . . .	.26
6.3.1 Target-to-Host. . . . .	.26
6.3.2 Host-to-Target. . . . .	.27
6.3.3 Limitations . . . . .	.27
6.3.4 Troubleshooting . . . . .	.27
<b>7. Advanced Energy Monitor . . . . .</b>	<b>.28</b>
7.1 Introduction . . . . .	.28
7.2 Code Correlation . . . . .	.28
7.3 AEM Circuit . . . . .	.28
7.3.1 AEM Details . . . . .	.29
<b>8. On-Board Debugger . . . . .</b>	<b>30</b>
8.1 Host Interfaces . . . . .	.30
8.1.1 USB Interface . . . . .	.30
8.1.2 Ethernet Interface . . . . .	.30
8.1.3 Serial Number Identification . . . . .	.30
8.2 Debug Modes . . . . .	.31
8.3 Debugging During Battery Operation . . . . .	.32
<b>9. Kit Configuration and Upgrades . . . . .</b>	<b>33</b>
9.1 Firmware Upgrades . . . . .	.33
<b>10. Schematics, Assembly Drawings, and BOM . . . . .</b>	<b>34</b>
<b>11. Kit Revision History . . . . .</b>	<b>35</b>
11.1 MGM260P-RB4350A Revision History . . . . .	.35
<b>12. Document Revision History . . . . .</b>	<b>.36</b>

## 1. Introduction

The MGM260P Wireless Gecko Module is featured on a radio board that plugs directly into a Wireless Starter Kit (Wireless STK) Mainboard or a Wireless Pro Kit Mainboard. The mainboards feature several tools for easy evaluation and development of wireless applications. An on-board J-Link debugger enables programming and debugging on the target device over USB or Ethernet. The Advanced Energy Monitor (AEM) offers real-time current and voltage monitoring. A virtual COM port interface (VCOM) provides an easy-to-use serial port connection over USB or Ethernet. The Packet Trace Interface (PTI) offers invaluable debug information about transmitted and received packets in wireless links. All debug functionality, including AEM, VCOM, and PTI, can also be used towards external target hardware instead of the attached radio board.

To further enhance its usability, the mainboard contains sensors and peripherals that demonstrate some of the many capabilities of the MGM260P. The mainboard also has a 20-pin EXP header which can be used for connecting EXP boards to the kit or for easy connection to I/Os on the radio board target IC.

### 1.1 Radio Boards

A Wireless Pro Kit consists of one or more mainboards and radio boards that plug into the mainboard. Different radio boards are available, each featuring different Silicon Labs devices with different operating frequency bands. Because the mainboards are designed to work with different radio boards, the actual pin mapping from a device pin to a mainboard feature is done on the radio board. This means that each radio board has its own pin mapping to the Wireless Pro Kit features, such as buttons, LEDs, the display, the EXP header, and the breakout pads. Because this pin mapping is different for every radio board, it is important to consult the correct document, which shows the kit features in context of the radio board plugged in.

### 1.2 Mainboards

The MGM260P 10 dBm Module Radio Board (BRD4350A) can be used with either a Wireless Starter Kit Mainboard (BRD4001A) or a Wireless Pro Kit Mainboard (BRD4002A). The Wireless Pro Kit Mainboard is the successor to the Wireless Starter Kit Mainboard, which comes with some improvements and added features including increased AEM measurement range and sample rate, variable VMCU voltage, joystick, a logic analyzer, and a Mini Simplicity Connector. Kit features, such as the Si7021 sensor and the EXP header, are available on the same MGM260P pins regardless of the mainboard being used, but the pinout to the breakout pads differs. The combination of the MGM260P 10 dBm Module Radio Board with either one of these mainboards is hereby referred to as a Wireless Pro Kit as the figure below illustrates.

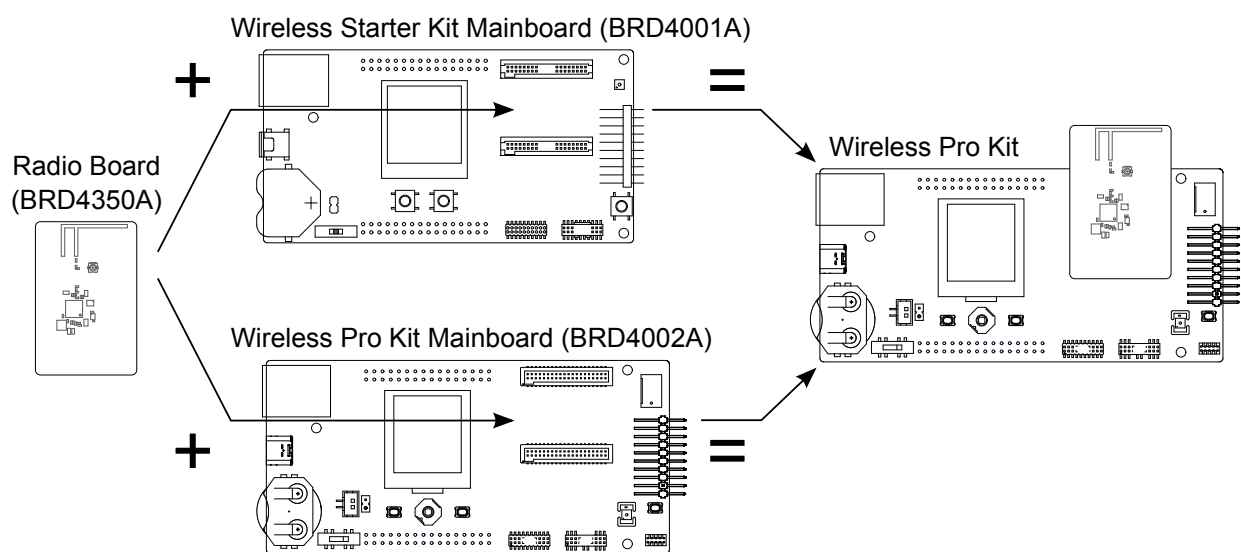

**Figure 1.1. Wireless Pro Kit Combinations**

**Note:** This document explains how to use the Wireless Pro Kit when the MGM260P 10 dBm Module Radio Board (BRD4350A) is combined with either a Wireless Starter Kit Mainboard (BRD4001A) or a Wireless Pro Kit Mainboard (BRD4002A). Since some of the functionality of the kit depends on the type of mainboard used, it is important to consult the right information in the user guide whenever there are discrepancies.

### 1.3 Ordering Information

BRD4350A can be obtained as a separate radio board, MGM260P-RB4350A.

**Table 1.1. Ordering Information**

Part Number	Description	Contents
MGM260P-RB4350A	MGM260P 10 dBm Module Radio Board	1x BRD4350A MGM260P 10 dBm Module Radio Board

### 1.4 Getting Started

Detailed instructions for how to get started can be found on the Silicon Labs web pages: <http://www.silabs.com/dev-tools>.

## 2. Hardware Overview

### 2.1 Hardware Layout

The layout of the MGM260P 10 dBm Module Wireless Pro Kit when the radio board is combined with a Wireless Pro Kit Mainboard (BRD4002A) or a Wireless STK Mainboard (BRD4001A) is shown below.

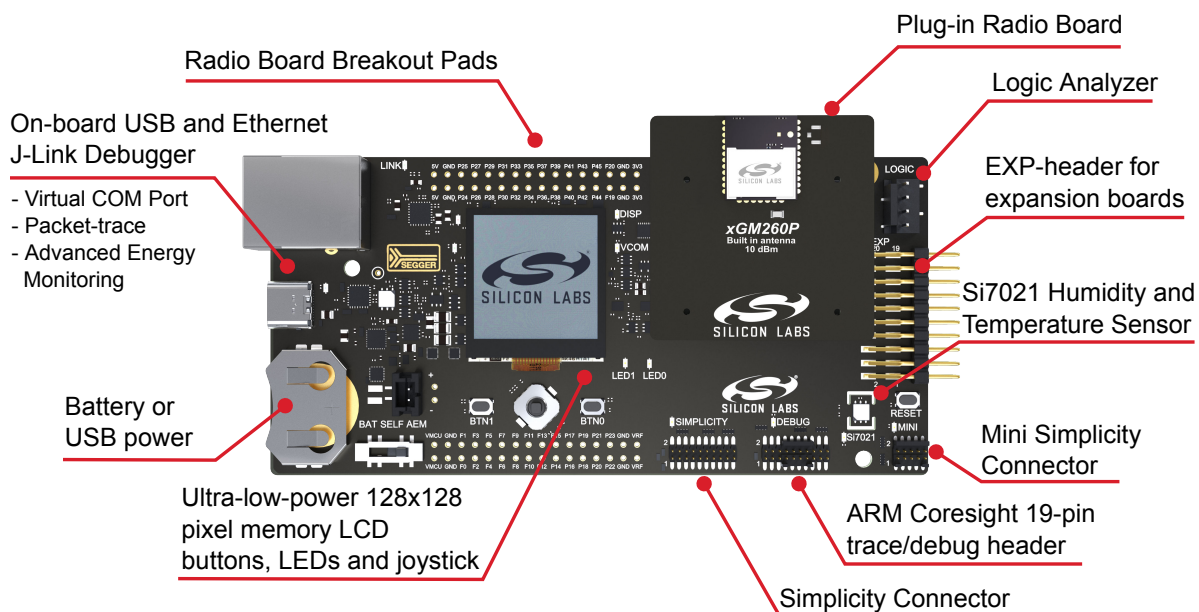

Figure 2.1. Hardware Layout With A Wireless Pro Kit Mainboard (BRD4002A)

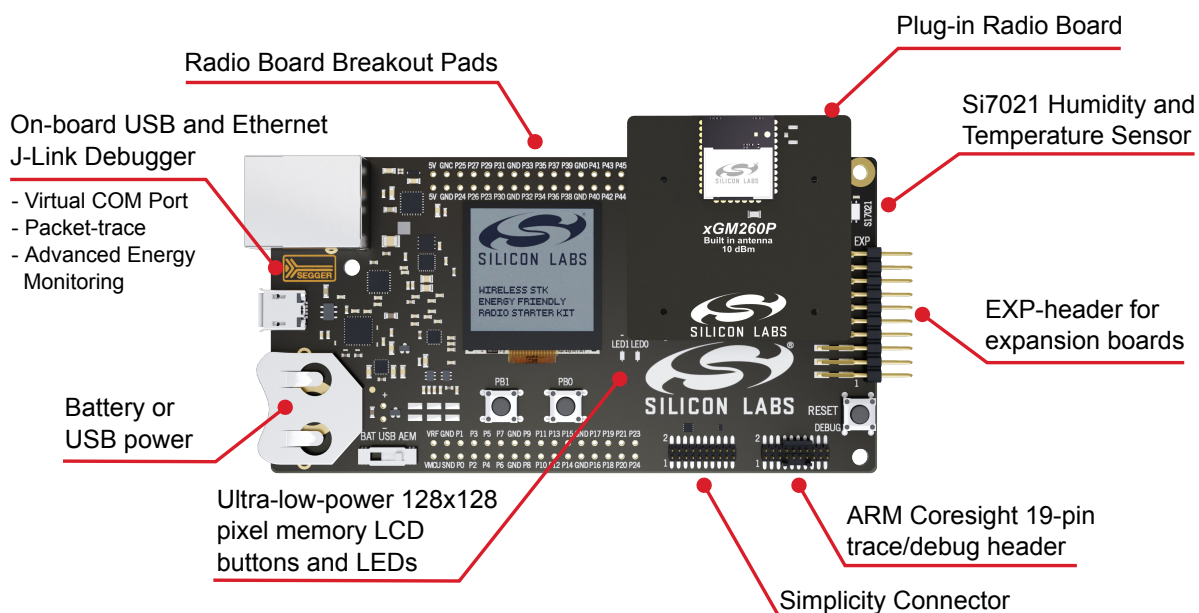
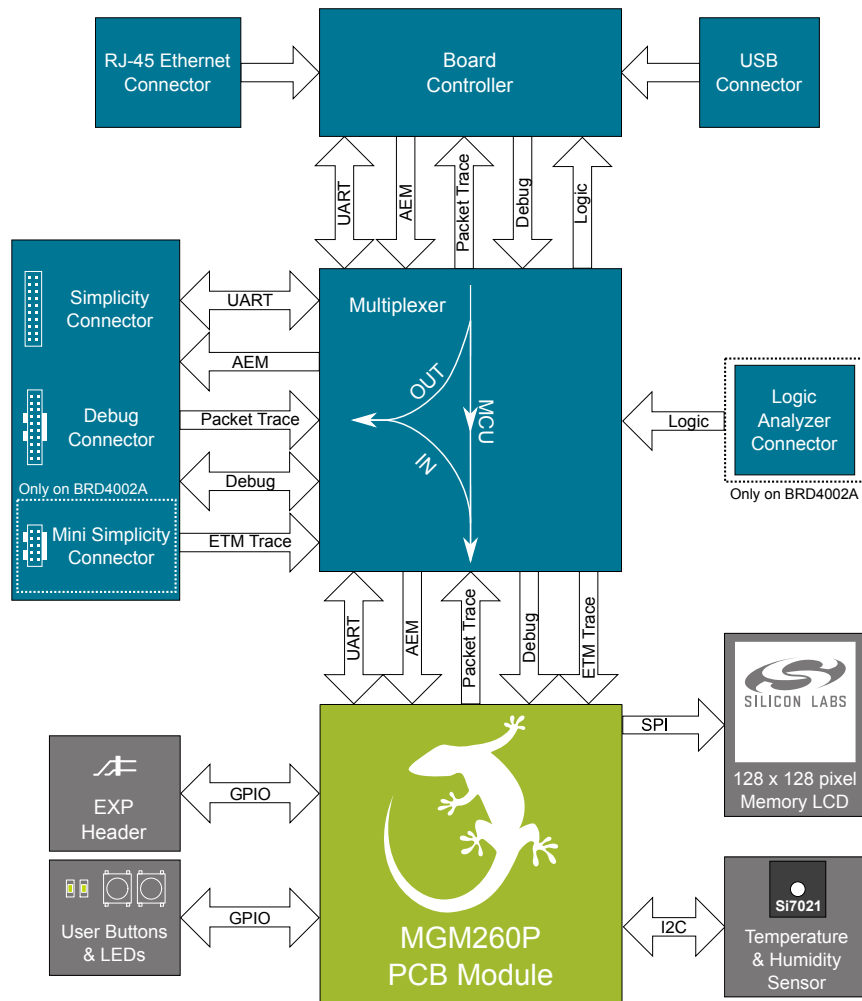

Figure 2.2. Hardware Layout With A Wireless STK Mainboard (BRD4001A)

## 2.2 Block Diagram

A block diagram of the MGM260P 10 dBm Module Wireless Pro Kit is shown in the figure below.



**Figure 2.3. Kit Block Diagram**

### 3. Connectors

This chapter gives you an overview of the mainboard connectivity. The placement of the connectors on the Wireless Pro Kit Mainboard (BRD4002A) and the Wireless STK Mainboard (BRD4001A) is shown below.

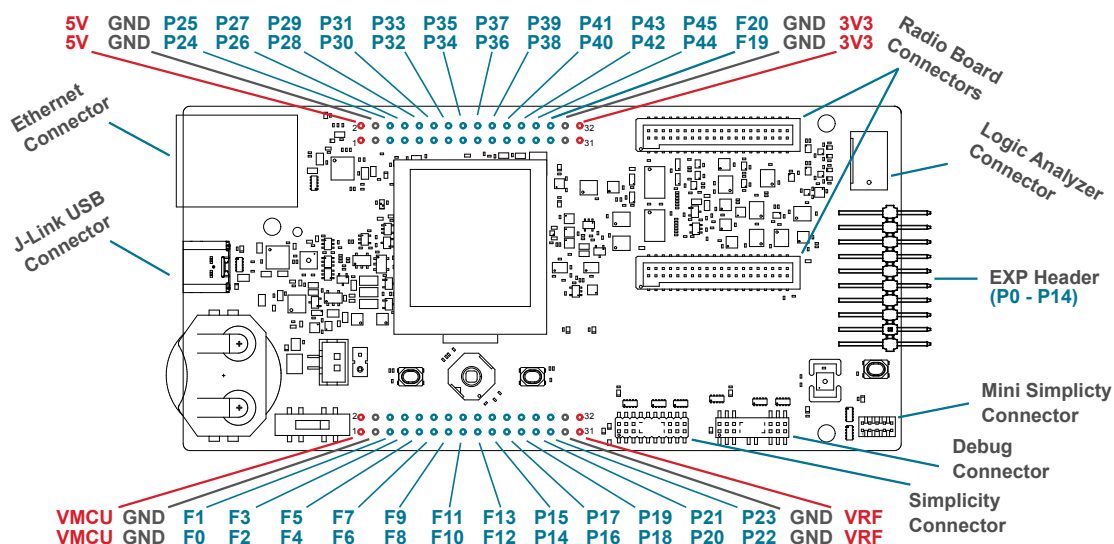

Figure 3.1. Wireless Pro Kit Mainboard (BRD4002A) Connector Layout

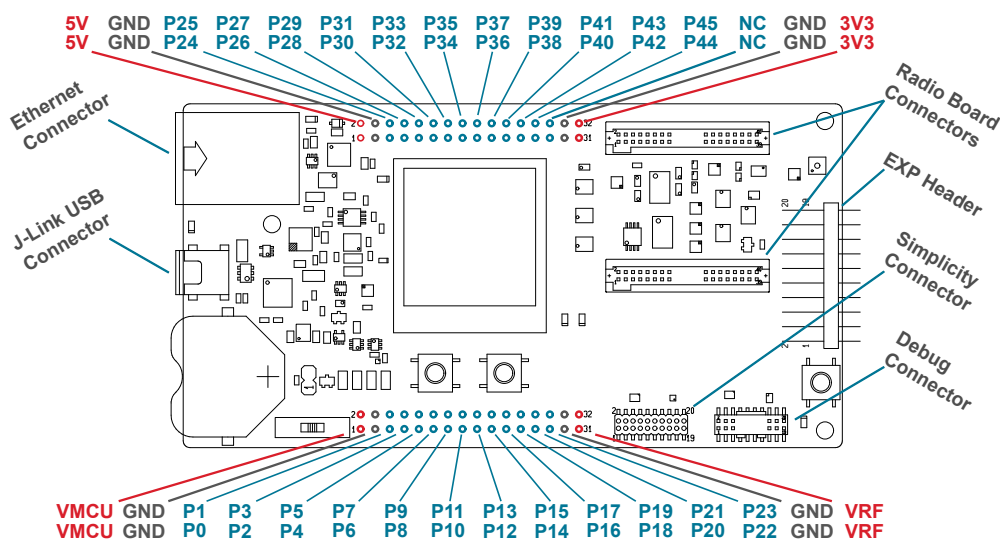

Figure 3.2. Wireless STK Mainboard (BRD4001A) Connector Layout

#### 3.1 J-Link USB Connector

The J-Link USB connector is situated on the left side of the mainboard and provides access to the kit features described in Section 6. [Board Controller](#) through the USB interface. In addition to providing access to development features of the kit, this USB connector is also the main power source for the kit powering both the board controller and the AEM as described in Section 4. [Power Supply and Reset](#).

#### 3.2 Ethernet Connector

The Ethernet connector is situated on the left side of the mainboard and provides access to the kit features described in Section 6. [Board Controller](#) over TCP/IP. The J-Link USB connector must be connected while using this interface to provide power to the Wireless Pro Kit as power is not supplied over the Ethernet connector.



### 3.3 Breakout Pads

Most of the MGM260P pins are routed from the radio board to breakout pads at the top and bottom edges of the mainboard. A 2.54 mm pitch pin header can be soldered on for easy access to the pins. The figures below show how the MGM260P pins map to the pin numbers printed on the breakout pads on the Wireless Pro Kit Mainboard (BRD4002A) and the Wireless STK Mainboard (BRD4001A). To see the available functions on each pin, refer to the data sheet for MGM260PD22VNA1.

**Note:** Pinout to the breakout pads depends on the mainboard being used.

BOTTOM EDGE	
VMCU	o o VMCU
GND	o o GND
DBG_TMS_SWDIO / PA02 / F0	o o F1 / PA01 / DBG_TCK_SWCLK
TRACED0 / DBG_TDO_SWO / PA03 / F2	o o F3 / PA04 / DBG_TDI / TRACECLK
RESET / RESETn / F4	o o F5 / PB04 / VCOM_ENABLE
EXP12 / VCOM_TX / PA05 / F6	o o F7 / PA06 / VCOM_RX / EXP14
VCOM_CTS / PA08 / F8	o o F9 / PA07 / VCOM_RTS
UIF_LED0 / PC07 / F10	o o F11 / PC08 / UIF_LED1
EXP7 / UIF_BUTTON0 / PB00 / F12	o o F13 / PB01 / UIF_BUTTON1 / EXP9
TRACECLK / DBG_TDI / PA04 / P14	o o P15 / PB04 / VCOM_ENABLE
TRACED0 / DBG_TDO_SWO / PA03 / P16	o o P17 / PA07 / VCOM_RTS / TRACED3*
DBG_TMS_SWDIO / PA02 / P18	o o P19 / PA08 / VCOM_CTS
DBG_SWCLK / PA01 / P20	o o P21 / PC07 / UIF_LED0
NC / P22	o o P23 / PC08 / UIF_LED1
GND	o o GND
VRF	o o VRF
TOP EDGE	
5V	o o 5V
GND	o o GND
NC / P24	o o P25 / PC04 / PTI0_DATA
NC / P26	o o P27 / PC05 / PTI0_SYNC
NC / P28	o o P29 / PD03 / DISP_ENABLE
NC / P30	o o P31 / PA00 / DISP_EXTCOMIN
NC / P32	o o P33 / PC06 / DISP_SCS
NC / P34	o o P35 / NC
JOYSTICK / PD04 / P36	o o P37 / PD02 / SENSOR_ENABLE
NC / P38	o o P39 / NC
NC / P40	o o P41 / PA04 / DBG_TDI / TRACECLK
TRACED0 / DBG_TDO_SWO / PA03 / P42	o o P43 / (PA05 / TRACED1)*
(TRACED2 / PA06)* / P44	o o P45 / (PA07 / TRACED3)*
PTI0_SYNC / PC05 / F19	o o F20 / PC04 / PTI0_DATA
GND	o o GND
3V3	o o 3V3

\* Optional connection, not enabled by default

**Figure 3.3. Wireless Pro Kit Mainboard (BRD4002A) Breakout Pad Pin Mapping**

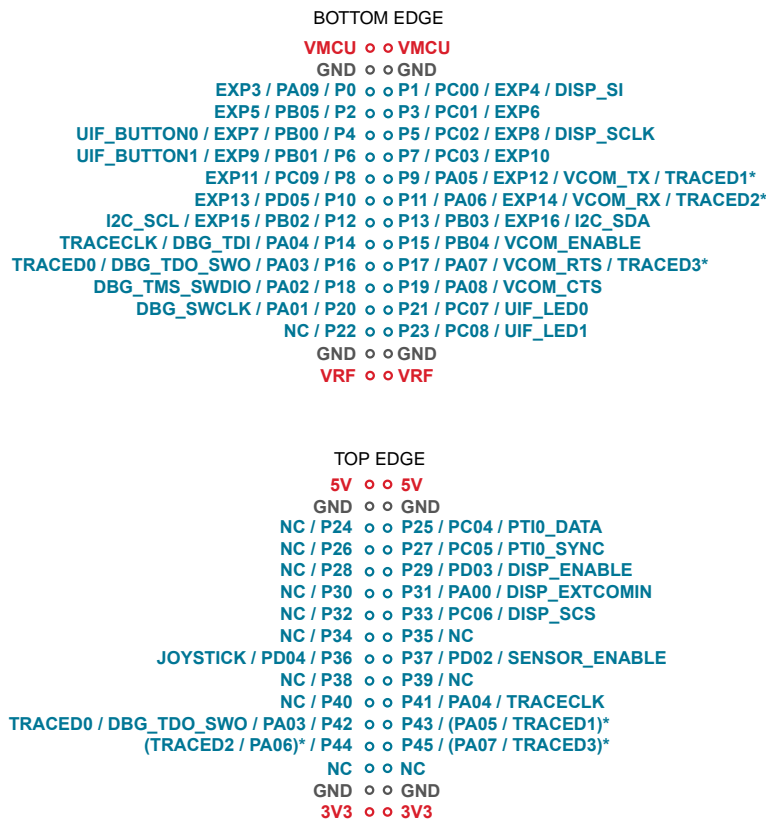

\* Optional connection, not enabled by default

Figure 3.4. Wireless STK Mainboard (BRD4001A) Breakout Pad Pin Mapping

### 3.4 EXP Header

The EXP header is an angled, 20-pin header that allows connection of peripherals or plugin boards to the kit. It is located on the right-hand side of the mainboard and contains several I/O pins that can be used with most of the MGM260P's features. Additionally, the VMCU, 3V3, and 5V power rails are also exposed.

The pin-out is standardized so commonly used peripherals, such as SPI, UART, and I2C, are available on fixed locations. The remaining pins are assigned to general purpose IO. This allows the definition of EXP boards that can be used with most radio boards.

The figure below shows the pin assignment of the EXP header.

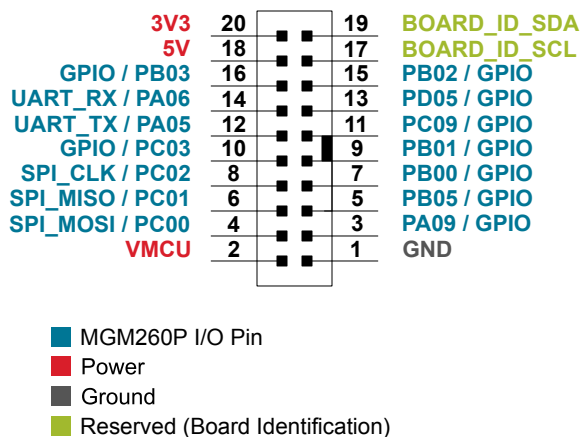

Figure 3.5. EXP Header

### 3.4.1 EXP Header Pinout

The pin-routing on the MGM260P is very flexible, so most peripherals can be routed to any pin. However, many pins are shared between the EXP header and other functions on the mainboard. The table below includes an overview of the mainboard features that share pins with the EXP header.

**Table 3.1. EXP Header Pinout**

Pin	Connection	EXP Header Function	Shared Feature	Peripheral Mapping
20	3V3	Board controller supply		
18	5V	Board USB voltage		
16	PB03	I2C_SDA	SENSOR_SDA	I2C0_SDA
14	PA06	UART_RX	VCOM_RX	USART0_RX
12	PA05	UART_TX	VCOM_TX	USART0_TX
10	PC03	SPI_CS	–	USART1_CS
8	PC02	SPI_SCLK	DISP_SCLK	USART1_CLK
6	PC01	SPI_MISO	–	USART1_RX
4	PC00	SPI_MOSI	DISP_MOSI	USART1_TX
2	VMCU	MGM260P voltage domain, included in AEM measurements.		
19	BOARD_ID_SDA	Connected to board controller for identification of add-on boards.		
17	BOARD_ID_SCL	Connected to board controller for identification of add-on boards.		
15	PB02	I2C_SCL	SENSOR_SCL	I2C0_SCL
13	PD05	GPIO	–	–
11	PC09	GPIO	–	–
9	PB01	GPIO	BUTTON1	–
7	PB00	GPIO	BUTTON0	–
5	PB05	GPIO	–	–
3	PA09	GPIO	–	–
1	GND	Ground		

### 3.5 Logic Analyzer Connector

The Wireless Pro Kit Mainboard includes an on-board, eight-channel logic analyzer. It enables four digital signals to be sampled and displayed in Simplicity Studio, in addition to the state of the on-board user interface LEDs and buttons. The logic analyzer is a good tool for correlating specific events to the AEM energy profile and packet trace data as these are time-synchronized and can be visualized together. The sampling rate of 100 kHz limits its use in decoding digital protocols like I<sup>2</sup>C or SPI.

The logic analyzer connector is situated on the top right side of the Wireless Pro Kit Mainboard. Four signals (channel 0-3) can be connected to the logic analyzer using this connector and the test probes that are obtainable through the "Si-DA001A Pro Kit Mainboard Accessory Kit". The test probes can be connected to the kit itself or on an external board connected to the Wireless Pro Kit Mainboard. Note that in both cases the connected signals must be digital, and the voltages referenced to ground and VMCU on the Wireless Pro Kit Mainboard. The table below gives an overview of the logic analyzer signals.

**Note:** The logic analyzer is only available on the Wireless Pro Kit Mainboard (BRD4002A). Test probes are not included with all Pro Kits. If needed, they can be obtained separately as Si-DA001A Pro Kit Mainboard Accessory Kit.

**Table 3.2. Logic Analyzer Signal Description**

Type	Channel	Description
External signal	0	Connector (ch0)
	1	Connector (ch1)
	2	Connector (ch2)
	3	Connector (ch3)
Internal signal	4	LED0
	5	LED1
	6	BTN0
	7	BTN1

### 3.6 Debug Connector

The debug connector serves multiple purposes based on the "debug mode" setting which can be configured in Simplicity Studio. When the debug mode is set to "Debug IN", the debug connector can be used to connect an external debugger to the MGM260P on the radio board. When set to "Debug OUT", this connector allows the kit to be used as a debugger towards an external target. When set to "Debug MCU" (default), the connector is isolated from both the on-board debugger and the radio board target device.

Because this connector is electronically switched between the different operating modes, it can only be used when the board controller is powered (i.e., J-Link USB cable connected). If debug access to the target device is required when the board controller is unpowered, connect directly to the appropriate breakout pins.

The pinout of the connector follows that of the standard ARM Cortex Debug+ETM 19-pin connector. The pinout is described in detail below. Even though the connector has support for both JTAG and ETM Trace, it does not necessarily mean that the kit or the on-board target device supports these features.

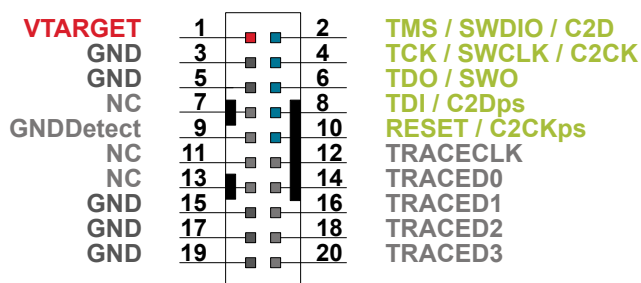

Figure 3.6. Debug Connector

**Note:** The pinout matches the pinout of an ARM Cortex Debug+ETM connector, but these are not fully compatible because pin 7 is physically removed from the Cortex Debug+ETM connector. Some cables have a small plug that prevents them from being used when this pin is present. If this is the case, remove the plug or use a standard 2x10 1.27 mm straight cable instead.

Table 3.3. Debug Connector Pin Descriptions

Pin Number(s)	Function	Description
1	VTARGET	Target reference voltage. Used for shifting logical signal levels between target and debugger.
2	TMS / SWDIO / C2D	JTAG TMS, Serial Wire data I/O, or C2 data
4	TCK / SWCLK / C2CK	JTAG TCK, Serial Wire clock, or C2 clock
6	TDO/SWO	JTAG TDO, or Serial Wire output
8	TDI / C2Dps	JTAG TDI or C2D pin sharing function
9	GNDDetect	Can be used by target system for debugger presence detection.
10	RESET / C2CKps	Target CPU reset or C2CK pin sharing function
12	TRACECLK	ETM trace clock pin
14	TRACED0	Trace data output pin 0
16	TRACED1	Trace data output pin 1
18	TRACED2	Trace data output pin 2
20	TRACED3	Trace data output pin 3
7, 11, 13	NC	Not connected
3, 5, 15, 17, 19	GND	Ground

### 3.7 Simplicity Connector

The Simplicity Connector enables the advanced debugging features, such as the AEM, the virtual COM port, and the Packet Trace Interface, to be used towards an external target. The pinout is illustrated in the figure below.

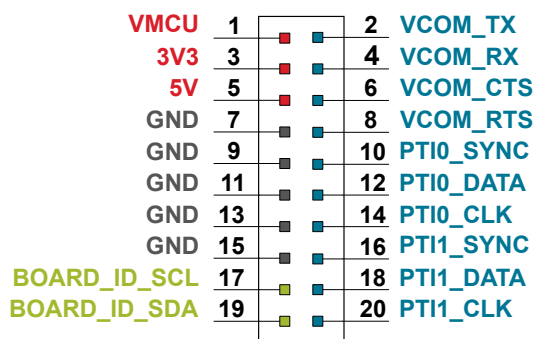

Figure 3.7. Simplicity Connector

**Note:** Current drawn from the VMCU voltage pin is included in the AEM measurements, while the 3V3 and 5V voltage pins are not. When monitoring the current consumption of an external target with the AEM, unplug the radio board from the mainboard to avoid adding the radio board's current consumption to the measurements.

Table 3.4. Simplicity Connector Pin Descriptions

Pin Number(s)	Function	Description
1	VMCU	VMCU power rail, monitored by the AEM
3	3V3	3V3 power rail
5	5V	5V power rail
2	VCOM_TX	Virtual COM Tx
4	VCOM_RX	Virtual COM Rx
6	VCOM_CTS	Virtual COM CTS
8	VCOM_RTS	Virtual COM RTS
10	PTI0_SYNC	Packet Trace 0 Sync
12	PTI0_DATA	Packet Trace 0 Data
14	PTI0_CLK	Packet Trace 0 Clock
16	PTI1_SYNC	Packet Trace 1 Sync
18	PTI1_DATA	Packet Trace 1 Data
20	PTI1_CLK	Packet Trace 1 Clock
17	BOARD_ID_SCL	Board ID SCL
19	BOARD_ID_SDA	Board ID SDA
7, 9, 11, 13, 15	GND	Ground

### 3.8 Mini Simplicity Connector

The Mini Simplicity Connector on the Wireless Pro Kit Mainboard offers advanced debugging features on a 10-pin connector to be used towards an external target. The Mini Simplicity Connector offers the following features:

- Serial Wire Debug (SWD) with SWO
- Packet Trace Interface (PTI)
- Virtual COM port (VCOM)
- AEM monitored voltage rail

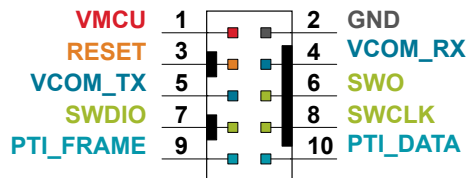

Figure 3.8. Mini Simplicity Connector

**Note:** Current drawn from the VMCU voltage pin is included in the AEM measurements. When monitoring the current consumption of an external target with the AEM, unplug the radio board from the Wireless Pro Kit Mainboard to avoid adding the radio board's current consumption to the measurements.

Table 3.5. Mini Simplicity Connector Pin Descriptions

Pin Number(s)	Function	Description
1	VMCU	Target voltage on the debugged application. Supplied and monitored by the AEM when power selection switch is in the "AEM" position.
2	GND	Ground
3	RESET	Target device reset
4	VCOM_RX	Virtual COM Rx
5	VCOM_TX	Virtual COM Tx
6	SWO	Serial Wire Output
7	SWDIO	Serial Wire Data
8	SWCLK	Serial Wire Clock
9	PTI_FRAME	Packet Trace Frame Signal
10	PTI_DATA	Packet Trace Data Signal

**Note:** Mini Simplicity Connector pin-out is referenced from the device target side. I.e. VCOM\_RX is output from board controller and input to the connected device.

### 3.9 Debug Adapter

The BRD8010A STK/WSTK Debug Adapter is an adapter board which plugs directly into the debug connector and the Simplicity Connector on the mainboard. It combines selected functionality from the two connectors to a smaller footprint 10-pin connector, which is more suitable for space-constrained designs.

For versatility, the debug adapter features three different 10-pin debug connectors:

- Silicon Labs Mini Simplicity Connector
- ARM Cortex 10-pin Debug Connector
- Silicon Labs ISA3 Packet Trace

The ARM Cortex 10-pin Debug Connector follows the standard Cortex pinout defined by ARM and allows the Wireless Pro Kit to be used to debug hardware designs that use this connector.

The ISA3 connector follows the same pinout as the Packet Trace connector found on the Silicon Labs Ember Debug Adapter (ISA3). This enables using the Wireless Pro Kit to debug hardware designs that use this connector.

The Mini Simplicity Connector is designed to offer advanced debug features from the kit on a 10-pin connector. The connector has the same pinout and functionality as described in . It is only necessary to use the debug adapter to get access to the Mini Simplicity Connector when using the Wireless STK Mainboard (BRD4001A). If using the Wireless Pro Kit Mainboard (BRD4002A), use the Mini Simplicity Connector on the mainboard instead.



## 4. Power Supply and Reset

### 4.1 Radio Board Power Selection

The MGM260P on a Wireless Pro Kit can be powered by one of these sources:

- The debug USB cable
- A 3 V coin cell battery
- A USB regulator on the radio board (for devices with USB support only)

The power source for the radio board is selected with the slide switch in the lower left corner of the Wireless STK Mainboard or the Wireless Pro Kit Mainboard. The figure below shows how the different power sources can be selected with the slide switch.

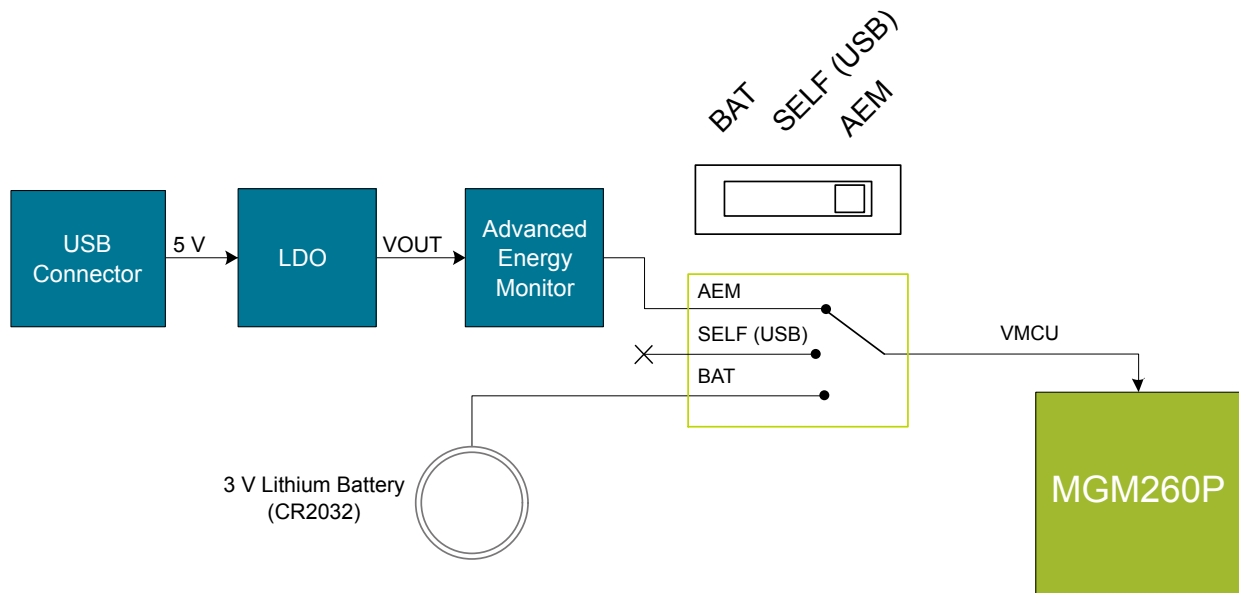

**Figure 4.1. Power Switch**

**Note:** The middle position is denoted by "USB" on the Wireless STK Mainboard, while it is denoted by "SELF" on the Wireless Pro Kit Mainboard. The slide switch functions the same on both mainboards.

**Note:** The AEM can only measure the current consumption of the MGM260P when the power selection switch is in the **AEM** position.

**AEM position:** With the switch in the AEM position, a low noise LDO on the mainboard is used to power the radio board. This LDO is again powered from the debug USB cable. The AEM is now also connected in series, allowing accurate, high-speed current measurements and energy debugging/profiling.

**USB position:** With the switch in the USB position, radio boards with USB-support can be powered by a regulator on the radio board itself. BRD4350A does not contain a USB regulator, and setting the switch in the **USB** position will cause the MGM260P to be unpowered.

**BAT position:** With the switch in the BAT position, a 20 mm coin cell battery in the CR2032 socket can be used to power the device. With the switch in this position, no current measurements are active. This is the switch position that should be used when the radio board is powered with an external power source. The Wireless Pro Kit Mainboard (BRD4002A) features an additional 2-pin JST connector connected in parallel to the CR2032 socket that can be used with an external power source between 1.8 V and 3.6 V instead of a coin cell. The coin cell battery is not protected from reverse current, and it is therefore important to remove the coin cell battery from the CR2032 socket if applying external power.

**Note:** The current sourcing capabilities of a coin cell battery might be too low to supply certain wireless applications.

## 4.2 Kit Power

There are normally two main contributions to the power consumption from the mainboard USB connector, i.e., two main current paths:

- One being monitored by the AEM that goes to the target power domain (VMCU)
- One that goes to the board controller power domain

While the current consumption of the board controller section is fairly deterministic and stable, the current consumption connected to the target's power domain (VMCU) varies widely depending on the application and the slide switch position. Typically, the board controller power domain draws 200 mA on the Wireless Starter Kit Mainboard (BRD4001A) and 250 mA on the Wireless Pro Kit Mainboard (BRD4002A). The mainboards use linear regulators, and the recommended input voltage is 4.4 - 5.25 V. Use a USB host or power supply and cables that can deliver at least the total amount of current required by the kit.

The 5V net exposed on the breakout pads, EXP header, and radio board is also sourced from the mainboard USB connector when the power select switch is in the AEM position. The 3V3 net exposed on the same peripherals is always sourced from the mainboard USB connector. The current consumption of these nets must be included in the total current consumption of the kit if these are utilized.

### 4.2.1 Board Controller Power

The board controller is responsible for important features, such as the debugger and the AEM, and is powered exclusively through the USB port in the top left corner of the board. This part of the kit resides on a separate power domain, so a different power source can be selected for the target device while retaining debugging functionality. This power domain is also isolated to prevent current leakage from the target power domain when power to the board controller is removed.

The board controller power domain is not influenced by the position of the power switch.

The kit has been carefully designed to keep the board controller and the target power domains isolated from each other as one of them powers down. This ensures that the target MGM260P device will continue to operate in the **BAT** mode.

### 4.2.2 AEM Power

The supply for the target power domain (VMCU) is a linear regulator integrated with the AEM described in Section 7. [Advanced Energy Monitor](#) when the power select switch is in the AEM position. The output voltage of the regulator is fixed to 3.3 V on the Wireless STK Mainboard (BRD4001A), while it can be adjusted between 1.8 V and 3.6 V on the Wireless Pro Kit Mainboard (BRD4002A) using the [admin console](#).

The output current on the Wireless Pro Kit Mainboard (BRD4002A) is limited by an overcurrent protection (OCP) function, which depends on the programmed VMCU voltage:  $OCP (A) \approx VMCU_{SET} (V) \times 0.2 (A/V)$ . Approaching or exceeding the OCP limit is not recommended as the output voltage will be pulled low, which causes loss of function.

The maximum recommended output current on the Wireless STK Mainboard (BRD4001A) is 300 mA.

## 4.3 Target Reset

The MGM260P Module can be reset by a few different sources:

- A user pressing the RESET button
- The on-board debugger pulling the RESET pin low
- An external debugger pulling the RESET pin low

In addition to the reset sources mentioned above, a reset to the MGM260P will also be issued during board controller boot-up. This means that removing power to the board controller (unplugging the J-Link USB cable) will not generate a reset but plugging the cable back in will as the board controller boots up.

## 5. Peripherals

The Wireless Pro Kit has a set of peripherals that showcase some of the MGM260P features.

Note that most MGM260P I/Os routed to peripherals are also routed to the breakout pads or the EXP header, which must be taken into consideration when using these I/Os.

### 5.1 Push Buttons and LEDs

The kit has two user push buttons, marked BTN0 and BTN1, and two yellow LEDs, marked LED0 and LED1.

BTN0 and LED0 share the connection to GPIO pin PC07, and BTN1 and LED1 are both connected to PC08.

To use the push buttons as inputs to the MGM260P, each button's GPIO pin must be configured as an input. Configure the pins as outputs to control the LEDs. Note that LEDs are connected to GPIO pins in an active-low configuration.

The push buttons are debounced by RC filters with a time constant of 1 ms.

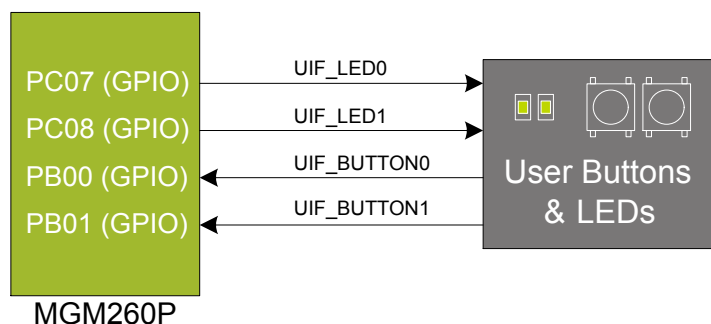

Figure 5.1. Buttons/LEDs

### 5.2 Joystick

The kit has an analog joystick connected to the MGM260P on pin when using a Wireless Pro Kit Mainboard (BRD4002A). The Wireless STK Mainboard (BRD4001A) does not feature a joystick. Moving the joystick around connects different pull-down resistors to the joystick output, which together with the pull-up resistor on VMCU, creates different output voltages,  $V_o$ , that can be read using the ADC on the MGM260P.

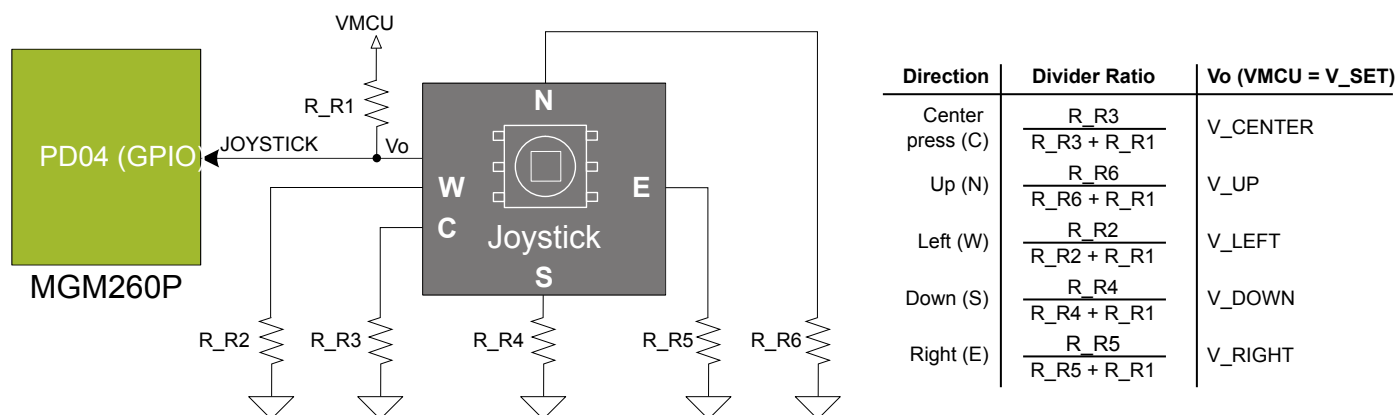

Figure 5.2. Joystick

### 5.3 Memory LCD-TFT Display

A 1.28-inch SHARP Memory LCD-TFT is available on the kit to enable interactive applications to be developed. The display has a high resolution of 128 x 128 pixels and consumes very little power. It is a reflective monochrome display, so each pixel can only be light or dark, and no backlight is needed in normal daylight conditions. Data sent to the display is stored in the pixels on the glass, which means no continuous refreshing is required to maintain a static image.

The display interface consists of a SPI-compatible serial interface and some extra control signals. Pixels are not individually addressable, instead data is sent to the display one line (128 bits) at a time.

The Memory LCD-TFT display is shared with the kit's board controller, allowing the board controller application to display useful information when the user application is not using the display. The user application always controls ownership of the display with the DISP\_ENABLE signal:

- DISP\_ENABLE = LOW: The board controller has control of the display
- DISP\_ENABLE = HIGH: The user application (MGM260P) has control of the display

Power to the display is sourced from the target application power domain when the MGM260P controls the display and from the board controller's power domain when the DISP\_ENABLE line is low. Data is clocked in on DISP\_SI when DISP\_CS is high, and the clock is sent on DISP\_SCLK. The maximum supported clock speed is 1.1 MHz.

DISP\_EXTCOMIN is the "COM Inversion" line. It must be pulsed periodically to prevent static build-up in the display itself. Refer to the LS013B7DH03 documentation for more information on driving the display.

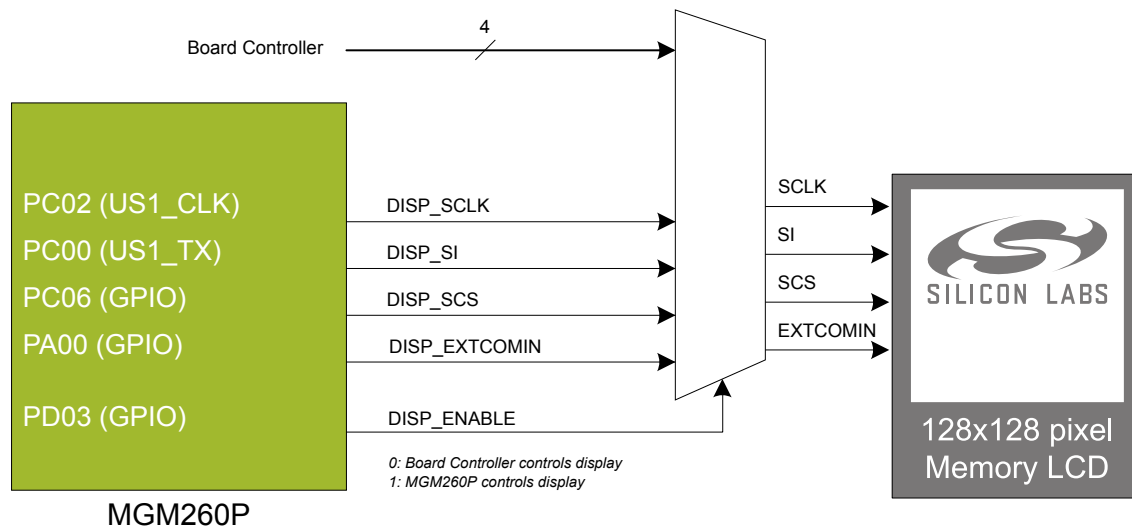

Figure 5.3. 128x128 Pixel Memory LCD

### 5.4 Si7021 Relative Humidity and Temperature Sensor

The Si7021 I<sup>2</sup>C relative humidity and temperature sensor is a monolithic CMOS IC integrating humidity and temperature sensor elements, an analog-to-digital converter, signal processing, calibration data, and an I<sup>2</sup>C Interface. The patented use of industry-standard, low-K polymeric dielectrics for sensing humidity enables the construction of low-power, monolithic CMOS Sensor ICs with low drift and hysteresis and excellent long term stability.

The humidity and temperature sensors are factory-calibrated and the calibration data is stored in the on-chip non-volatile memory. This ensures that the sensors are fully interchangeable with no recalibration or software changes required.

The Si7021 is available in a 3x3 mm DFN package and is reflow solderable. It can be used as a hardware and software-compatible drop-in upgrade for existing RH/temperature sensors in 3x3 mm DFN-6 packages, featuring precision sensing over a wider range and lower power consumption. The optional factory-installed cover offers a low-profile, convenient means of protecting the sensor during assembly (e.g., reflow soldering) and throughout the life of the product, excluding liquids (hydrophobic/oleophobic) and particulates.

The Si7021 offers an accurate, low-power, factory-calibrated digital solution ideal for measuring humidity, dew point, and temperature in applications ranging from HVAC/R and asset tracking to industrial and consumer platforms.

The I<sup>2</sup>C bus used for the Si7021 is shared with the EXP header. The temperature sensor is normally isolated from the I<sup>2</sup>C line. To use the sensor, SENSOR\_ENABLE must be set high. When enabled, the sensor's current consumption is included in the AEM measurements.

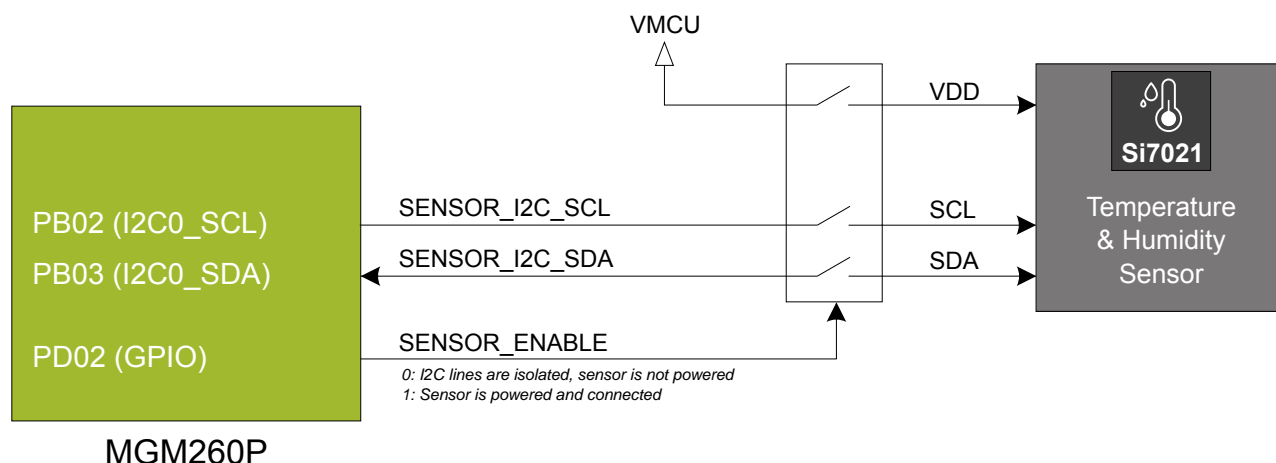

Figure 5.4. Si7021 Relative Humidity and Temperature Sensor

Refer to the Silicon Labs web pages for more information: <http://www.silabs.com/humidity-sensors>.

## 5.5 Virtual COM Port

An asynchronous serial connection to the board controller is provided for application data transfer between a host PC and the target MGM260P. This eliminates the need for an external serial port adapter.

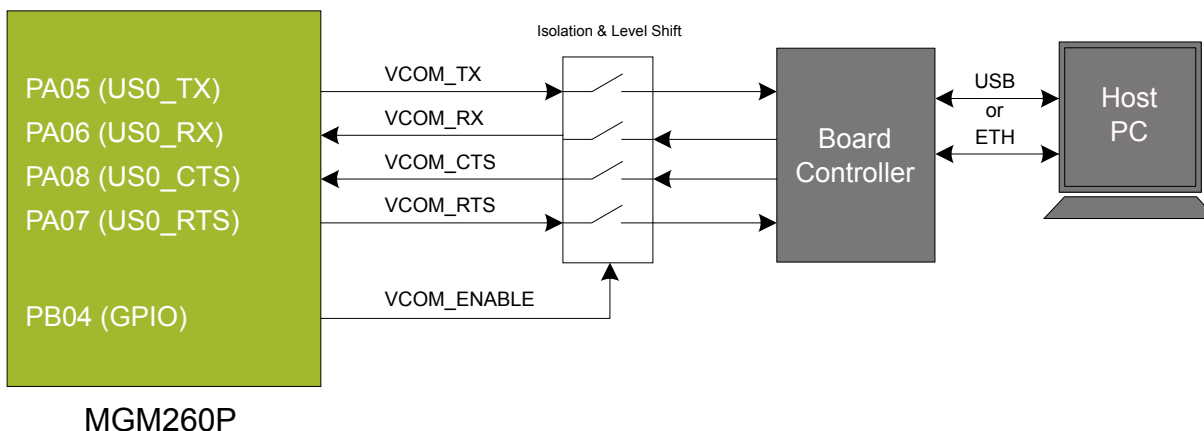

Figure 5.5. Virtual COM Port Interface

The virtual COM port consists of a physical UART between the target device and the board controller and a logical function in the board controller that makes the serial port available to the host PC over USB or Ethernet. The UART interface consists of four pins and an enable signal.

Table 5.1. Virtual COM Port Interface Pins

Signal	Description
VCOM_TX	Transmit data from the MGM260P to the board controller
VCOM_RX	Receive data from the board controller to the MGM260P
VCOM_CTS	Clear to Send hardware flow control input, asserted by the board controller when it is ready to receive more data
VCOM_RTS	Request to Send hardware flow control output, asserted by the MGM260P when it is ready to receive more data
VCOM_ENABLE	Enables the VCOM interface, allowing data to pass through to the board controller

The parameters of the serial port, such as baud rate or flow control, can be configured using the [admin console](#). The default settings depend on which radio board is used with the mainboard.

**Note:** The VCOM port is only available when the board controller is powered, which requires the J-Link USB cable to be inserted.

**Note:** There may be slight differences on the terminal prompt and settings between the Wireless Starter Kit Mainboard and the Wireless Pro Kit Mainboard.

### 5.5.1 Host Interfaces

Data can be exchanged between the board controller and the target device through the VCOM interface, which is then available to the user in two different ways:

- Virtual COM port using a standard USB-CDC driver
- TCP/IP by connecting to the Wireless STK on TCP/IP port 4901 with a Telnet client

When connecting via USB, the device should automatically show up as a COM port. The actual device name that is associated with the kit depends on the operating system and how many devices are or have been connected previously. The following are examples of what the device might show up as:

- JLink CDC UART Port (COM5) on Windows hosts
- /dev/cu.usbmodem1411 on macOS
- /dev/ttyACM0 on Linux

Data sent by the target device into the VCOM interface can be read from the COM port, and data written to the port is transmitted to the target device. Connecting to the Wireless STK on port 4901 gives access to the same data over TCP/IP. Data written into the VCOM interface by the target device can be read from the socket, and data written into the socket is transmitted to the target device.

**Note:** Only one of these interfaces can be used at the same time, with the TCP/IP socket taking priority. This means that if a socket is connected to port 4901, no data can be sent or received on the USB COM port.

### 5.5.2 Serial Configuration

By default, the VCOM serial port is configured to use 115200 8N1 (115.2 kbit/s, 8 data bits, 1 stop bit) with flow control disabled/ignored. The configuration can be changed using the admin console:

```
WPK> serial vcom config  
Usage: serial vcom config [--nostore] [handshake <rts/cts/rtscts/disable/auto>] [speed <9600,921600>]
```

Using this command, the baud rate can be configured between 9600 and 921600 bit/s, and hardware handshake can be enabled or disabled on either or both flow control pins.

### 5.5.3 Hardware Handshake

The VCOM peripheral supports basic RTS/CTS flow control.

VCOM\_CTS (target clear to send) is a signal that is output from the board controller and input to the target device. The board controller de-asserts this pin whenever its input buffer is full and it is unable to accept more data from the target device. If hardware handshake is enabled in the target firmware, its UART peripheral will halt when data is not being consumed by the host. This implements end-to-end flow control for data moving from the target device to the host.

VCOM\_CTS is connected to the RTS pin on the board controller and is enabled by setting handshake to either RTS or RTSCTS using the "serial vcom config" command.

VCOM\_RTS (target request to send) is a signal that is output from the target device and input to the board controller. The board controller will halt transmission of data towards the target if the target device de-asserts this signal. This gives the target firmware a means to hold off incoming data until it can be processed. Note that de-asserting RTS will not abort the byte currently being transmitted, so the target firmware must be able to accept at least one more character after RTS is de-asserted.

VCOM\_RTS is connected to the CTS pin of the board controller. It is enabled by setting handshake to either CTS or RTSCTS using the "serial vcom config" command in the admin console. If CTS flow control is disabled, the state of VCOM\_RTS will be ignored and data will be transmitted to the target device anyway.

**Table 5.2. Hardware Handshake Configuration**

Mode	Description
disabled	RTS (VCOM_CTS) is not driven by the board controller and CTS (VCOM_RTS) is ignored.
rts	RTS (VCOM_CTS) is driven by the board controller to halt target from transmitting when input buffer is full. CTS (VCOM_RTS) is ignored.
cts	RTS (VCOM_CTS) is not driven by the board controller. Data is transmitted to the target device if CTS (VCOM_RTS) is asserted and halted when de-asserted.
rtscts	RTS (VCOM_CTS) is driven by the board controller to halt target when buffers are full. Data is transmitted to the target device if CTS (VCOM_RTS) is asserted and halted when de-asserted.

**Note:** Enabling CTS flow control without configuring the VCOM\_RTS pin can result in no data being transmitted from the host to the target device.



## 6. Board Controller

### 6.1 Introduction

The Wireless STK Mainboard and the Wireless Pro Kit Mainboard contain a dedicated microcontroller for some of the advanced kit features provided. This microcontroller is referred to as the board controller and is not programmable by the user. The board controller acts as an interface between the host PC and the target device on the radio board, as well as handling some housekeeping functions on the board.

**Note:** This chapter describes the board controller on both the Wireless Starter Kit Mainboard and the Wireless Pro Kit Mainboard. There might be slight differences between these two boards, such as the exact menu and format on the admin console, not highlighted in this chapter. The logic analyzer is furthermore only available on BRD4002A.

Some of the kit features actively managed by the board controller are:

- The [on-board debugger](#), which can flash and debug both on-board and external targets.
- The [Advanced Energy Monitor](#), which provides real-time energy profiling of the user application.
- The Packet Trace Interface, which is used in conjunction with PC software to provide detailed insight into an active radio network.
- The [logic analyzer](#), which can capture digital signals time-synchronized to the energy profiling and packet trace data.
- The [Virtual COM Port](#) and [Virtual UART](#) interfaces, which provide ways to transfer application data between the host PC and the target processor.
- The [admin console](#), which provides configuration of the various board features.

Silicon Labs publishes updates to the board controller firmware in the form of firmware upgrade packages. These updates may enable new features or fix issues. See [Section 9.1 Firmware Upgrades](#) for details on firmware upgrade.

### 6.2 Admin Console

The admin console is a command line interface to the board controller on the kit. It provides functionality for configuring the kit behavior and retrieving configuration and operational parameters.

#### 6.2.1 Connecting

The admin console is available when the Wireless Pro Kit is connected to Ethernet using the Ethernet connector in the top left corner of the mainboard. See [Section 8.1.2 Ethernet Interface](#) for details on the Ethernet connectivity.

Connect to the admin console by opening a telnet connection to the kit's IP address, port number 4902.

When successfully connected, a `WPK>` prompt is displayed.

## 6.2.2 Built-in Help

The admin console has a built-in help system which is accessed by the `help` command. The `help` command will print a list of all top level commands:

```
WPK> help
***** Root commands *****
aem          AEM Configuration and Information Commands [ avg, calibrate, calinfo ]
boardid      Commands for board ID probe. [ list, probe ]
dbg          Debug interface status and control [ info, mode ]
dch          Datachannel control and info commands [ info, message ]
discovery    Discovery service commands. [ key ]
net          Network commands. [ dnslookup, ip, mac ]
pti          Packet trace interface status and control [ config, disable, dump, ... ]
quit        Exit from shell
serial       Serial channel commands [ vcom ]
sys          System commands [ crashlog, nickname, reset, ... ]
target       Target commands. [ button, go, halt, ... ]
time         Time Sync Service commands [ client, disable, info, ... ]
user         User management functions [ login, ]
```

The `help` command can be used in conjunction with any top level command to get a list of sub-commands with descriptions. For example, `pti help` will print a list of all available sub-commands of `pti`:

```
WPK> pti help
***** pti commands *****
config       Configure packet trace
disable      Disable packet trace
dump         Dump PTI packets to the console as they come
enable       Enable packet trace
info         Packet trace state information
```

This means that running `pti enable` will enable packet trace.

## 6.2.3 Command Examples

### PTI Configuration

```
pti config 0 efruart 1600000
```

Configures PTI to use the "EFRUART" mode at 1.6 Mb/s.

### Serial Port Configuration

```
serial config vcom handshake enable
```

Enables hardware handshake on the VCOM UART connection.

## 6.3 Virtual UART

The Virtual UART (VUART) interface provides a high-performance application data interface that does not require additional I/O pins apart from the debug interface.

The Wireless STK makes the VUART interface available on TCP/IP port 4900.

### 6.3.1 Target-to-Host

Target-to-host communication utilizes the SWO-pin of the debug interface through the ITM debug peripheral. This approach allows a sleepy target device to enter all energy modes and still wake up intermittently to send debug information. The baud rate of the SWO data is locked to 875 kHz.

VUART utilizes ITM stimulus port 0 for general purpose printing. Silicon Labs' networking stacks utilize ITM stimulus port 8 for debug printing. The data on port 8 is encapsulated in additional framing and will also appear in the Simplicity Studio Network Analyzer.

### 6.3.2 Host-to-Target

Host-to-target communication utilizes SEGGER's Real Time Transfer (RTT) technology. A full explanation of how this works can be found in *J-Link/J-Trace User Guide (UM08001)*. Briefly summarized, RTT consists of a structure called the RTT Control Block, which is located in RAM. This control block points to circular buffers that the debugger can write data into. The target application can then read data out of this circular buffer.

The board controller will start searching for the RTT Control Block upon receiving data on TCP/IP port 4900. If the board controller is unable to locate the RTT Control Block, it will return an error message on the same connection. For the board controller to be able to locate the RTT Control Block, it has to be aligned on a 1024-byte boundary in RAM.

After initializing the RTT connection, the target will only enter emulated EM2 and EM3 where the power consumption remains similar to EM1. This is because RTT utilizes the debug interface, which requires use of high-frequency oscillators. Energy modes EM4S and EM4H will work as normal. When debugging energy consumption, it is therefore important to not send data on TCP/IP port 4900 as not to instantiate the RTT connection.

### 6.3.3 Limitations

- Because the SWO-connection can be disabled by the debugger at will, it is important for the target application to verify that SWO is enabled and configured before each transmission on the interface.
- After initializing host-to-target communication over RTT by sending data on TCP/IP port 4900, the target application will be unable to enter EM2 and EM3. This is because RTT utilizes the debug connection of the target.
- VUART might not work reliably during an active debugging session. This is because there is contention over the target's debug interface. The board controller will defer accessing the target until it is made available by the host debugger.
- VUART is designed with the assumption that only the board controller will access the RTT control block. If the target application uses RTT for other purposes, such as Segger SystemView, refrain from using VUART.

### 6.3.4 Troubleshooting

Problem	Solution
No data received after ending a debug session.	After certain debugger operations, the host computer manually disables SWO on the target to conserve power. This might cause SWO data to not appear if the target application initialized SWO before the debugger has disconnected. Either press the RESET button on the Wireless Starter Kit to reset the target application or make sure that the target application verifies that SWO is enabled and configured before sending any data.
No data received after flashing a new application.	
Other issues	Disconnect from TCP port 4900, press the RESET button on the kit, then reconnect to 4900. If this does not fix the issue, try to restart the kit by unplugging and replugging the USB cable.

## 7. Advanced Energy Monitor

### 7.1 Introduction

Any embedded developer seeking to make their embedded code spend as little energy as the underlying architecture supports needs tools to easily and quickly discover inefficiencies in the running application. This is what the Simplicity Energy Profiler is designed to do. In real-time, the Energy Profiler will graph and log current as a function of time while correlating this to the actual target application code running on the MGM260P. There are multiple features in the profiler software that allow for easy analysis, such as markers and statistics on selected regions of the current graph or aggregate energy usage by different parts of the application. The Energy Profiler is available through Simplicity Studio.

### 7.2 Code Correlation

By using the Energy Profiler, current consumption and voltage can be measured and linked to the actual code running on the MGM260P in real-time. The Energy Profiler gets its data from the board controller on the mainboard through the Advanced Energy Monitor (AEM). The current signal is combined with the target processor's Program Counter (PC) sampling by utilizing a feature of the ARM CoreSight debug architecture. The Instrumentation Trace Macrocell (ITM) block can be programmed to sample the MCU's PC at periodic intervals and output these over SWO pin ARM devices. When these two data streams are fused and correlated with the running application's memory map, an accurate statistical profile can be built that shows the energy profile of the running application in real-time.

### 7.3 AEM Circuit

The AEM circuit on the Wireless Pro Kit Mainboard (BRD4002A) and the Wireless STK Mainboard (BRD4001A) measures the current through a sense resistor inside the feedback loop of a low-dropout regulator (LDO). The output voltage of this LDO powers the MGM260P when the power slide switch is in the AEM position. AEM usage on both mainboards is similar, but the implementation and performance on the Wireless Pro Kit Mainboard (BRD4002A) has some key differences, including the utilization of two sense resistors instead of one, and a different LDO, which is explained in Section 7.3.1 AEM Details. The AEM implementation on the Wireless Pro Kit Mainboard (BRD4002A) is shown in the figure below.

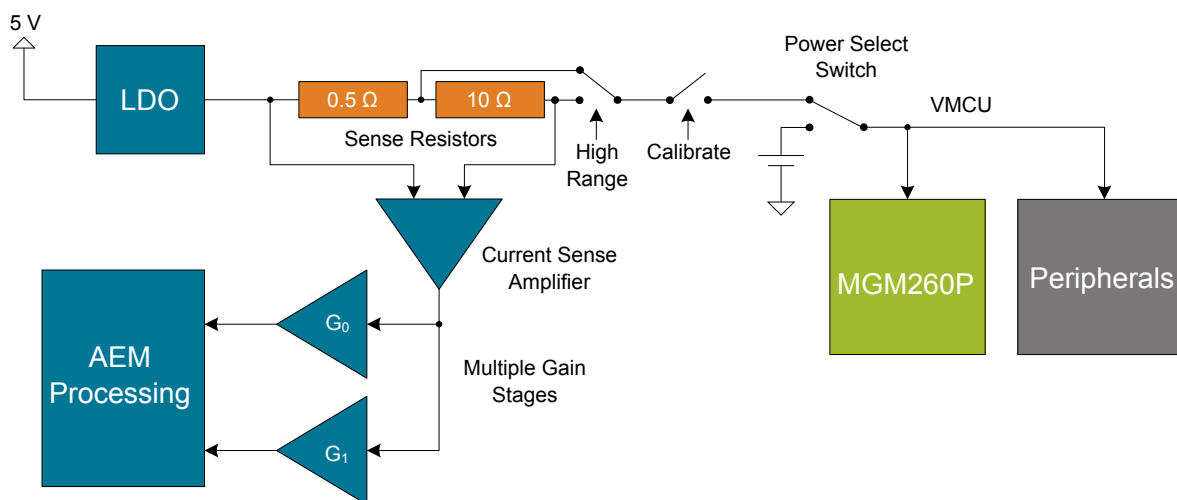

Figure 7.1. Advanced Energy Monitor On The Wireless Pro Kit Mainboard (BRD4002A)

**Note:** The VMCU regulator feedback point is after the sense resistor to ensure that the VMCU voltage is kept constant when the output current changes. Series resistances in the current path will, however, cause some IR drop on VMCU.

**Note:** The AEM circuit only works when the kit is powered and the power switch is in the AEM position.

### 7.3.1 AEM Details

The main differences between the AEM on the Wireless Pro Kit Mainboard (BRD4002A) and the Wireless STK Mainboard (BRD4001A) is summarized in the table below with more in-depth information given in the text to follow.

**Table 7.1. Advanced Energy Monitor Parameters**

Parameter	BRD4002A	BRD4001A
Voltage	1.8 - 3.6 V	3.3 V
Sample Rate	100 kHz	10 kHz
Sense Resistor	10.5 $\Omega$ / 0.5 $\Omega$	2.35 $\Omega$
Measurement Range <sup>1</sup>	0 - 495 mA	0 - 95 mA
<b>Note:</b>		
1. The current sourcing capabilities of the LDO may be different than the measurement range.		

#### Wireless Pro Kit Mainboard (BRD4002A) AEM Design Details

The AEM circuitry on the Wireless Pro Kit Mainboard is capable of measuring current signals in the range of approximately 0.1  $\mu$ A to 495 mA. This is accomplished through a combination of a highly capable current sense amplifier, multiple sense resistors and gain stages, and signal processing within the kit's board controller before the current sense signal is read by a host computer with 100 kHz sample rate for display and/or storage. Averaging on the output data may be required to achieve sufficient accuracy in some situations, such as low currents, which can be traded for lower bandwidth. High current applications require that the regulator is able to supply enough current as described in Section 4.2 Kit Power.

At low currents the current sense amplifier measures the voltage drop over a 10.5  $\Omega$  resistive path. The gain stage further amplifies this voltage with two different parallel gain settings to obtain two current ranges. The transition between these two ranges occurs around 150  $\mu$ A. When the current exceeds a threshold, which is typically between 10 and 30 mA, the AEM circuitry switches from the 10.5  $\Omega$  resistive path to a 0.5  $\Omega$  sense resistor and is now capable of measuring currents up to approximately 495 mA. Should the current drop below the threshold again, the sense resistor is changed back to the 10.5  $\Omega$  resistive path and the AEM is back to using two different gain stages depending on whether the current is above or below 150  $\mu$ A.

The expected typical accuracy of the AEM on the Wireless Pro Kit Mainboard is within 1 %, except for currents in the low tens of microamps where offset errors start to dominate. In this low current region, the expected typical accuracy is some hundred nanoamps. At kit power-up or on a power-cycle, an automatic AEM calibration is performed which compensates for offset errors in the current sense amplifiers. To achieve the stated accuracy, averaging of the AEM output data is required in certain situations (typically at low currents and close to the bottom of the measurement ranges) to reduce noise. Averaging can be applied in Energy Profiler to suit different requirements during or after the acquisition. The analog bandwidth of the measurement circuit depends on multiple factors, such as output current and capacitance on the VMCU net, and may be lower than the output data rate. Generally, higher output current and lower capacitance on VMCU gives a higher analog bandwidth.

#### Wireless STK Mainboard (BRD4001A) AEM Design Details

The AEM circuitry on the Wireless STK Mainboard works conceptually in a similar way to the implementation on the Wireless Pro Kit Mainboard except for two key differences: it uses only one 2.35  $\Omega$  sense resistor and the low-dropout regulator (LDO) is different. For details about the two implementations, the reader is encouraged to see the schematics.

The AEM on the Wireless STK Mainboard is capable of measuring currents in the range of 0.1  $\mu$ A to 95 mA. The second stage amplifier amplifies the signal with two different gain settings with the transition occurring around 250  $\mu$ A. For currents above 250  $\mu$ A, the AEM is accurate within 0.1 mA. When measuring currents below 250  $\mu$ A, the accuracy increases to 1  $\mu$ A. Even though the absolute accuracy is 1  $\mu$ A in the sub 250  $\mu$ A range, the AEM can detect changes in the current consumption as small as 0.1  $\mu$ A. It is possible to source currents above the measurement range as described in Section 4.2 Kit Power. The board controller outputs the AEM data with 10 kHz sample rate.

## 8. On-Board Debugger

The Wireless Pro Kit Mainboard and the Wireless STK Mainboard contain an integrated debugger, which can be used to download code and debug the MGM260P. In addition to programming a target on a plug-in radio board, the debugger can also be used to program and debug external Silicon Labs EFM32, EFM8, EZR32, and EFR32 devices connected through the debug connector.

The debugger supports three different debug interfaces for Silicon Labs devices:

- Serial Wire Debug is supported by all EFM32, EFR32, and EZR32 devices
- JTAG is supported by EFR32 and some EFM32 devices
- C2 Debug is supported by EFM8 devices

For debugging to work properly, make sure the selected debug interface is supported by the target device. The debug connector on the board supports all three of these modes.

### 8.1 Host Interfaces

The Wireless Pro Kit supports connecting to the on-board debugger using either Ethernet or USB.

Many tools support connecting to a debugger using either USB or Ethernet. When connected over USB, the kit is identified by its J-Link serial number. When connected over Ethernet, the kit is normally identified by its IP address. Some tools also support using the serial number when connecting over Ethernet; however, this typically requires the computer and the kit to be on the same subnet for the discovery protocol (using UDP broadcast packets) to work.

#### 8.1.1 USB Interface

The USB interface is available whenever the USB connector on the left-hand side of the mainboard is connected to a computer.

#### 8.1.2 Ethernet Interface

The Ethernet interface is available when the mainboard Ethernet connector in the top left corner is connected to a network. Normally, the kit will receive an IP address from a local DHCP server, and the IP address is printed on the LCD display. If your network does not have a DHCP server, you need to connect to the kit via USB and set the IP address manually using Simplicity Studio, Simplicity Commander, or J-Link Configurator.

For the Ethernet connectivity to work, the kit must still be powered through the mainboard USB connector.

#### 8.1.3 Serial Number Identification

All Silicon Labs kits have a unique J-Link serial number which identifies the kit to PC applications. This number is 9 digits and is normally on the form 44xxxxxxxx.

The J-Link serial number is normally printed at the bottom of the kit LCD display.

## 8.2 Debug Modes

The kit can be used in various debug modes as explained in this chapter. The on-board debugger can be used to debug the MGM260P on the radio board, or it can be used to debug a supported external target board using either the debug connector or the Mini Simplicity Connector. An external debugger can furthermore be used to debug the MGM260P on the radio board using the debug connector. Selecting the active debug mode is done in Simplicity Studio.

**Note:** The Wireless Starter Kit Mainboard (BRD4001A) does not feature a Mini Simplicity Connector; therefore, debugging an external target board directly over the Mini Simplicity Connector is not supported on this mainboard. However, it is possible to debug an external target that uses a Mini Simplicity Connector from the Wireless Starter Kit Mainboard by using a BRD8010A STK/WSTK Debug Adapter.

**Debug MCU:** In this mode, the on-board debugger is connected to the MGM260P on the kit. To use this mode, set the debug mode to [MCU].

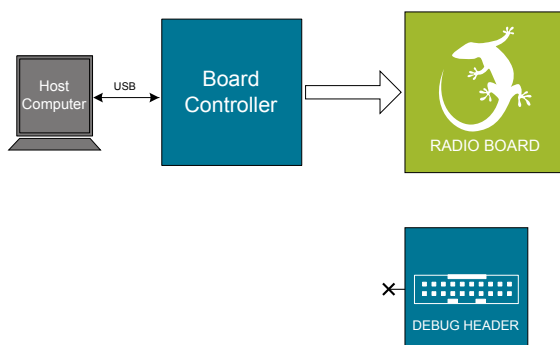

**Figure 8.1. Debug MCU**

**Debug OUT:** In this mode, the on-board debugger can be used to debug a supported Silicon Labs device mounted on a custom board using the debug connector. To use this mode, set the debug mode to [Out].

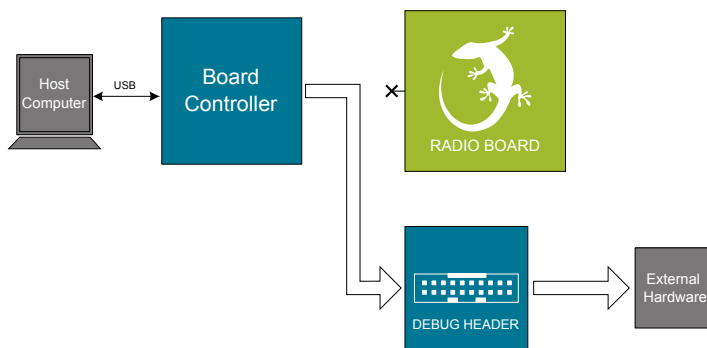

**Figure 8.2. Debug OUT**

**Debug IN:** In this mode, the on-board debugger is disconnected and an external debugger can be used to debug the MGM260P on the kit over the debug connector. To use this mode, set the debug mode to [In].

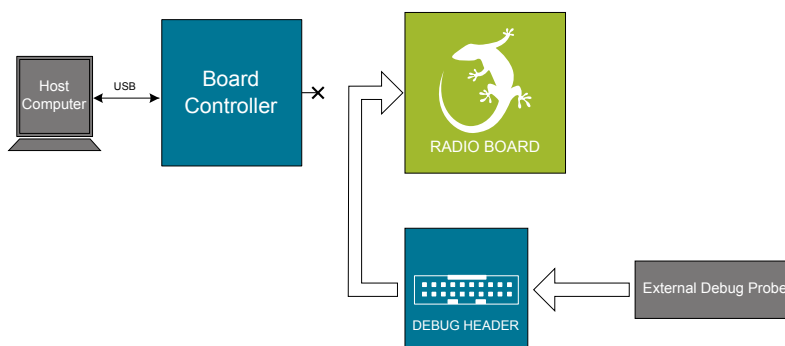

**Figure 8.3. Debug IN**

**Note:** For "Debug IN" to work, the kit board controller must be powered through the Debug USB connector.

**Debug MINI:** The Wireless Pro Kit mainboard features a dedicated Mini Simplicity Connector on the board. In this mode, the on-board debugger can be used to debug a supported Silicon Labs device mounted on a custom board over Serial Wire Debug. Virtual COM port and Packet Trace Interface is also available in this mode. To use this mode, set the debug mode to **[Mini]**.

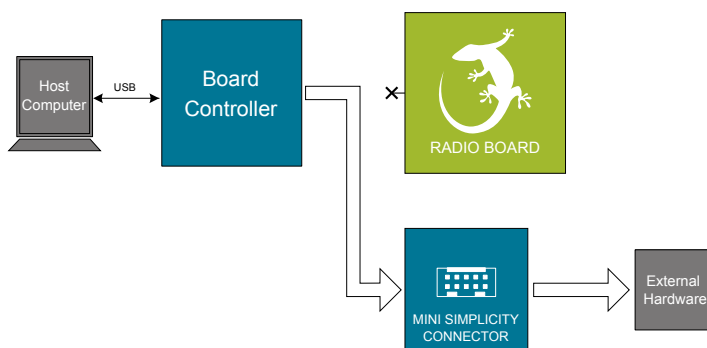

**Figure 8.4. Mini Out**

Depending on the position of the mainboard power switch and the presence of a coin battery (or external power source on the battery connector of BRD4002A), the Wireless Pro Kit can supply voltage on the VMCU rail available on the Simplicity Connector and the Mini Simplicity Connector. Careful consideration must be taken to avoid any power conflicts with the external hardware. For more information regarding debugging external hardware see [AN958: Debugging and Programming Interfaces for Custom Designs](#).

### 8.3 Debugging During Battery Operation

When the MGM260P is battery-powered and the J-Link USB is still connected, the on-board debug functionality is available. If the USB power is disconnected, the Debug IN mode will stop working.

If debug access is required when the target is running off another energy source, such as a battery, and the board controller is powered down, make direct connections to the GPIOs used for debugging, which are exposed on the breakout pads.



## 9. Kit Configuration and Upgrades

The kit configuration dialog in Simplicity Studio allows you to change the J-Link adapter debug mode, upgrade its firmware, and change other configuration settings. To download Simplicity Studio, go to [silabs.com/simplicity](http://silabs.com/simplicity).

In the main window of the Simplicity Studio's Launcher perspective, the debug mode and firmware version of the selected J-Link adapter are shown. Click the [**Change**] link next to any of these settings to open the kit configuration dialog.

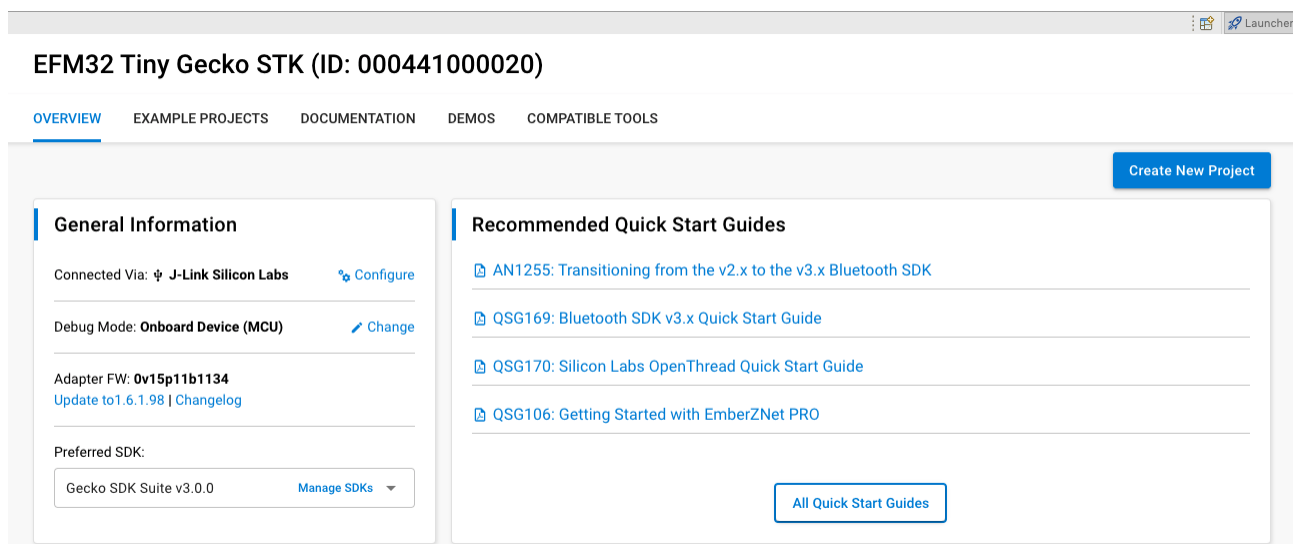

**Figure 9.1. Simplicity Studio Kit Information**

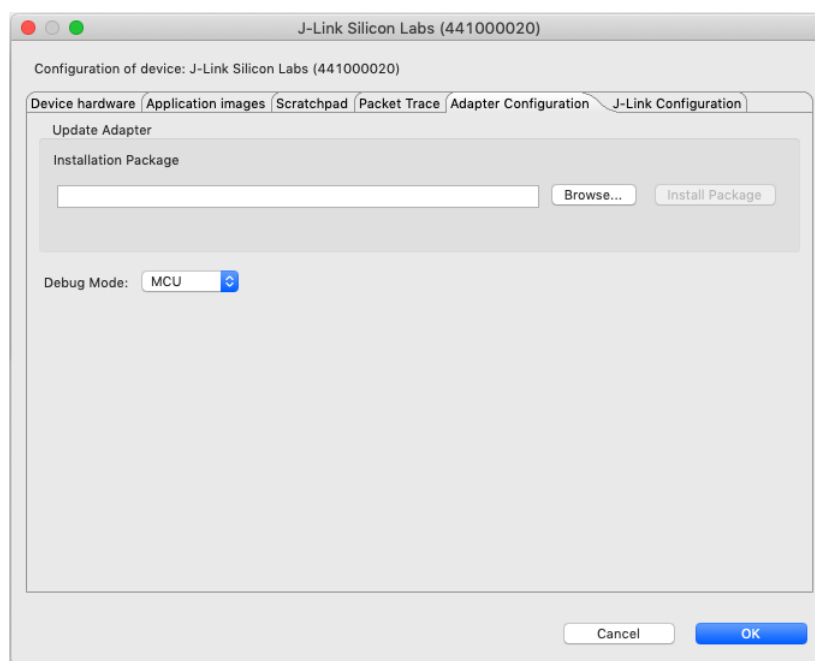

**Figure 9.2. Kit Configuration Dialog**

### 9.1 Firmware Upgrades

You can upgrade the kit firmware through Simplicity Studio. Simplicity Studio will automatically check for new updates on startup.

Detailed instructions to upgrade the SiWx91x Connectivity Firmware can be found on the Silicon Labs web pages: .

## 10. Schematics, Assembly Drawings, and BOM

Schematics, assembly drawings, and Bill of Materials (BOM) are available through Simplicity Studio when the kit documentation package has been installed. They are also available from the kit page on the Silicon Labs website: [silabs.com](https://silabs.com).

## 11. Kit Revision History

The kit revision can be found printed on the kit packaging label, as outlined in the figure below. The revision history given in this section may not list every kit revision. Revisions with minor changes may be omitted.

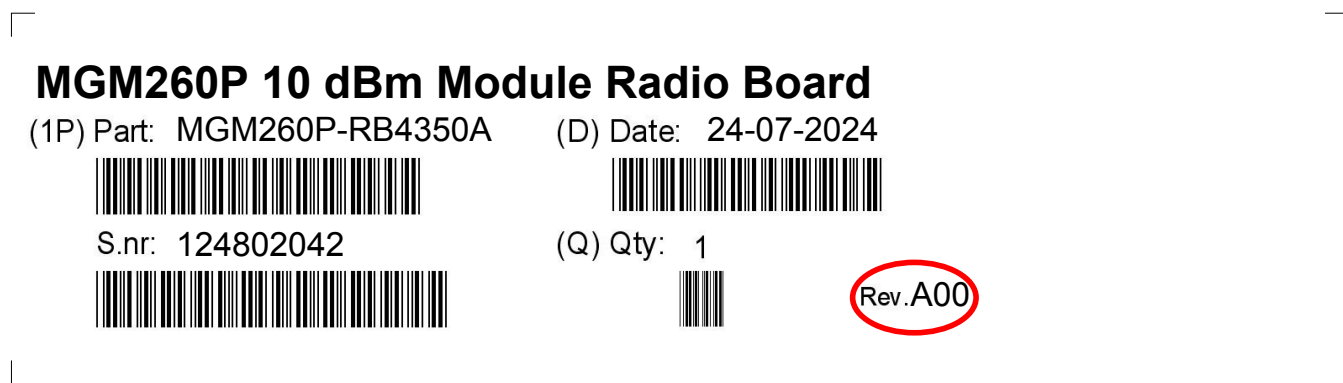

Figure 11.1. Kit Label

### 11.1 MGM260P-RB4350A Revision History

Kit Revision	Released	Description
A00	23 July 2024	Initial kit release with BRD4350A Rev. A03.

## 12. Document Revision History

### Revision 1.0

October 2024

- Initial document release.

# Simplicity Studio

One-click access to MCU and wireless tools, documentation, software, source code libraries & more. Available for Windows, Mac and Linux!



**IoT Portfolio**  
[www.silabs.com/IoT](http://www.silabs.com/IoT)



**SW/HW**  
[www.silabs.com/simplicity](http://www.silabs.com/simplicity)



**Quality**  
[www.silabs.com/quality](http://www.silabs.com/quality)



**Support & Community**  
[www.silabs.com/community](http://www.silabs.com/community)

## Disclaimer

Silicon Labs intends to provide customers with the latest, accurate, and in-depth documentation of all peripherals and modules available for system and software implementers using or intending to use the Silicon Labs products. Characterization data, available modules and peripherals, memory sizes and memory addresses refer to each specific device, and "Typical" parameters provided can and do vary in different applications. Application examples described herein are for illustrative purposes only. Silicon Labs reserves the right to make changes without further notice to the product information, specifications, and descriptions herein, and does not give warranties as to the accuracy or completeness of the included information. Without prior notification, Silicon Labs may update product firmware during the manufacturing process for security or reliability reasons. Such changes will not alter the specifications or the performance of the product. Silicon Labs shall have no liability for the consequences of use of the information supplied in this document. This document does not imply or expressly grant any license to design or fabricate any integrated circuits. The products are not designed or authorized to be used within any FDA Class III devices, applications for which FDA premarket approval is required or Life Support Systems without the specific written consent of Silicon Labs. A "Life Support System" is any product or system intended to support or sustain life and/or health, which, if it fails, can be reasonably expected to result in significant personal injury or death. Silicon Labs products are not designed or authorized for military applications. Silicon Labs products shall under no circumstances be used in weapons of mass destruction including (but not limited to) nuclear, biological or chemical weapons, or missiles capable of delivering such weapons. Silicon Labs disclaims all express and implied warranties and shall not be responsible or liable for any injuries or damages related to use of a Silicon Labs product in such unauthorized applications.

## Trademark Information

Silicon Laboratories Inc.<sup>®</sup>, Silicon Laboratories<sup>®</sup>, Silicon Labs<sup>®</sup>, SiLabs<sup>®</sup> and the Silicon Labs logo<sup>®</sup>, Bluegiga<sup>®</sup>, Bluegiga Logo<sup>®</sup>, EFM<sup>®</sup>, EFM32<sup>®</sup>, EFR, Ember<sup>®</sup>, Energy Micro, Energy Micro logo and combinations thereof, "the world's most energy friendly microcontrollers", Redpine Signals<sup>®</sup>, WiSeConnect, n-Link, EZLink<sup>®</sup>, EZRadio<sup>®</sup>, EZRadioPRO<sup>®</sup>, Gecko<sup>®</sup>, Gecko OS, Gecko OS Studio, Precision32<sup>®</sup>, Simplicity Studio<sup>®</sup>, Telegesis, the Telegesis Logo<sup>®</sup>, USBXpress<sup>®</sup>, Zentri, the Zentri logo and Zentri DMS, Z-Wave<sup>®</sup>, and others are trademarks or registered trademarks of Silicon Labs. ARM, CORTEX, Cortex-M3 and THUMB are trademarks or registered trademarks of ARM Holdings. Keil is a registered trademark of ARM Limited. Wi-Fi is a registered trademark of the Wi-Fi Alliance. All other products or brand names mentioned herein are trademarks of their respective holders.



Silicon Laboratories Inc.  
400 West Cesar Chavez  
Austin, TX 78701  
USA

[www.silabs.com](http://www.silabs.com)